



Company: ANGI Energy  
 Quote:  
 Case 1:

### Ariel Performance

Customer: Apache Corporation  
 Inquiry:  
 Project: Canadian, TX



#### Compressor Data:

Elevation,ft:	2500.00	Barmtr,psia:	13.400	Ambient,°F:	105.00
Frame:	JGQ/2	Stroke, in:	3.00	Rod Dia, in:	1.125
Max RL Tot, lbf:	20000	Max RL Tens, lbf:	10000	Max RL Comp, lbf:	11000
Rated RPM:	1800	Rated BHP:	280.0	Rated PS FPM:	900.0
Calc RPM:	1785.0	BHP:	189	Calc PS FPM:	892.5

#### Driver Data:

Type:	Electric
Mfg:	
Model:	
BHP:	250
Avail:	250 (0)

[Disch Temp VALVES](#)

#### Services

Gas Model

#### Service 1

VMG

#### Stage Data:

	<b>1 (SG)</b>	<b>2</b>	<b>3</b>	<b>4</b>
Target Flow, SCFM	380.000	380.000	380.000	380.000
Flow Calc, SCFM	430.215	430.215	430.216	430.221
BHP per Stage	42.5	43.1	50.5	46.7
Specific Gravity	0.6000	0.5997	0.5997	0.5997
Ratio of Sp Ht (N)	1.2681	1.2601	1.2696	1.2757
Comp Suct (Zs)	0.9912	0.9817	0.9520	0.8660
Comp Disch (Zd)	0.9883	0.9791	0.9600	1.0144
Pres Suct Line, psig	35.00	N/A	N/A	N/A
Pres Suct Flg, psig	32.00	127.19	370.09	1293.34
Pres Disch Flg, psig	131.77	379.75	1308.58	4545.13
Pres Disch Line, psig	N/A	N/A	N/A	4500.00
Pres Ratio F/F	3.198	2.796	3.447	3.488
Temp Suct, °F	60.00	125.00	125.00	125.00
Temp Clr Disch, °F	125.00	125.00	125.00	125.00

#### Cylinder Data:

	<b>Throw 2</b>	<b>Throw 2</b>	<b>Throw 1</b>	<b>Throw 1</b>
Cyl Model	<a href="#">10-3/4P-HE</a>	5-1/2P-CE	3-3/4SG-CE	1-3/4SG-FS-HE
Cyl Bore, in	10.750	5.500	3.750	1.625
Cyl RDP (API), psig	200.0	477.3	2318.2	5545.5
Cyl MAWP, psig	225.0	525.0	2550.0	6100.0
Cyl Action	HE	CE	CE	HE
Cyl Disp, CFM	281.3	70.5	31.1	6.4
Pres Suct Intl, psig	28.92	116.54	341.49	1260.94
Temp Suct Intl, °F	67	130	131	130
Pres Disch Intl, psig	137.61	408.45	1392.12	4669.22
Temp Disch Intl, °F	230	293	<a href="#">331</a>	321
HE Suct Gas Vel, FPM	8632	N/A	N/A	5155
HE Disch Gas Vel, FPM	6319	N/A	N/A	5608
HE Spcrs Used/Max	1/2	N/A	N/A	0/2
HE Vol Pkt Avail, %	No Pkt	N/A	N/A	No Pkt
Vol Pkt Used, %	No Pkt	N/A	N/A	No Pkt
HE Min Clr, %	16.71	N/A	N/A	14.62
HE Total Clr, %	29.19	N/A	N/A	14.62
CE Suct Gas Vel, FPM	N/A	9600	9383	N/A
CE Disch Gas Vel, FPM	N/A	8857	8366	N/A
CE Spcrs Used/Max	N/A	0/2	0/2	N/A
CE Min Clr, %	N/A	17.88	22.14	N/A
CE Total Clr, %	N/A	17.88	22.14	N/A
Suct Vol Eff HE/CE, %	49.8/N/A	N/A/71.1	N/A/57.4	74.3/N/A
Disch Event HE/CE, ms	4.6/N/A	N/A/6.8	N/A/5.6	5.5/N/A
Suct Pseudo-Q HE/CE	6.6/N/A	N/A/8.3	N/A/7.3	3.9/N/A
Gas Rod Ld Comp, %	69.9 C	69.9 C	87.0 C	87.0 C
Gas Rod Ld Tens, %	88.2 T	88.2 T	80.6 T	80.6 T
Gas Rod Ld Total, %	82.5	82.5	88.1	88.1
Xhd Pin Deg/%RvrsI lbf	147/62.5	147/62.5	178/63.0	178/63.0
Flow Calc, SCFM	430.215	430.215	430.216	430.221
Cyl BHP	42.5	43.1	50.5	46.7

**THIS PAGE LEFT INTENTIONALLY BLANK**

# **ARIEL OPERATORS MANUAL**

**THIS PAGE LEFT INTENTIONALLY BLANK**



	Throw #1	Throw #2	
Parts Group	3.750SG-CE	5.500P-CE	
	CE SN: C136419	CE SN: C136421	
	1.625SG-FS-HE	10.750P-HE	
	HE SN: C136420	HE SN: C136422	
	P/N LB	P/N LB	
	AD-1043 14.59	AD-1043 14.65	
Connecting Rod with Bushing, bolts and bearing shells			
	C-6029 18.86	C-6000 37.16	
Piston(s) with rings, rod, collar & nut or stub shaft		C-5974 C-6001	
	D-0061 19.20	D-3284 8.04	
Crosshead with bushings			
	A-0377 8.69	B-0015 0.66	
Crosshead nut with setscrews			
Total Recip Weight Max: 103.20	61.34	60.51	
Imbalance Max: 1.00	0.83		









**ARIEL CORPORATION**  
**Recommended Spares Start-Up**

Mon Aug 20 09:27:36 EDT 2012

**F39114**  
**C136420, C136421, C136422, C136419**

**Project:**

QTY	Part Number	Description	Your Price	Net Amount
<b>JGN-JGQ FRAME CLASS</b>				
1	B-0104	GSKT,RET, TOP CVR,M:P, 1/32	\$0.0000	\$0.00
2	A-0067	GSKT,RET,9-1/2X6-7/16X1/32	\$0.0000	\$0.00
1	A-0661	LO FILTER ELEMENT,SPIN-ON	\$0.0000	\$0.00
4	A-3540	RUPTURE DISC,7300 PSIG,BLUE	\$0.0000	\$0.00
			<b>Sub Total</b>	<b>\$0.00</b>
<b>CYL ASSY1-5/8SG-HE X3-3/4SG-CE</b>				
2	A-1812	O-RING,VT, 3.887 O.D. X .139	\$0.0000	\$0.00
1	A-12084	STL GASKET, 2.438 X 2.125 X60	\$0.0000	\$0.00
1	B-1788-E	CONC VLV,078/035 1-3/4,1-5/8	\$0.0000	\$0.00
			<b>Sub Total</b>	<b>\$0.00</b>
<b>CYL ASSY, 5-1/2P-CE,STD 525</b>				
2	A-17591	STL GASKET, 5.813 X 5.625 X 60	\$0.0000	\$0.00
2	A-15600	STL GASKET, 3.575 X 3.406 X 30	\$0.0000	\$0.00
2	A-0026	O-RING,VT, 3.895 O.D. X .210	\$0.0000	\$0.00
1	B-5092-N	DIS VLV, 79CRE,PKX	\$0.0000	\$0.00
1	B-5091-CC	SUC VLV, 79CRE,MTX	\$0.0000	\$0.00
			<b>Sub Total</b>	<b>\$0.00</b>
<b>CYL ASSY,10-3/4P-HE,STD 225</b>				
2	A-0469	O-RING,VT,13.395 O.D. X .210	\$0.0000	\$0.00
1	A-0653	O-RING,VT,12.395 O.D. X .210	\$0.0000	\$0.00
1	A-10434	O-RING,VT, 6.512 O.D. X .139	\$0.0000	\$0.00
1	A-15072	O-RING,VT,11.895 O.D. X .210	\$0.0000	\$0.00
1	B-5840-GG	CONC VLV,147CT/256CFS	\$0.0000	\$0.00
			<b>Sub Total</b>	<b>\$0.00</b>
<b>CYL ASSY, 3-3/4SG-CE 2550</b>				
2	A-13933	STL GASKET, 4.000 X 3.813 X 60	\$0.0000	\$0.00
4	A-0027	O-RING,VT, 2.520 O.D. X .210	\$0.0000	\$0.00
1	A-3250	THUMB SCREW,NYLON,1/4-20 X1/2	\$0.0000	\$0.00
2	A-13192	STL GASKET, 2.250X 2.438X 60	\$0.0000	\$0.00
1	B-3712-M	DIS VLV, 52RX ,PKX	\$0.0000	\$0.00
1	B-4087-BB	SUC VLV, 52RX ,MTX	\$0.0000	\$0.00
			<b>Sub Total</b>	<b>\$0.00</b>
			<b>Start-Up Grand Total</b>	<b>\$0.00</b>





**ARIEL CORPORATION**  
**Recommended Spares Consumables**

Mon Aug 20 09:27:36 EDT 2012

**F39114**

**C136420, C136421, C136422, C136419**

**Project:**

QTY	Part Number	Description	Your Price	Net Amount
<b>JGN-JGQ FRAME CLASS</b>				
1	B-0104	GSKT,RET,TOP CVR,M:P, 1/32	\$0.0000	\$0.00
4	A-0067	GSKT,RET,9-1/2X6-7/16X1/32	\$0.0000	\$0.00
4	A-18496	CHK VLV,DBL BALL,SS,1/4TX1/8P	\$0.0000	\$0.00
1	A-8723-K	FILTER KIT, LUBRICATOR 150 MIC	\$0.0000	\$0.00
1	A-18526-A	FF LUBR PUMP 1/4 ARIEL,REPL	\$0.0000	\$0.00
1	A-0080	BLOW-OUT ASSY,SPECIFY DISC.	\$0.0000	\$0.00
2	A-0661	LO FILTER ELEMENT,SPIN-ON	\$0.0000	\$0.00
4	A-3540	RUPTURE DISC,7300 PSIG,BLUE	\$0.0000	\$0.00
1	A-3535	RUPTURE DISC ASSY,7300 PSI	\$0.0000	\$0.00
			<b>Sub Total</b>	<b>\$0.00</b>
<b>CYL ASSY1-5/8SG-HE X3-3/4SG-CE</b>				
2	A-1812	O-RING,VT, 3.887 O.D. X .139	\$0.0000	\$0.00
2	A-18496	CHK VLV,DBL BALL,SS,1/4TX1/8P	\$0.0000	\$0.00
2	A-12084	STL GASKET, 2.438 X 2.125 X60	\$0.0000	\$0.00
1	A-1843	VLV RING, 35CD10	\$0.0000	\$0.00
1	A-1844	VLV RING, 78CD	\$0.0000	\$0.00
6	A-1845	LENTOID SPRING, CONCENTRIC VLV	\$0.0000	\$0.00
6	A-1846	ANNULAR SPRING,35CD1,CONC VLV	\$0.0000	\$0.00
1	A-1848	COUNTER RING,78C1,CONC VLV	\$0.0000	\$0.00
1	A-1367	LOCKNUT, DRAKE 3/8-24	\$0.0000	\$0.00
1	A-4876	UPPER PART CONC VLV	\$0.0000	\$0.00
1	A-4877-A	LOWER PART ASSY,CONCENTRIC VLV	\$0.0000	\$0.00
			<b>Sub Total</b>	<b>\$0.00</b>
<b>CYL ASSY, 5-1/2P-CE,STD 525</b>				
2	A-17591	STL GASKET, 5.813 X 5.625 X 60	\$0.0000	\$0.00
2	A-18496	CHK VLV,DBL BALL,SS,1/4TX1/8P	\$0.0000	\$0.00
3	A-0237	PISTON RING, 5-1/2R:M:P:H:RJ	\$0.0000	\$0.00
1	B-2650-K	RBLD KIT,PIST ROD PKG,1.125	\$0.0000	\$0.00
1	A-15636-A	DIS VLV SEAT ASSY, 79CRE	\$0.0000	\$0.00
1	KB-5092-N	KIT,VLV, 79CRE,PKX	\$0.0000	\$0.00
2	A-1367	LOCKNUT, DRAKE 3/8-24	\$0.0000	\$0.00
3	A-1735	GUIDE RING,70RX,.205 THK	\$0.0000	\$0.00
1	A-15639	SUC VLV SEAT, 79CRE	\$0.0000	\$0.00
1	KB-5091-CC	KIT,VLV, 79CRE,MTX	\$0.0000	\$0.00

			Sub Total	\$0.00
<b>CYL ASSY,10-3/4P-HE,STD 225</b>				
2	A-0469	O-RING,VT,13.395 O.D. X .210	\$0.0000	\$0.00
4	A-18496	CHK VLV,DBL BALL,SS,1/4TX1/8P	\$0.0000	\$0.00
2	A-17457	PISTON RING, 10-3/4P-HE	\$0.0000	\$0.00
1	A-0653	O-RING,VT,12.395 O.D. X .210	\$0.0000	\$0.00
1	A-10434	O-RING,VT, 6.512 O.D. X .139	\$0.0000	\$0.00
1	A-15072	O-RING,VT,11.895 O.D. X .210	\$0.0000	\$0.00
1	A-1462	LOCKNUT, DRAKE,3/4-16	\$0.0000	\$0.00
1	A-17910	GUIDE RING,147CT/256CFS.441THK	\$0.0000	\$0.00
1	A-17908-A	UPPER PART ASSY,CONCENTRIC VLV	\$0.0000	\$0.00
1	A-17909-A	LOWER PART ASSY,CONCENTRIC VLV	\$0.0000	\$0.00
1	KB-5840-GG	KIT,CONC VLV,147CT/256CFS	\$0.0000	\$0.00
1	A-2858	WAFER PLATE.147CHT	\$0.0000	\$0.00
			Sub Total	\$0.00
<b>CYL ASSY, 3-3/4SG-CE 2550</b>				
2	A-13933	STL GASKET, 4.000 X 3.813 X 60	\$0.0000	\$0.00
6	A-0027	O-RING,VT, 2.520 O.D. X .210	\$0.0000	\$0.00
2	A-18496	CHK VLV,DBL BALL,SS,1/4TX1/8P	\$0.0000	\$0.00
4	A-19365	PISTON RING, 1-5/8SG,PK	\$0.0000	\$0.00
2	A-7266	PISTON RING, 1-5/8JG:SG,PK,SJ	\$0.0000	\$0.00
4	A-17854	RIDER RING, 3-3/4SG,SJ	\$0.0000	\$0.00
1	B-2648-K	RBLD KIT,PIST ROD PKG,1.125	\$0.0000	\$0.00
1	A-7265	WEAR BAND, 1-5/8JG:SG,.875W	\$0.0000	\$0.00
1	A-12180-A	DIS VLV SEAT ASSY, 52RX THK	\$0.0000	\$0.00
1	KB-3712-M	KIT,VLV, 52RX ,PKX	\$0.0000	\$0.00
4	A-10357	GUIDE RING,52RX,.279 THK	\$0.0000	\$0.00
2	A-1366	LOCKNUT, DRAKE,5/16-24	\$0.0000	\$0.00
1	A-12991	SUC VLV SEAT, 52RX	\$0.0000	\$0.00
1	KB-4087-BB	KIT,VLV, 52RX ,MTX	\$0.0000	\$0.00
			Sub Total	\$0.00
			Consumables Grand Total	\$0.00





**ARIEL CORPORATION**  
**Recommended Spares Insurance**

Mon Aug 20 09:27:36 EDT 2012

**F39114**

**C136420, C136421, C136422, C136419**

**Project:**

QTY	Part Number	Description	Your Price	Net Amount
<b>JGN-JGQ FRAME CLASS</b>				
2	FP0500FE	DOWEL PIN, 1/4 X 3/4 +.0002	\$0.0000	\$0.00
1	A-0203	CHAIN,35-1 X 94	\$0.0000	\$0.00
1	FW0500GA	FLAT WASHER, 1/2 SAE	\$0.0000	\$0.00
2	B-0003	BUSHING,BZ,ROD,JG:A:M:P:S:I	\$0.0000	\$0.00
4	B-0023	SLEEVE BRG,H/S,ROD,JG:M:P:S	\$0.0000	\$0.00
1	B-0104	GSKT,RET,TOP CVR,M:P, 1/32	\$0.0000	\$0.00
3	B-0024	SLEEVE BRG,H/S,MAIN,JG:M:P:S	\$0.0000	\$0.00
1	B-0025	SLEEVE BRG,H/S,THRUST,JG:M:P:S	\$0.0000	\$0.00
6	B-0002	BUSHING,BZ,XHD,JG:N:A:Q	\$0.0000	\$0.00
1	A-0059	12 PT,3/8 -24 X 5,SPCL	\$0.0000	\$0.00
2	FN0461EA	SELF-LOCK NUT,ESNA,3/8-24	\$0.0000	\$0.00
1	A-0060	CROSSHEAD PIN,JG:A:M:P:I:S	\$0.0000	\$0.00
2	A-0194	GSKT,RND,OIL SEAL,1/32	\$0.0000	\$0.00
2	A-0245	DUST SEAL,TFE,JG:A:M:P:N:Q	\$0.0000	\$0.00
2	A-3763	CHK VLV,1/8MX1/8F,SS,PPT/14PSI	\$0.0000	\$0.00
1	A-0077	SIGHT GLASS,1" NPT	\$0.0000	\$0.00
1	A-5641	SIGHT GLASS,3/4" NPT	\$0.0000	\$0.00
1	A-18526-A	FF LUBR PUMP 1/4 ARIEL,REPL	\$0.0000	\$0.00
1	A-0068	GSKT,RND,5-1/4X1/32	\$0.0000	\$0.00
1	A-0073	GSKT,NST,1/32,M:P:I:JG/2,TUT	\$0.0000	\$0.00
1	A-18450-A	GAUGE,100PSI,REPL,BOTTOM MOUNT	\$0.0000	\$0.00
1	A-17258-A	GAUGE,7500PSI,REPL,BACK MOUNT	\$0.0000	\$0.00
1	A-13894	FF.S/D,PRO-FLO-JR,TRAB	\$0.0000	\$0.00
1	L-00765	18T-18T-9T-6S	\$0.0000	\$0.00
			<b>Sub Total</b>	<b>\$0.00</b>
<b>CYL ASSY1-5/8SG-HE X3-3/4SG-CE</b>				
2	A-0039	O-RING,VT, 4.020 O.D. X .210	\$0.0000	\$0.00
2	A-1812	O-RING,VT, 3.887 O.D. X .139	\$0.0000	\$0.00
2	A-12084	STL GASKET, 2.438 X 2.125 X60	\$0.0000	\$0.00
1	B-1788-E	CONC VLV,078/035 1-3/4,1-5/8	\$0.0000	\$0.00
			<b>Sub Total</b>	<b>\$0.00</b>
<b>CYL ASSY, 5-1/2P-CE,STD 525</b>				
2	A-0065	GSKT,RND,12 X 1/64	\$0.0000	\$0.00
2	A-3511	O-RING,VT,10.395 O.D. X .210	\$0.0000	\$0.00
1	A-0057	PISTON COLLAR, 2-1/2=8JG:MP	\$0.0000	\$0.00

1	C-6001	P ROD, 3.00STK/23.689LG	\$0.0000	\$0.00
2	A-15600	STL GASKET, 3.575 X 3.406 X 30	\$0.0000	\$0.00
2	A-0026	O-RING,VT, 3.895 O.D. X .210	\$0.0000	\$0.00
1	B-5092-N	DIS VLV, 79CRE,PKX	\$0.0000	\$0.00
1	B-5091-CC	SUC VLV, 79CRE,MTX	\$0.0000	\$0.00
			<b>Sub Total</b>	<b>\$0.00</b>
<b>CYL ASSY,10-3/4P-HE,STD 225</b>				
2	A-0469	O-RING,VT,13.395 O.D. X .210	\$0.0000	\$0.00
1	B-0019	PISTON NUT, 2-1/4"THRU 8"JG:MP	\$0.0000	\$0.00
1	A-0653	O-RING,VT,12.395 O.D. X .210	\$0.0000	\$0.00
1	A-10434	O-RING,VT, 6.512 O.D. X .139	\$0.0000	\$0.00
1	A-15072	O-RING,VT,11.895 O.D. X .210	\$0.0000	\$0.00
1	B-5840-GG	CONC VLV,147CT/256CFS	\$0.0000	\$0.00
			<b>Sub Total</b>	<b>\$0.00</b>
<b>CYL ASSY, 3-3/4SG-CE 2550</b>				
2	A-0065	GSKT,RND,12 X 1/64	\$0.0000	\$0.00
6	A-0027	O-RING,VT, 2.520 O.D. X .210	\$0.0000	\$0.00
1	C-6029	PIST/ROD, 3.750 X 1.625SA	\$0.0000	\$0.00
1	A-3250	THUMB SCREW,NYLON,1/4-20 X1/2	\$0.0000	\$0.00
2	A-13192	STL GASKET, 2.250X 2.438X 60	\$0.0000	\$0.00
1	B-3712-M	DIS VLV, 52RX ,PKX	\$0.0000	\$0.00
1	B-4087-BB	SUC VLV, 52RX ,MTX	\$0.0000	\$0.00
			<b>Sub Total</b>	<b>\$0.00</b>
			<b>Insurance Grand Total</b>	<b>\$0.00</b>

All amounts are in US dollars and price is subject to change at any time.

---

ARIEL CORPORATION, 35 BLACKJACK ROAD, MOUNT VERNON, OHIO 43050 USA  
PHONE: 740-397-0311 FAX: 740-397-3856

Printed: Mon Aug 20 09:27:36 EDT 2012  
© 2012 ARIEL CORPORATION

**THIS PAGE LEFT INTENTIONALLY BLANK**

# ARIEL Heavy Duty Balanced Opposed Compressors

TECHNICAL MANUAL  
For Models:

JGM, JGN, JGP and JGQ;  
and JGI Vertical Non-Balanced



ARIEL CORPORATION  
35 BLACKJACK ROAD, MOUNT VERNON, OHIO 43050  
TELEPHONE: 740-397-0311 FAX: 740-397-3856  
VISIT OUR WEB SITE: [www.arielcorp.com](http://www.arielcorp.com)

REV: 1/99

**THIS PAGE LEFT INTENTIONALLY BLANK**

## CAUTION

**GAS COMPRESSOR UNITS ARE COMPLICATED AND DANGEROUS PIECES OF EQUIPMENT, IF YOU ARE NOT FULLY TRAINED AND FAMILIAR WITH THEIR OPERATION.**

**BEFORE STARTING THIS UNIT:**

**FAMILIARIZE YOURSELF WITH THE UNIT.**

**READ AND STUDY START-UP AND SHUT-DOWN INFORMATION FOR BOTH PACKAGE AND COMPRESSOR CAREFULLY!**

**A GAS/AIR MIXTURE UNDER PRESSURE CAN EXPLODE! YOU CAN BE SEVERELY INJURED OR KILLED. MAKE SURE THE COMPRESSOR IS SUFFICIENTLY PURGED OF ANY EXPLOSIVE MIXTURE BEFORE LOADING.**

**AFTER COMPLETING THE ABOVE, BEGIN PROPER STARTING PROCEDURE.**



## CAUTION

**DO NOT ATTEMPT TO START-UP UNIT WITHOUT REFERRING TO THIS MANUAL SECTION 1 -"START UP". IT IS ALSO ESSENTIAL TO REFER TO THE PACKAGER'S OPERATING MANUAL.**

## CAUTION

**THIS MANUAL EDITION IS BASED ON THE CURRENT DESIGN AND BUILD PRACTICES. THIS MANUAL MAY NOT BE APPLICABLE TO EQUIPMENT BUILT PRIOR TO THE DATE ON FRONT COVER AND IS SUBJECT TO CHANGE WITHOUT NOTICE. CONTACT ARIEL WITH ANY QUESTIONS. REFER TO LAST PAGE OF THIS MANUAL FOR CONTACT INFORMATION.**



**WHEN THIS SYMBOL APPEARS ON THE COMPRESSOR OR CONTROL PANEL, THIS TECHNICAL MANUAL IS TO BE CONSULTED FOR SPECIFIC INFORMATION BEFORE PROCEEDING. IF MORE INFORMATION IS NEEDED CONTACT YOUR PACKAGER AND/OR ARIEL CORPORATION.**

**THIS PAGE LEFT INTENTIONALLY BLANK**

# TABLE OF CONTENTS

<b>Design Specifications &amp; Data .....</b>	<b>1-1</b>
General .....	1-1
Specifications .....	1-3
Opposed Throw - Reciprocating Weight Balancing .....	1-5
Product Information and Safety Plates .....	1-6
Important Safety & Data Information .....	1-7
Clearances .....	1-10
Piston Ring and Packing Ring Side Clearance, Inches (mm) .....	1-11
Fastener Tightening Torque .....	1-15
Tightening Torque Procedures .....	1-19
Ariel Bolting .....	1-21
Zone 1 Environment .....	1-21
<b>Installation .....</b>	<b>2-1</b>
The Skid or Package .....	2-1
Lifting the Compressor .....	2-1
Setting the Compressor .....	2-2
Leveling Limits for Compressors .....	2-3
Aligning Main Bearing Bores .....	2-3
Alignment - to Driver .....	2-6
Electrical Grounding .....	2-11
Pneumatically Actuated Unloaders & Clearance Devices .....	2-11
Vents and Drains .....	2-11
BICERA Type Crankcase Over-Pressure Relief Valves .....	2-12
<b>Start Up .....</b>	<b>3-1</b>
General .....	3-1
Start Up Check List .....	3-1
Warranty Notification - Installation List Data and Start Up Check Lists for JG:A:M:N:P:Q:R:J:H:E:K:T:C:D Reciprocating Compressors .....	3-2
Maximum Allowable Working Pressure .....	3-10
Relief Valve Settings .....	3-11
Filling Sump & Priming a Main Oil Lube Oil System - Before Starting .....	3-11
Filling The Sump .....	3-11
Priming - Main Lube Oil System .....	3-12
Compressor Prelube .....	3-12
Force Feed Lubricator Adjustment .....	3-12
Compressor Re-Application .....	3-12
<b>Lubrication .....</b>	<b>4-1</b>
General .....	4-1
Lubrication Functions .....	4-1



Lubricant Characteristics ..... 4-2

    Viscosity ..... 4-2

    Viscosity Index ..... 4-3

    Pour Point ..... 4-3

    Flash Point ..... 4-3

Lubricant Base Stock ..... 4-3

    Petroleum-Based Lubricants (also referred to as mineral oils) ..... 4-3

    Synthetic Lubricants ..... 4-4

Lubricant Formulations ..... 4-5

    Compounded Cylinder Oils ..... 4-5

    R&O Oil ..... 4-5

    Engine Oil ..... 4-5

    Used Engine Oil ..... 4-6

    Gear Oil ..... 4-6

FRAME OIL SYSTEM ..... 4-7

    COMPONENTS ..... 4-7

    Oil Strainer ..... 4-7

    Oil Pump ..... 4-7

    Oil Cooler ..... 4-7

    Oil Temperature Control Valve ..... 4-8

    Oil Filtration ..... 4-8

    Compressor Prelube Pump ..... 4-9

    Oil Heaters ..... 4-9

    Lube Oil Analysis Sampling Point ..... 4-10

    Cold Starting ..... 4-11

    Dry Sump ..... 4-12

FRAME OIL OPERATING CONDITIONS ..... 4-13

    Compressor Frame Lubricant ..... 4-13

    Oil Viscosity ..... 4-14

    Oil Pressure ..... 4-14

    Oil Temperature ..... 4-14

    Oil Maintenance ..... 4-15

    Oil Sampling ..... 4-15

Oil System Cleanliness ..... 4-15

Cylinder and Packing Lubrication ..... 4-17

    Independent Force Feed Lubricator Systems ..... 4-17

    Common Oil Supply ..... 4-17

    Independent Oil Supply ..... 4-18

Force Feed Lubrication System Components ..... 4-18

    Gas Inlet Debris Screens to Maintain Lube Performance ..... 4-18

    Injection Oil Inlet Filter ..... 4-19

    Oil Dilution ..... 4-19

    Cylinder Oil Lubrication Examples ..... 4-19

    Under/Over Lube ..... 4-19

    Inadequate Lubrication Symptoms ..... 4-20

    Lubrication Quantity - Paper Test Method ..... 4-20

    Lubricator Cycle Time ..... 4-20

    Cycle Time Indication ..... 4-21

    Force Feed Lubrication System Monitoring: ..... 4-21

Minimum Requirements .....	4-21
Devices .....	4-21
Choosing a Lube System Monitor .....	4-22
Break-in Rate .....	4-25
Liquids in Gas .....	4-25
Lube Type & Rate Recommendations .....	4-26
RATE CALCULATION NOTES .....	4-28
Water-Cooled Packing .....	4-30
Coolant System Requirements .....	4-31
Force Feed Lubrication System - Description .....	4-31
Force Feed Lubricator Adjustment .....	4-32
Blow-Out Fittings, Rupture Disks and Tubing .....	4-32
Divider Valves .....	4-34
Description .....	4-34
Divider Valve Block Assembly Instructions .....	4-35
Operation - (see Figure 4-13 and Figure 4-14) .....	4-35
Pressure Testing For Divider Valve By-Passing .....	4-38
Electronic Lubricator Fluid-Flow Monitor/No-Flow Timer Switch - Proflo PF1 .....	4-39
Proflo PF1 Monitor wiring identification and instructions for electronic indication: .....	4-40
Proflo PF1 Button Operation: .....	4-41
Downloading Proflo PF1 Data: .....	4-41
Proflo PF1 Setup Alarm Time and Mode: .....	4-42
Proflo PF1 Battery Replacement: .....	4-43
Proflo PF1 Display Errors: .....	4-44
Proflo PF1 Operation Notes: .....	4-45
Proflo Normally Open and Normally Closed Definition: .....	4-46
Proflo PF1 - Using Pulse Output and Alarm Circuit at Same Time: .....	4-47
Proflo PF1 - Using PLC to Calculate Oil Consumption: .....	4-48
Proflo PF1 Accessories Available: .....	4-49
Protection of Electronics & the Compressor When Arc Welding .....	4-49
Electronic-Lubricator Digital No-Flow Timer Switch (DNFT) .....	4-49
Replacing the (Field-Replaceable) Battery in the DNFT: .....	4-50
Oil Head at Lube Points .....	4-51
Force Feed Lubrication System and Running Conditions .....	4-51
Force Feed Lubrication System .....	4-51
Running Conditions .....	4-52
System Design Considerations and Operating Parameters .....	4-52
Force Feed Balance Valves .....	4-52
Setting and Maintaining Balance Valves .....	4-52
Checking/Adjusting Balance Valves on Subsequent Start-up .....	4-53
Frame Lubricating System - Description .....	4-54
Lube Oil Strainer, Filter & Filter Installation Instructions .....	4-54
Lube Oil Strainer .....	4-54
Lube Oil Filter .....	4-55
Oil Filter Installation for Spin-On Type Filters .....	4-55
Oil Filter Element Installation for Cartridge Type Filters .....	4-55
Lube Oil Pump & Lube Oil Pressure .....	4-57
Description & Adjustment .....	4-57
Lube Oil Pressure Regulating Valve .....	4-57

Low Oil Pressure Shutdown ..... 4-58

**Maintenance ..... 5-1**

General Introduction ..... 5-1

    Compressor Components ..... 5-3

Positioning a Throw for Maintenance ..... 5-3

Connecting Rod ..... 5-4

    Connecting Rod (Crank Pin) Bearing ..... 5-4

    Connecting Rod - Removal ..... 5-6

    Connecting Rod Bushing Replacement ..... 5-7

    Connecting Rod - Installation ..... 5-8

Crosshead..... 5-11

    Crosshead - Removal ..... 5-11

    Crosshead - Installation ..... 5-13

Crankshaft ..... 5-14

    Main Bearings - Checking Clearances ..... 5-14

    Crankshaft - Removal ..... 5-17

    Oil Slinger - Removal ..... 5-18

    Oil Slinger - Installation ..... 5-18

    Chain Sprocket - Removal ..... 5-18

    Chain Sprocket - Installation ..... 5-19

    Fan Shaft Assembly Procedure ..... 5-19

    Main Bearings - Removal and Installation w/Crankshaft Removed ..... 5-20

    Main Bearings - Removal and Installation w/Crankshaft In Place ..... 5-21

Crankshaft - Installation ..... 5-22

Chain Drive System ..... 5-23

    Description ..... 5-23

    Chain Adjustment ..... 5-24

    Chain and Sprocket Replacement ..... 5-24

    Chain Idler Sprocket Replacement - (Eccentric Adjustment Cap) ..... 5-25

    Lube Oil Pump Chain Sprocket Replacement ..... 5-25

    Force Feed Lubricator Chain Sprocket Replacement ..... 5-26

Piston and Rod ..... 5-27

    Piston and Rod - Removal ..... 5-27

    Piston and Rod Disassembly ..... 5-28

    Piston and Rod Reassembly ..... 5-29

    Piston and Rod - Installation ..... 5-30

Piston Rod Run Out ..... 5-31

Piston Rings ..... 5-32

    Determining Ring Wear: ..... 5-32

    Removal: ..... 5-32

    Piston Rings - Installation ..... 5-32

Wear Bands ..... 5-32

    Determining Wear Band Wear: ..... 5-33

    Wear Band - Installation ..... 5-33

Piston Rod Pressure Packing - Removal ..... 5-33

Piston Rod Packing - Reassembly ..... 5-34

Types of Piston Rod Packing Rings ..... 5-35

Type "P" Pressure Breaker .....	5-35
Type "BTR" Single Acting Seal Set .....	5-36
Type "AL" Double Acting Seal Set .....	5-36
Type "BD" Double Acting Seal Set .....	5-36
Type "3RWS" Oil Wiper Set .....	5-37
Typical Arrangement of Piston Rod Packing Rings .....	5-37
Piston Rod Packing Ring Material .....	5-37
Water-Cooled Piston Rod Packing .....	5-38
Reassembly .....	5-38
Testing .....	5-38
Valves .....	5-39
Valves - Removal .....	5-39
Valves - Maintenance .....	5-40
Valves - Reassembly .....	5-41
Bolt Tightening for Valve Caps .....	5-42
VVCP - Head-End Variable Volume Clearance Pocket .....	5-43
VVCP - Removal .....	5-44
VVCP - Disassembly .....	5-44
VVCP - Maintenance .....	5-45
VVCP - Adjustment .....	5-45
Compressor Cylinder Re-Boring & Bore Restoration Guidelines .....	5-46
Ethylene Glycol Contamination .....	5-47
<b>Technical Assistance .....</b>	<b>6-1</b>
Recommended Maintenance Intervals .....	6-1
Daily .....	6-1
Monthly (in addition to Daily Requirements) .....	6-2
Every 6 Months or 4000 Hours (plus Daily/Monthly) .....	6-3
Yearly or 8000 Hours (plus Daily/Monthly/6 Months) .....	6-3
Every 2 Years or 16,000 Hours (plus Daily/Monthly/6 Months/Yearly) .....	6-4
Every 4 Years or 32,000 Hours (plus Daily/Monthly/6 Months/1 & 2 Years) .....	6-4
Every 6 Years or 48,000 hours (plus Daily/Monthly/6 Months/1, 2 & 4 Years) .....	6-5
Trouble Shooting .....	6-5
<b>Appendices .....</b>	<b>7-1</b>
Ariel Tools .....	7-1
Ariel Furnished Tools .....	7-1
Ariel Tools - Purchased Separately From Authorized Dealer .....	7-3
Minimum Hand & Commercial Tools Required .....	7-3
Gas Analysis Common Abbreviations .....	7-7
Technical and Service Schools on Ariel Compressors .....	7-7
Ariel Customer Technical Bulletins .....	7-8
Vendor Literature .....	7-8
Ariel Contact Information .....	7-8



# SECTION 1 - DESIGN SPECIFICATIONS & DATA

## General

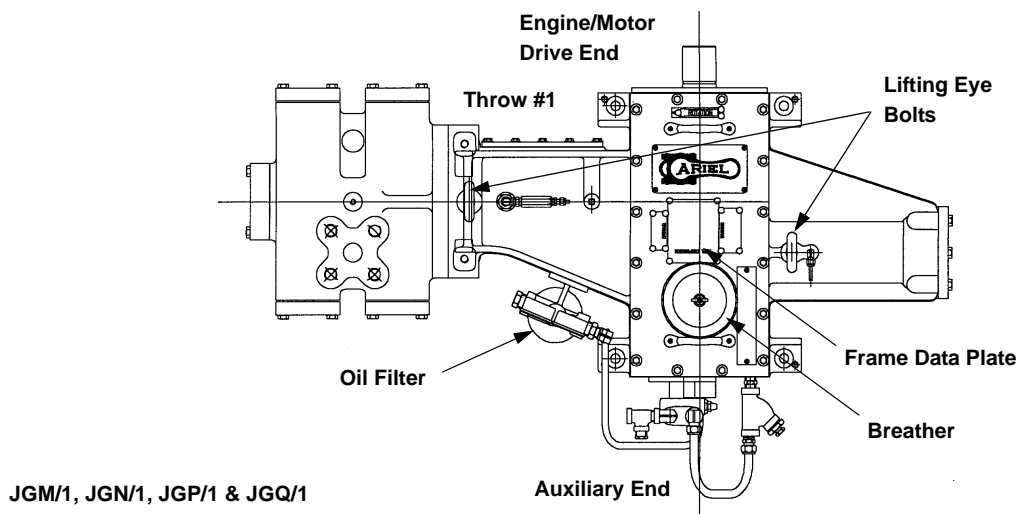
Ariel compressors are designed for ease of operation and maintenance. Experience has shown that an Ariel compressor will normally provide years of satisfactory performance with minimal maintenance.

While Ariel compressors share many similarities, each model has aspects that are unique to the particular type. If you as an operator are familiar with Ariel compressors, it is still important to review this manual to determine the differences. If you are new to Ariel compressors it is critical that you become very familiar with this manual prior to operating the compressor.

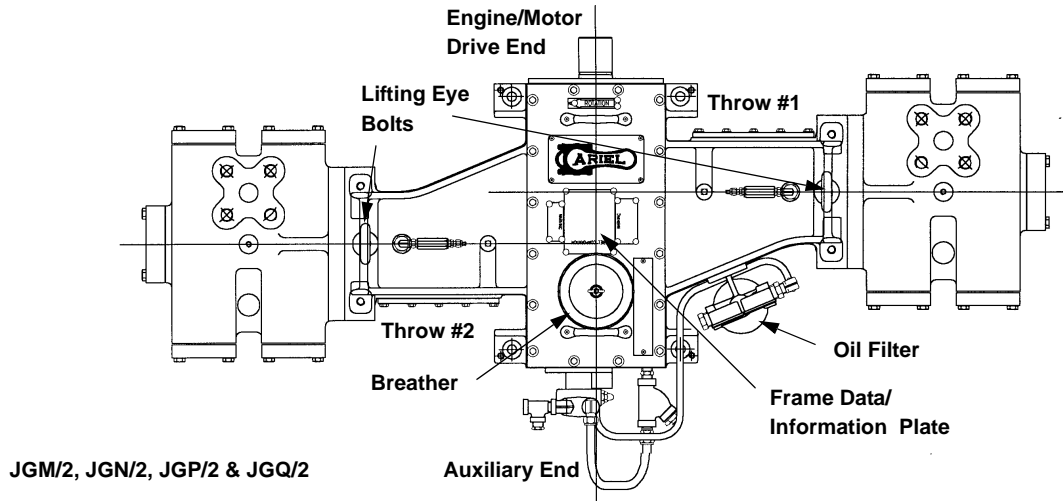
This manual is designed to provide information on installation, start up, operation and maintenance of a JGI, JGM, JGN, JGP or JGQ compressor. If you have any questions please contact your Packager. If they are unable to provide resolution, they will refer your concerns to Ariel Corporation. If you prefer, you may always contact Ariel directly. Contact your Packager or the Ariel Response Center for detailed information. Refer to the last page of this manual for contact information.

This manual provides design specifications for standard current production equipment at publication date. Do not exceed data plates ratings for a particular compressor.

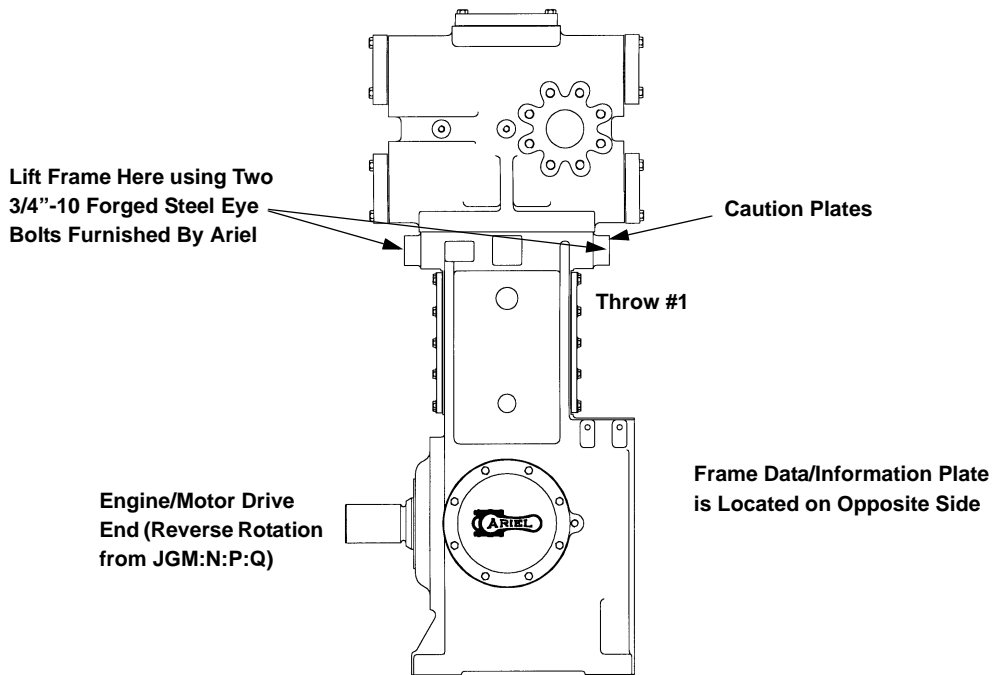
The location of the throws and the information shown on the Data Plates is very important when communicating questions concerning an Ariel compressor.



**FIGURE 1-1 TYPICAL COMPRESSOR THROW NUMBERING AND FRAME DATA PLATE LOCATION - JGM:N:N:Q/1 THROW (TOP VIEW)**



**FIGURE 1-2 TYPICAL COMPRESSOR THROW NUMBERING AND FRAME DATA PLATE LOCATION - JGM:N:P:Q/2 THROW (TOP VIEW)**



**FIGURE 1-3 COMPRESSOR THROW NUMBERING AND FRAME DATA PLATE LOCATION JGI/1 THROW - VERTICAL NON-BALANCED COMPRESSOR (SIDE VIEW)**

# Specifications

**TABLE 1-1 JGI, JGM & JGP FRAME SPECIFICATIONS**

MODEL <sup>a</sup>	JGI/1	JGM/1	JGM/2	JGP/1	JGP/2
Stroke, in. (mm)	3-1/2 (89)	3-1/2 (89)	3-1/2 (89)	3 (76)	3 (76)
Maximum Allowable Speed <sup>b</sup> , RPM	800	1500	1500	1800	1800
Minimum Speed <sup>c</sup> , RPM	400	750	750	900	900
Average Piston Speed <sup>d</sup> , FPM (m/s)	To 467 (2.37)	To 875 (4.45)	To 875 (4.45)	To 900 (4.57)	To 900 (4.57)
Number of Throws	1	1	2	1	2
Horsepower, to hp (kW)	55 (41)	84 (63)	168 (125)	85 (63)	170 (127)
Height - Bottom to Crankshaft Centerline, in. (mm)	10.250 (260.35)	9.250 (234.95)	9.250 (234.95)	9.250 (234.95)	9.250 (234.95)
Connecting Rod Centerline To Centerline, in. (mm)	8.250 (209.55)	8.250 (209.55)	8.250 (209.55)	8.250 (209.55)	8.250 (209.55)
Maximum Width with Cylinders, in. (m)	26 (0.66)	62 (1.58)	83 (2.11)	62 (1.58)	83 (2.11)
Maximum Length, in. (m)	31 (0.79)	35 (0.89)	35 (0.89)	35 (0.89)	35 (0.89)
Overall Height, in. (m)	53 (1.35) w/cylinder	17 (0.43) To Top of Aluminum Cover			
Approximate Weight with Cylinders, lb. (kg)	1300 (590)	1400 (640)	2000 (900)	1400 (640)	2000 (900)
Oil Pump Flow Rate <sup>e</sup> , GPM (L/s)	4 (0.25)	4 (0.25)	4 (0.25)	5 (0.32)	5 (0.32)
Oil Heat Rejection, BTU/hr (kW)	5600 (1.6)	8400 (2.5)	8400 (2.5)	16,800 (4.9)	16,800 (4.9)
Sump Capacity, US gallons (L)	4 (15)	2.5 (9)	2.5 (9)	2.5 (9)	2.5 (9)
Piston Rod Diameter, in. (mm)	1.125 (28.58)				
Internal Rod Load - Double Acting:					
Compression + Tension, lb <sub>f</sub> (kN)	12,000 (53)	12,000 (53)	12,000 (53)	12,000 (53)	12,000 (53)
Tension, lb <sub>f</sub> (kN)	6000 (27)	6000 (27)	6000 (27)	6000 (27)	6000 (27)
Compression, lb <sub>f</sub> (kN)	7000 (31)	7000 (31)	7000 (31)	7000 (31)	7000 (31)
Internal Rod Load - Single Acting:					
Tension, lb <sub>f</sub> (kN)	6000 (27)	6000 (27)	6000 (27)	6000 (27)	6000 (27)

- a. For more information, refer to the Electronic Data, available in the Ariel Performance Program.
- b. Maximum allowable speed is the highest (potential) speed at which the compressor frame design will permit continuous operation. Compressor frame data plate "Frame Rated Speed (RPM)" is application specific, and may be lower than Maximum Allowable Speed. The lower of the Frame Rated Speed, lowest cylinder rated (RPM) or driver rated speeds is not to be exceeded. If a JGI is to be run at higher speeds, the skid must have adequate mass for the vertical forces.
- c. Minimum Speed is the minimum frame speed to provide adequate oil flow to the compressor bearings.
- d. Average piston speed as is based on the maximum allowable speed (RPM) of the frame. The cylinder data-plate rated speed (RPM) or frame rated speed may be less, resulting in a lower piston speed rating.
- e. Flow rate is based on the maximum allowable frame speed rating and 180°F (82°C) oil.



**TABLE 1-2 JGN & JGQ FRAME SPECIFICATIONS**

MODEL <sup>a</sup>	JGN/1	JGN/2	JGQ/1	JGQ/2
Stroke, in. (mm)	3-1/2 (89)	3-1/2 (89)	3 (76)	3 (76)
Maximum Allowable Speed <sup>b</sup> , RPM	1500	1500	1800	1800
Minimum Speed <sup>c</sup> , RPM	750	750	900	900
Average Piston Speed <sup>d</sup> , FPM (m/s)	To 875 (4.45)	To 875 (4.45)	To 900 (4.57)	To 900 (4.57)
Number of Throws	1	2	1	2
Horsepower, to hp (kW)	126 (94)	252 (188)	140 (104)	280 (209)
Height - Bottom to Crankshaft Centerline, in. (mm)	9.250 (234.95)	9.250 (234.95)	9.250 (234.95)	9.250 (234.95)
Connecting Rod Centerline To Centerline, in. (mm)	8.250 (209.55)	8.250 (209.55)	8.250 (209.55)	8.250 (209.55)
Maximum Width with Cylinders, in. (m)	62 (1.58)	83 (2.11)	62 (1.58)	83 (2.11)
Maximum Length, in. (m)	35 (0.89)	35 (0.89)	35 (0.89)	35 (0.89)
Overall Height, in. (m)	17 (0.43) To Top of Aluminum Cover			
Approximate Weight with Cylinders, lb. (kg)	1400 (640)	2000 (900)	1400 (640)	2000 (900)
Oil Pump Flow Rate <sup>e</sup> , GPM (L/s)	4 (0.25)	4 (0.25)	5 (0.32)	5 (0.32)
Oil Heat Rejection, BTU/hr (kW)	8400 (2.5)	8400 (2.5)	16,800 (4.9)	16,800 (4.9)
Sump Capacity, US gallons (L)	2.5 (9)	2.5 (9)	2.5 (9)	2.5 (9)
Piston Rod Diameter, in. (mm)	1.125 (28.63)			
Internal Rod Load - Double Acting:				
Compression + Tension, lb <sub>f</sub> (kN)	18,000 (80)	18,000 (80)	20,000 (89)	20,000 (89)
Tension, lb <sub>f</sub> (kN)	9000 (40)	9000 (40)	10,000 (44)	10,000 (44)
Compression, lb <sub>f</sub> (kN)	10,000 (44)	10,000 (44)	11,000 (49)	11,000 (49)
Internal Rod Load - Single Acting:				
Tension, lb <sub>f</sub> (kN)	9000 (40)	9000 (40)	10,000 (44)	10,000 (44)

- a. For more information, refer to the Electronic Data, available in the Ariel Performance Program.
- b. Maximum allowable speed is the highest (potential) speed at which the compressor frame design will permit continuous operation. Compressor frame data plate "Frame Rated Speed (RPM)" is application specific, and may be lower than Maximum Allowable Speed. The lower of the Frame Rated Speed, lowest cylinder rated (RPM) or driver rated speeds is not to be exceeded.
- c. Minimum Speed is the minimum frame speed to provide adequate oil flow to the compressor bearings.
- d. Average piston speed as is based on the maximum allowable speed (RPM) of the frame. The cylinder data-plate rated speed (RPM) or frame rated speed may be less, resulting in a lower piston speed rating.
- e. Flow rate is based on the maximum allowable frame speed rating and 180°F (82°C) oil.

## Opposed Throw - Reciprocating Weight Balancing

Ariel recommends that the reciprocating weight differential between opposing throws be 1.0 pound (0.45 kg) or less for JGM:N:P:Q compressors. JGI compressors are not balanced.

If replacing any major reciprocating component, that is; a connecting rod assembly, piston, piston & rod assembly, crosshead-balance nuts or crosshead, weigh component parts on a calibrated scale to 0.1 pounds (0.05 kg) and compare to the Compressor Balancing Record sheet that comes in the parts manual with each compressor. If there are weight changes, recalculate opposing throw reciprocating weight differentials. If not within the recommended limit, new balance nuts and/or crossheads are to be selected to provide the least possible differential.

If it is desirable to exchange opposing throw compressor cylinder locations, all reciprocating components must be exchanged to the opposite throw, except the connecting rod assemblies. Check the Balancing Record sheet and recalculate reciprocating weight differential, with the connecting rod weights included. If not within the recommended limit, new crosshead-balance nuts are to be selected to provide the least possible differential.

If opposing throws can not be balanced within the recommended reciprocating weight differential limit, contact your packager and/or Ariel. When applying or re-applying a different cylinder to a throw, the opposing throw reciprocating weight differential must be re-calculated and new balance nuts or crossheads may be required. The force feed oil distribution system may also need to be resized.

Contact your Packager or the Ariel Response Center for detailed information, if reciprocating weights change and exceed the recommended reciprocating weight differential between opposing throws, when exchanging opposing throw compressor cylinder locations or when applying or re-applying a different cylinder to a throw. Refer to the last page of this manual for contact information

# Product Information and Safety Plates

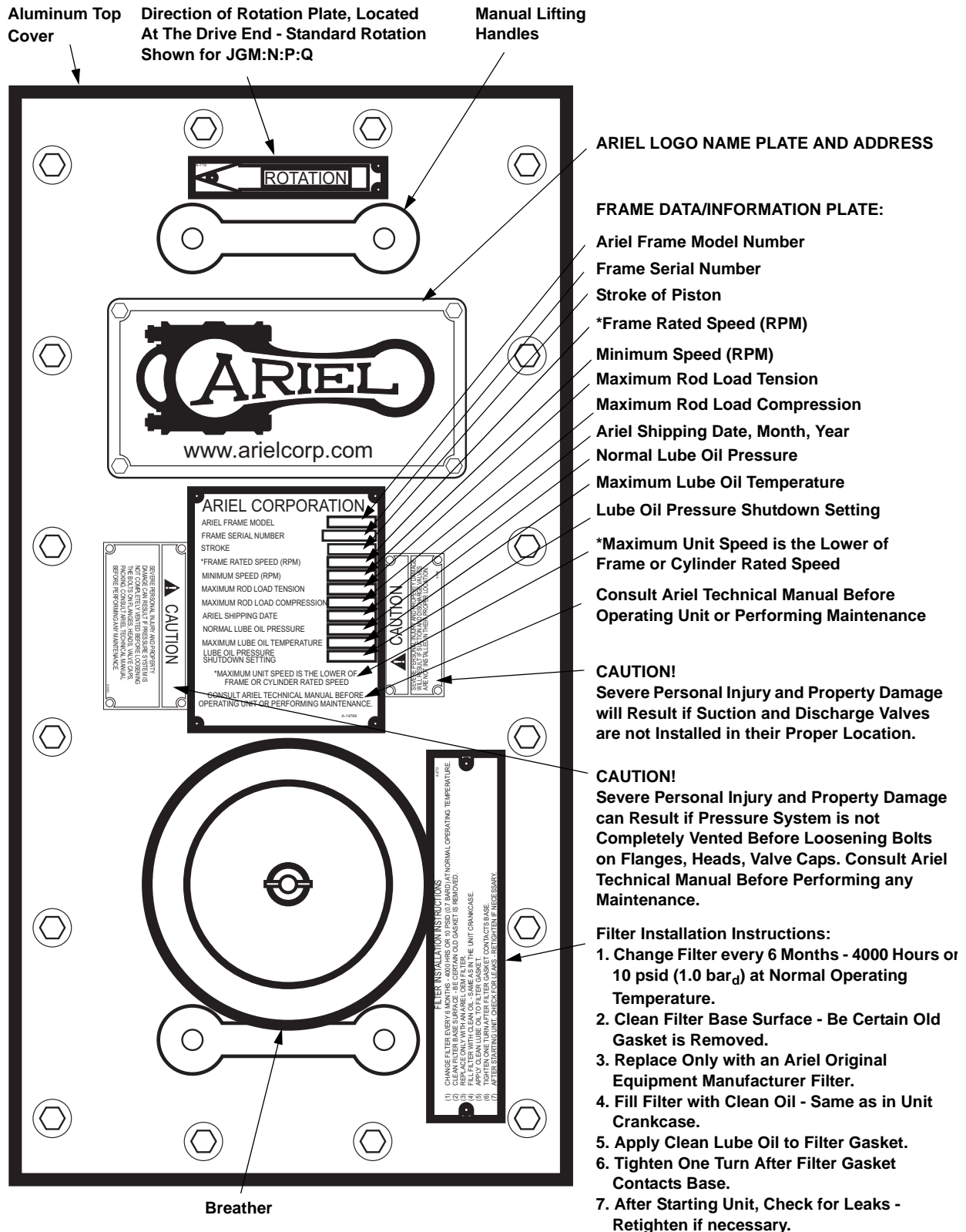


FIGURE 1-4 TOP COVER - TYPICAL JGM:N:P:Q

## Important Safety & Data Information

### CAUTION

SEVERE PERSONAL INJURY AND PROPERTY DAMAGE CAN RESULT IF PRESSURE SYSTEM IS NOT COMPLETELY VENTED BEFORE LOOSENING THE BOLTS ON FLANGES, HEADS, VALVE CAPS, OR PACKING. CONSULT ARIEL TECHNICAL MANUAL BEFORE PERFORMING ANY MAINTENANCE.

### CAUTION

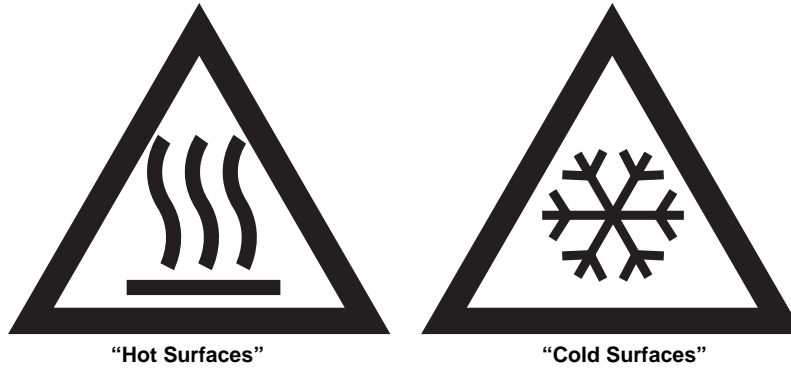
SEVERE PERSONAL INJURY AND PROPERTY DAMAGE WILL RESULT IF SUCTION AND DISCHARGE VALVES ARE NOT INSTALLED IN THEIR PROPER LOCATION.

### CAUTION

NOISE GENERATED BY RECIPROCATING MACHINERY CAN BE A SOURCE FOR HEARING INJURY. SEE PACKAGER'S INFORMATION FOR ANY SPECIFIC RECOMMENDATIONS. WEAR HEARING PROTECTION WHEN UNIT IS RUNNING.

### CAUTION

HOT (OR COLD) GAS TEMPERATURES ESPECIALLY THE CYLINDER DISCHARGE AREAS, 190°F (88°C) OIL AND HIGH FRICTION AREAS CAN BE A SOURCE FOR BURNS OR FROST BITE. WEAR PROPER INSULATION WHEN WORKING AROUND THESE AREAS. SHUT DOWN UNIT AND ALLOW TO COOL (OR WARM) BEFORE DOING MAINTENANCE IN THESE AREAS.



Where these CAUTION symbols appear on the compressor, the surfaces are hot or cold when compressor is operating and can cause injury if touched without proper insulated protective clothing. If servicing the compressor, allow these surfaces to cool or warm to safe temperatures or wear protective clothing before proceeding. When applied to compressor cylinders, the temperature CAUTION applies to all connected piping and equipment.

FIGURE 1-1 HOT & COLD SURFACES - CAUTION SYMBOLS

Lubricator Data Plate cycle time values (seconds) are at maximum rated speed. At reduced speeds, the cycle time will increase. See Section 4 for calculating increased cycle times for reduced speeds. If pump stroke/cycle time was properly adjusted at maximum rated speed, little or no adjustment should be required at reduced speeds.

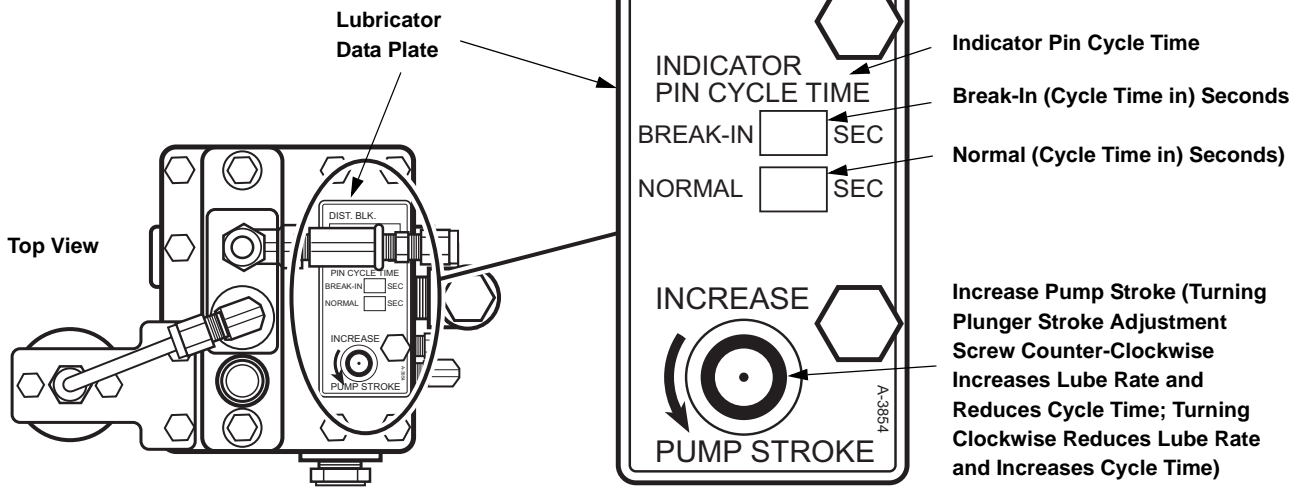


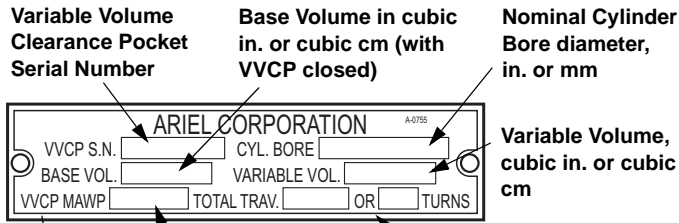
FIGURE 1-5 FORCE FEED LUBRICATOR DATA PLATE - TYPICAL

The Force Feed Lubricator provides oil to the piston rod packing and the compressor pistons. The Lubricator Data Plate provides cycle time values and directions for adjusting the pump stroke to control the flow rate of the lube oil and the cycle time. If this plate is missing, please contact Ariel Corporation, Mount Vernon, Ohio for a replacement and specific directions.

**NOTE: THE FORCE FEED LUBRICATOR BOX CONTAINS APPROXIMATELY 1/3 GALLON (1L) OF LUBRICANT. LUBE BOX OIL IS FOR LUBRICATING THE INTERNAL PARTS OF THE BOX, AND NOT A SOURCE OF OIL FOR THE FORCE FEED LUBE SYSTEM.**

**VVCP - Variable Volume Clearance Pocket Data Plate**

Customer work order number and hydrotest pressure stamped near VVCP plates on top of VVCP body.



VVCP Maximum Allowable Working Pressure (maximum relief valve setting), pounds per square inch gauge or bar<sub>g</sub>

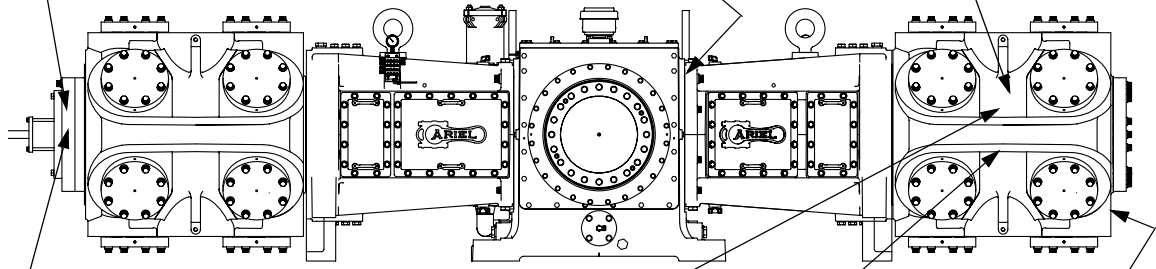
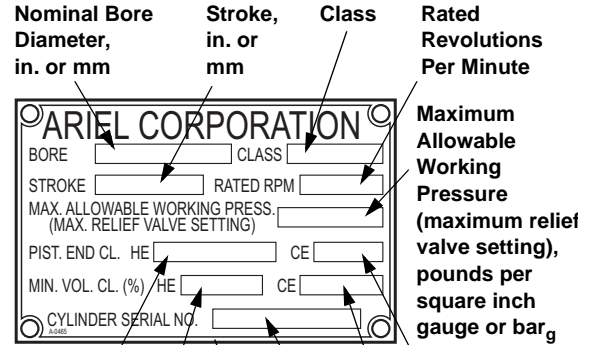
Total Travel in. or cm, or number of turns



Frame serial number is stamped on frame machined surface (above Mechanical Inspector's Plate - this plate is not provided if compressor was mechanically incomplete at factory testing) on drive end, throw #2 side.

**Cylinder Identification/Data Plate**

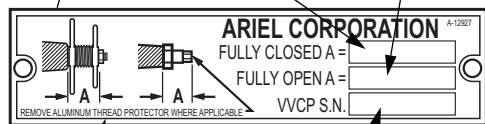
Cylinder Identification Plates appear on each cylinder. The serial number is also stamped on the end of each cylinder.



**VVCP Instruction Plate**

Fully Closed Dimension A, inches or cm

Fully Open Dimension A, inches or cm



"Suction" Valve Pocket Identification Plate



"Discharge" Valve Pocket Identification Plate

Serial number, MAWP, part number, work order number, hydrostatic test pressure, test date, and tester's personal stamp are stamped on the end of each cylinder.

**NOTE: USE CYLINDER AND FRAME SERIAL NUMBERS IN ALL CORRESPONDENCE**

**FIGURE 1-2 IDENTIFICATION PLATE LOCATIONS - COMPRESSOR DRIVE END VIEW**

If any plate is missing, please contact Ariel Corporation, Mount Vernon, Ohio for a replacement and specific directions.

# Clearances

**TABLE 1-3 CLEARANCES**

DESCRIPTION	CLEARANCE	
	in.	(mm)
Crankshaft Dust Seal (Feeler Gauge - Centered) <sup>a</sup>	0.008 to 0.010	(0.20 to 0.25)
Crankshaft Thrust (End) JGM:N:P:Q	0.0035 to 0.0110	(0.089 to 0.279)
Crankshaft Thrust (End) JGI	0.0090 to 0.0250	(0.229 to 0.635)
Crankshaft Journal Bearing (Jack) <sup>1</sup>	0.0005 to 0.0035	(0.013 to 0.089)
Crankshaft Pin to Connecting Rod Bearing (Jack) <sup>1</sup>	0.0015 to 0.0040	(0.038 to 0.102)
Connecting Rod Thrust (Side) JGM:N:P:Q	0.0070 to 0.0160	(0.178 to 0.406)
Connecting Rod Thrust (Side) JGI	0.0090 to 0.0150	(0.229 to 0.381)
Connecting Rod Bushing to Crosshead Pin	0.0014 to 0.0031	(0.036 to 0.079)
Crosshead Bushing to Crosshead Pin - JGN:Q	0.0014 to 0.0036	(0.036 to 0.091)
Crosshead (Bronze) to Crosshead Pin	0.0015 to 0.0025	(0.038 to 0.064)
Crosshead (Gray Iron) to Crosshead Pin - JGI:M:P	0.0015 to 0.0025	(0.038 to 0.064)
Crosshead (Babbitted Ductile Iron) to Guide <sup>b</sup> - JGN:Q	0.004 to 0.008	(0.10 to 0.20)
Crosshead (Babbitted Bronze) to Guide <sup>2</sup>	0.006 to 0.010	(0.15 to 0.25)
Crosshead (Gray Iron) to Guide <sup>2</sup> - JGI:M:P	0.006 to 0.010	(0.15 to 0.25)
Total Piston End Clearance - Double Acting <sup>c</sup>	0.090 to 0.145	(2.29 to 3.68)
Piston End Clearance - Crank End (Double Acting)	0.035	(0.89)
Piston End Clearance - Head End (Double Acting)	0.055 to 0.110	(1.40 to 2.79)
Total Piston End Clearance - Tandem <sup>3</sup>	0.090 to 0.180	(2.29 to 4.57)
Piston End Clearance - Crank End (Tandem)	0.035	(0.89)
Piston End Clearance - Head End (Tandem)	0.055 to 0.145	(1.40 to 3.68)
Fan Shaft Total Indicator reading (TIR) max.	0.010	(0.25)

a. Not applicable to JGI.

b. Crosshead guide to crosshead clearance at the top (at side, top and bottom ends for JGI) is to be checked by inserting a standard 0.500 inch (13 mm) wide feeler stock from one side edge of the crosshead across to the opposite side. This is to be done at both ends. The bottom clearance is to be checked with 0.0015 inch (0.038 mm) feeler stock at the 4 corners. If the feeler can be inserted more than 0.500 inches (13 mm), the assembly is not acceptable.

c. If total piston end clearance is not within table tolerance, crank end + head end as measured, contact Packager or Ariel.

**NOTE: MEASURED CLEARANCES WILL NOT NECESSARILY AGREE BECAUSE OF OIL FILMS, ASSEMBLY TOLERANCES, WEAR, ETC. PLASTIGAGES, SOLDER, ETC. ARE NOT TO BE USED.**

## Piston Ring and Packing Ring Side Clearance, Inches (mm)

The standard side clearance in inches (mm) for JG, M, P and SP class cylinders - piston rings and packing rings, when new, are as follows:

**TABLE 1-4 NEW CONVENTIONAL PISTON RING SIDE CLEARANCE, INCHES (mm)**

NOMINAL WIDTH	ACTUAL GROOVE WIDTH	TEFLON ONE-PIECE	BRONZE
3/16 (4.76)	0.187 to 0.189 (4.75 to 4.80)	0.005 to 0.009 (0.13 to 0.23)	0.004 to 0.008 (0.10 to 0.20)
1/4 (6.35)	0.250 to 0.252 (6.35 to 6.40)	0.005 to 0.009 (0.13 to 0.23)	0.004 to 0.008 (0.10 to 0.20)
3/8 (9.53)	0.375 to 0.377 (9.53 to 9.58)	0.007 to 0.011 (0.18 to 0.28)	0.004 to 0.008 (0.10 to 0.20)
3/4 (19.05)	0.750 to 0.752 (19.05 to 19.10)	0.014 to 0.019 (0.36 to 0.48)	0.006 to 0.010 (0.15 to 0.25)

**TABLE 1-5 NEW RIDER RING PISTON RING SIDE CLEARANCE, INCHES (mm)**

NOMINAL WIDTH	ACTUAL GROOVE WIDTH	TWO-PIECE
3/16 (4.76)	0.187 to 0.189 (4.75 to 4.80)	0.007 to 0.012 (0.18 to 0.30)
1/4 (6.35)	0.250 to 0.252 (6.35 to 6.40)	0.008 to 0.013 (0.20 to 0.33)
3/8 (9.53)	0.375 to 0.377 (9.53 to 9.58)	0.008 to 0.013 (0.20 to 0.33)
1/2 (12.70)	0.500 to 0.502 (12.70 to 12.75)	0.008 to 0.013 (0.20 to 0.33)
3/4 (19.05)	0.750 to 0.752 (19.05 to 19.10)	0.008 to 0.013 (0.20 to 0.33)

**TABLE 1-6 PACKING RING SIDE CLEARANCE, INCHES (mm)**

ACTUAL GROOVE WIDTH	1 - RING/GROOVE NON-METAL or CI	2 - RINGS GROOVE NON-METAL or CI	3 - RINGS/GROOVE NON-METAL or CI	BRONZE
0.375 to 0.377 (9.53 to 9.58)	0.011 to 0.014 (0.28 to 0.36)	0.011 to 0.015 (0.28 to 0.38)	N/A	0.006 to 0.008 (0.15 to 0.20)
0.447 to 0.449 (11.35 to 11.41)	N/A	N/A	0.013 to 0.018 (0.33 to 0.46)	
0.562 to 0.564 (14.28 to 14.33)	N/A	N/A	0.017 to 0.022 (0.43 to 0.56)	
0.936 to 0.938 (23.77 to 23.82)	N/A	Zero (0) <sup>a</sup>		N/A

a. Side loaded "AL" (5) ring type



**TABLE 1-7 PISTON TO BORE CLEARANCE AND CONVENTIONAL PISTON RING END GAP, IN. (mm) - M, P & SP CLASS CYLINDERS**

BORE DIAMETER <sup>a</sup>	PISTON TO BORE CLEARANCE	PISTON RING END GAP - TFE	
		NEW	MAXIMUM
2.0625 (52)	0.007 to 0.011 (0.18 to 0.28)	0.025 to 0.030 (0.64 to 0.76)	0.120 (3.05)
2.25 (57)	0.007 to 0.011 (0.18 to 0.28)	0.027 to 0.032 (0.69 to 0.81)	0.128 (3.18)
2.5 (64)	0.007 to 0.011 (0.18 to 0.28)	0.030 to 0.036 (0.76 to 0.91)	0.144 (3.66)
2.75 (70)	0.007 to 0.011 (0.18 to 0.28)	0.033 to 0.040 (0.84 to 1.02)	0.160 (3.71)
3 (76)	0.007 to 0.011 (0.18 to 0.28)	0.036 to 0.044 (0.91 to 1.12)	0.176 (4.47)
3.25 (83)	0.009 to 0.013 (0.23 to 0.33)	0.039 to 0.047 (0.99 to 1.19)	0.188 (4.76)
3.5 (89)	0.009 to 0.013 (0.23 to 0.33)	0.042 to 0.052 (1.07 to 1.30)	0.208 (5.28)
3.75 (95)	0.010 to 0.014 (0.25 to 0.36)	0.046 to 0.056 (0.17 to 1.42)	0.224 (5.69)
3.875 (98)	0.010 to 0.014 (0.25 to 0.36)	0.047 to 0.057 (0.19 to 1.45)	0.228 (5.79)
4.125 (105)	0.010 to 0.014 (0.25 to 0.36)	0.049 to 0.060 (1.24 to 1.52)	0.240 (6.10)
4.375 (111)	0.011 to 0.015 (0.28 to 0.38)	0.052 to 0.064 (1.32 to 1.63)	0.255 (6.48)
4.75 (121)	0.012 to 0.017 (0.30 to 0.43)	0.057 to 0.077 (1.45 to 1.96)	0.308 (7.82)
5.125 (130)	0.012 to 0.017 (0.30 to 0.43)	0.061 to 0.081 (1.55 to 2.06)	0.324 (8.23)
5.5 (140)	0.013 to 0.018 (0.33 to 0.46)	0.065 to 0.085 (1.65 to 2.16)	0.340 (8.64)
5.75 (146)	0.013 to 0.018 (0.33 to 0.46)	0.068 to 0.088 (1.73 to 2.24)	0.352 (8.94)
6.125 (156)	0.014 to 0.020 (0.36 to 0.51)	0.073 to 0.093 (1.85 to 2.36)	0.372 (9.45)
6.5 (165)	0.014 to 0.020 (0.36 to 0.51)	0.077 to 0.097 (1.96 to 2.46)	0.388 (9.86)
7.5 (191)	0.016 to 0.022 (0.41 to 0.56)	0.089 to 0.109 (2.26 to 2.77)	0.430 (10.92)
8 (203)	0.016 to 0.022 (0.41 to 0.56)	0.095 to 0.115 (2.41 to 2.87)	0.460 (11.68)
8.5 (216)	0.017 to 0.023 (0.43 to 0.58)	0.102 to 0.122 (2.59 to 3.10)	0.488 (12.40)
8.875 (225)	0.018 to 0.024 (0.46 to 0.61)	0.106 to 0.126 (2.69 to 3.20)	0.504 (12.80)
10.5 (267)	0.021 to 0.027 (0.53 to 0.69)	0.125 to 0.145 (3.18 to 3.68)	0.580 (14.73)
11 (279)	0.022 to 0.028 (0.56 to 0.71)	0.131 to 0.151 (3.33 to 3.84)	0.604 (15.34)
13 (330)	0.026 to 0.032 (0.66 to 0.81)	0.155 to 0.175 (3.94 to 4.45)	0.700 (17.78)
13.5 (343)	0.027 to 0.033 (0.69 to 0.84)	0.162 to 0.182 (4.12 to 4.63)	0.728 (18.49)

a. Conventional piston rings are standard for all M, P and SP Class Cylinders, except for 1-3/4M-FS Class Cylinder with bore diameters of 1.625" (41mm) and 1.75" (44) where piston/rider rings are standard. Piston/rider rings are optional for all other M, P and SP Class Cylinders.

**TABLE 1-8 PISTON TO BORE CLEARANCE AND PISTON/RIDER RING END GAP, IN. (mm) - M, P & SP CLASS CYLINDERS**

BORE DIAMETER <sup>a</sup>	PISTON TO BORE CLEARANCE	PISTON/RIDER RING END GAP	
		NEW	MAXIMUM
1.625 (41)	0.090 to 0.096 (2.29 to 2.44)		
1.75 (44)	0.090 to 0.096 (2.29 to 2.44)	0.016 to 0.032 (0.41 to 0.81)	0.128 (3.25)
2.0625 (52)	0.090 to 0.096 (2.29 to 2.44)	0.020 to 0.036 (0.51 to 0.91)	0.144 (3.66)
2.25 (57)	0.090 to 0.096 (2.29 to 2.44)		
2.5 (64)	0.090 to 0.096 (2.29 to 2.44)	0.044 to 0.060 (1.12 to 1.52)	0.240 (6.10)
2.75 (70)	0.090 to 0.096 (2.29 to 2.44)	0.044 to 0.060 (1.12 to 1.52)	0.240 (6.10)
3 (76)	0.090 to 0.096 (2.29 to 2.44)	0.044 to 0.060 (1.12 to 1.52)	0.240 (6.10)
3.25 (83)	0.090 to 0.096 (2.29 to 2.44)	0.044 to 0.060 (1.12 to 1.52)	0.240 (6.10)
3.5 (89)	0.090 to 0.096 (2.29 to 2.44)	0.044 to 0.060 (1.12 to 1.52)	0.240 (6.10)
3.75 (95)	0.090 to 0.096 (2.29 to 2.44)	0.044 to 0.060 (1.12 to 1.52)	0.240 (6.10)
3.875 (98)	0.090 to 0.096 (2.29 to 2.44)	0.045 to 0.061 (1.14 to 1.55)	0.244 (6.20)
4.125 (105)	0.090 to 0.096 (2.29 to 2.44)	0.049 to 0.065 (1.24 to 1.65)	0.260 (6.60)
4.375 (111)	0.090 to 0.096 (2.29 to 2.44)	0.052 to 0.068 (1.32 to 1.73)	0.272 (6.91)
4.75 (121)	0.090 to 0.096 (2.29 to 2.44)	0.057 to 0.073 (1.45 to 1.85)	0.292 (7.42)
5.125 (130)	0.090 to 0.096 (2.29 to 2.44)	0.062 to 0.078 (1.57 to 1.98)	0.312 (7.93)
5.5 (140)	0.090 to 0.096 (2.29 to 2.44)	0.068 to 0.084 (1.73 to 2.13)	0.336 (8.53)
5.75 (146)	0.090 to 0.096 (2.29 to 2.44)	0.071 to 0.087 (1.80 to 2.21)	0.348 (8.84)
6.125 (156)	0.090 to 0.096 (2.29 to 2.44)	0.069 to 0.099 (1.75 to 2.51)	0.396 (10.06)
6.5 (165)	0.090 to 0.096 (2.29 to 2.44)	0.074 to 0.104 (1.88 to 2.64)	0.416 (10.57)
7.5 (191)	0.090 to 0.096 (2.29 to 2.44)	footnote <sup>b</sup>	footnote <sup>2</sup>
8 (203)	0.090 to 0.096 (2.29 to 2.44)	footnote <sup>2</sup>	footnote <sup>2</sup>
8.5 (216)	0.090 to 0.096 (2.29 to 2.44)	0.114 to 0.144 (2.90 to 3.66)	0.576 (14.63)
8.875 (225)	0.090 to 0.096 (2.29 to 2.44)	0.120 to 0.150 (3.05 to 3.81)	0.600 (15.24)
10.5 (267)	0.090 to 0.096 (2.29 to 2.44)	0.144 to 0.174 (3.66 to 4.42)	0.696 (17.68)
11 (279)	0.090 to 0.096 (2.29 to 2.44)	0.152 to 0.182 (3.86 to 4.62)	0.728 (18.49)
13 (330)	0.090 to 0.096 (2.29 to 2.44)	0.182 to 0.212 (4.62 to 5.39)	0.848 (21.54)
13.5 (343)	0.090 to 0.096 (2.29 to 2.44)	0.190 to 0.220 (4.83 to 5.59)	0.880 (22.35)

a. Conventional piston rings are standard for all M, P and SP Class Cylinders, except for 1-3/4M-FS with bore diameters of 1.625" (41mm) and 1.75" (44) where piston/rider rings are standard. Piston/rider rings are optional for all other M, P and SP Class Cylinders, except for 1-3/4SG-FS-HE which uses conventional rings and wear band.

b. 8M x 3-1/2" (88.9 mm) stroke & 8SP-HE class cylinders, w/ 7.5" (191) bore: end gap, new is 0.099" to 0.129" (2.51 to 3.53), maximum is 0.516" (13.11). 8M x 3" (76.2) stroke, w/ 7.5" (191) bore: new 0.088" to 0.118" (2.24 to 3.00), maximum 0.472" (11.99). 8M x 3-1/2" (88.9) & 8SP-HE, w/ 8" (203) bore: new 0.106" to 0.136" (2.69 to 3.43), maximum 0.544" (14.07). 8M x 3" (76.2) w/ 8" (203) bore: new 0.095" to 0.125" (2.41 to 3.18), maximum 0.500" (12.70).

**TABLE 1-9 PISTON TO BORE CLEARANCE AND CONVENTIONAL PISTON RING END GAP, IN. (mm) - JG & SG CLASS CYLINDERS**

BORE DIAMETER <sup>a</sup>	PISTON TO BORE CLEARANCE	PISTON RING END GAP - NON-METALLIC	
		New	Maximum
1.25 (32) <sup>b</sup>	0.025 to 0.033 (0.64 to 0.84)	0.018 to 0.028 (0.46 to 0.71)	0.112 (2.85)
1.5 (38) <sup>2</sup>	0.030 to 0.038 (0.76 to 0.97)	0.021 to 0.031 (0.51 to 0.79)	0.124 (3.15)
1.625 (41) <sup>2</sup>	0.030 to 0.038 (0.76 to 0.97)	0.023 to 0.033 (0.58 to 0.84)	0.132 (3.35)
1.75 (44) <sup>2</sup>	0.030 to 0.038 (0.76 to 0.97)	0.025 to 0.035 (0.64 to 0.89)	0.140 (3.55)
2.75 (70)	0.009 to 0.014 (0.23 to 0.36)	0.027 to 0.033 (0.69 to 0.81)	0.132 (3.35)
3 (76)	0.009 to 0.014 (0.23 to 0.36)	0.030 to 0.036 (0.76 to 0.91)	0.144 (3.66)
3.375 (86)	0.010 to 0.015 (0.25 to 0.38)	0.034 to 0.041 (0.88 to 1.04)	0.164 (4.17)
3.625 (92)	0.010 to 0.015 (0.25 to 0.38)	0.036 to 0.044 (0.91 to 1.12)	0.176 (4.47)
3.875 (98)	0.011 to 0.016 (0.28 to 0.41)	0.039 to 0.047 (0.99 to 1.19)	0.188 (4.78)
4.125 (105)	0.011 to 0.016 (0.28 to 0.41)	0.041 to 0.050 (1.04 to 1.27)	0.200 (5.08)
4.75 (121)	0.012 to 0.018 (0.30 to 0.46)	0.057 to 0.077 (1.45 to 1.96)	0.308 (7.82)
5.125 (130)	0.012 to 0.018 (0.30 to 0.46)	0.061 to 0.081 (1.55 to 2.06)	0.324 (8.23)
6.125 (156)	0.013 to 0.019 (0.33 to 0.48)	0.073 to 0.093 (1.85 to 2.36)	0.372 (9.45)
6.5 (165)	0.014 to 0.020 (0.36 to 0.51)	0.077 to 0.097 (1.96 to 2.46)	0.388 (9.86)
7.125 (181)	0.015 to 0.021 (0.38 to 0.53)	0.085 to 0.105 (2.16 to 2.67)	0.409 (10.39)
7.5 (191)	0.015 to 0.021 (0.38 to 0.53)	0.089 to 0.109 (2.26 to 2.77)	0.430 (10.92)
8.5 (216)	0.017 to 0.023 (0.43 to 0.58)	0.102 to 0.122 (2.59 to 3.10)	0.488 (12.40)
8.875 (225)	0.018 to 0.024 (0.46 to 0.61)	0.106 to 0.126 (2.69 to 3.20)	0.504 (12.80)

a. Conventional piston rings are standard for JG Class Cylinders, except 2-1/2JG-FS-HE Class cylinders with bore diameters of 2.25" (57mm) & 2.5" (64); 3JG-CE, 2.75" (70) & 3" (76); and 3-5/8JG-CE, 3.375" (86) & 3.625" (92), which use piston/rider rings. Piston/rider rings are optional for other JG Cylinders, except for 1-3/4JG-FS-HE which uses conventional rings and wear band.

b. These sizes use conventional piston rings and wear band, see Table 1-10 for wear band values.

**TABLE 1-10 WEAR BAND END GAP & RADIAL PROJECTION (NEW) - 1-3/4JG-FS-HE & 1-3/4SG-FS-HE CLASS, IN. (mm)**

BORE DIAMETER	END GAP MINIMUM	RADIAL PROJECTION	SIDE CLEARANCE
1.25 (32)	0.049 (1.24)	0.005 to 0.012 (0.13 to 0.30)	0.010 to 0.014 (0.25 to 0.36)
1.5 (38)	0.049 (1.24)	0.0075 to 0.0145 (0.19 to 0.37)	0.010 to 0.014 (0.25 to 0.36)
1.625 (41)	0.052 (1.32)	0.0075 to 0.0145 (0.19 to 0.37)	0.010 to 0.014 (0.25 to 0.36)
1.75 (44)	0.058 (1.47)	0.0075 to 0.0145 (0.19 to 0.37)	0.010 to 0.014 (0.25 to 0.36)

**TABLE 1-11 PISTON TO BORE CLEARANCE AND PISTON/RIDER RING END GAP, IN. (mm) - JG & SG CLASS CYLINDERS**

BORE DIAMETER <sup>a</sup>	PISTON TO BORE CLEARANCE	PISTON/RIDER RING END GAP	
		New	Maximum
2.25 (57)	0.090 to 0.096 (2.29 to 2.44)	0.023 to 0.039 (0.58 to 0.99)	0.156 (3.96)
2.5 (64)	0.090 to 0.096 (2.29 to 2.44)	0.030 to 0.046 (0.76 to 1.17)	0.184 (4.67)
2.75 (70)	0.090 to 0.096 (2.29 to 2.44)	0.044 to 0.060 (1.12 to 1.52)	0.240 (6.10)
3 (76)	0.090 to 0.096 (2.29 to 2.44)	0.044 to 0.060 (1.12 to 1.52)	0.240 (6.10)
3.375 (86)	0.090 to 0.096 (2.29 to 2.44)	0.044 to 0.060 (1.12 to 1.52)	0.240 (6.10)
3.625 (92)	0.090 to 0.096 (2.29 to 2.44)	0.047 to 0.063 (1.19 to 1.60)	0.252 (6.40)
3.875 (98)	0.090 to 0.096 (2.29 to 2.44)	0.051 to 0.067 (1.30 to 1.70)	0.268 (6.81)
4.125 (105)	0.090 to 0.096 (2.29 to 2.44)	0.055 to 0.071 (1.40 to 1.80)	0.284 (7.21)
4.75 (121)	0.090 to 0.096 (2.29 to 2.44)	0.057 to 0.073 (1.45 to 1.85)	0.292 (7.42)
5.125 (130)	0.090 to 0.096 (2.29 to 2.44)	0.062 to 0.078 (1.57 to 1.98)	0.312 (7.93)
6.125 (156)	0.090 to 0.096 (2.29 to 2.44)	0.069 to 0.099 (1.75 to 2.51)	0.396 (10.06)
6.5 (165)	0.090 to 0.096 (2.29 to 2.44)	0.074 to 0.104 (1.88 to 2.64)	0.416 (10.57)
7.125 (181)	0.090 to 0.096 (2.29 to 2.44)	0.083 to 0.113 (2.11 to 2.87)	0.452 (11.48)
7.5 (191)	0.090 to 0.096 (2.29 to 2.44)	0.088 to 0.118 (2.24 to 3.00)	0.472 (11.99)
8.5 (216)	0.090 to 0.096 (2.29 to 2.44)	0.114 to 0.144 (2.90 to 3.66)	0.576 (14.63)
8.875 (225)	0.090 to 0.096 (2.29 to 2.44)	0.120 to 0.150 (3.05 to 3.81)	0.600 (15.24)

a. Conventional piston rings are standard for JG Class Cylinders, except 2-1/2JG-FS-HE Class cylinders with bore diameters of 2.25" (57mm) & 2.5" (64); 3JG-CE, 2.75" (70) & 3" (76); and 3-5/8JG-CE, 3.375" (86) & 3.625" (92), which use piston/rider rings. Piston/rider rings are optional for other JG Cylinders, except for 1-3/4JG-FS-HE, which uses conventional rings and wear band.

## Fastener Tightening Torque

Listed in the following tables are fastener tightening torque values required for proper assembly of Ariel JGI, JGM, JGN, JGP and JGQ compressors. Refer to the section concerning a subject component for detailed assembly procedures.

Threads are to be clean and free of burrs.

Torque values are based on the use of petroleum type lubricants on both the threads and seating surfaces. Use lubricating oil or Lubriplate 630, except for compressor piston rods, crosshead-balance nuts and piston-nuts; and stainless steel fasteners which use Never-Seez, Regular Grade (by Bostik, available from industrial suppliers, such as [www.neverseezproducts.com](http://www.neverseezproducts.com)), and except where Loctite is specified. Molybdenum disulfide lubricants and Never-Seez are not otherwise to be used for fastener lubrication unless specified, or excessive stresses can result with the listed values. When anti-seize lubricants are

**FOR MODELS: JGI, JGM, JGN, JGP AND JGQ SECTION 1 - DESIGN SPECIFICATIONS & DATA**

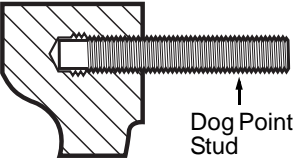
required, use very sparingly as excessive amounts will result in oil analysis indication contamination and unnecessarily increase maintenance costs.

For latest available torque values, see ER-63 at [www.arielcorp.com](http://www.arielcorp.com).

**TABLE 1-12 FASTENER TIGHTENING VALUES**

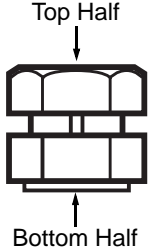
<b>FASTENER</b>	<b>NOMINAL SIZE, INCH - TPI</b>	<b>TYPE</b>	<b>TORQUE, LB-FT (N-m)</b>
Main Bearing Cap - Cap Screw	1/2 - 13	12 Point - Grade 8	58 (79)
JGI Bearing Carrier to Frame - Cap Screw	1/2 - 13	12 Point - Grade 8	44 (60)
Connecting Rod Cap - Cap Screw	1/2 - 13	12 Point - Grade 8/ Socket Head	58 (79)
	1/2 - 20		67 (91)
Crosshead Pin Through Bolt	3/8 - 24	Hex - Lock Nut	25 (34)
Frame to Cylinder - Cap Screw	1/2 - 13	12 Point - Grade 8	48 (65)
Crosshead Guide to Support - Cap Screw	5/8 - 11	Hex - Grade 8 or 9	90 (120)
Eccentric Vernier Cap - Cap Screw	5/16 - 18	Hex - Grade 8	Hand-wrench Tight
Idler Sprocket Through Bolt - Lock Nut	1/2 - 20	Hex - Lock Nut	41 (55)
Rod Packing - Cap Screw	1/2 - 13	12 Point - Grade 8	35 (48)
Piston Nut <sup>a</sup>	7/8 - 12	Ariel Design	222 (300)
Crosshead-Balance Nut	1 - 12	Ariel Design	Slugged <sup>b</sup>
Piston Rod Oil Slinger - Lock Nut	1/4 - 28	lock Nut	96 lb-in. (11)
Rupture Disk - Blow-Out Fitting Cap	1/4 Nom. Tube	Hex - Tube Fitting	40 lb-in. (4.4)
Hold Down - Stud-Nut	5/8 - 11	Hex Stud-Nut	100 <sup>c</sup> (130)
	3/4 - 10		175 <sup>3</sup> (235)
Valve Cap; Cylinder Head; Gas Passage Cap; Unloader; Ariel Supplied Companion Flanges - Cap Screw	3/8 - 16	Hex - Grade 8 or 9 or 12Point - Grade B7M or 8	193 lb-in. (22)
	7/16 - 14		26 (35)
	1/2 - 13		40 (54)
	9/16 - 12		57 (77)
	5/8 - 11		79 (105)
	5/8 - 18		92 (125)
	3/4 - 10		140 (190)
	3/4 - 16		160 (215)
	7/8 - 9		230 (310)
	7/8 - 14		260 (350)
	1 - 8		345 (465)
1 - 16	395 (535)		

**TABLE 1-12 FASTENER TIGHTENING VALUES**

FASTENER	NOMINAL SIZE, INCH - TPI	TYPE	TORQUE, LB-FT (N·m)
Tandem Cylinder to Cylinder - Cap Screw <sup>c</sup>	1/2 - 13	Hex - Grade 8 or 9 or 12 Point - Grade 8	44 (60)
	5/8 - 11		88 (120)
	3/4 - 10		160 (215)
	3/4 - 16		180 (245)
Fanshaft to Crankshaft - Central Stud	3/4 - 16	Ariel Design	250 (340)
Seating Studs in Cylinder  	3/8 - 16	Dog Point	107 lb-in. (12)
	7/16 - 14		172 lb-in. (19)
	1/2 - 13		22 (30)
	9/16 - 12		32 (43)
	5/8 - 11		44 (60)
	5/8 - 18		51 (70)
	3/4 - 10		79 (105)
	3/4 - 16		90 (120)
	7/8 - 9		130 (170)
	7/8 - 14		145 (195)
	1 & Larger		200 (270)
Spacer Bar	5/8 - 11	Cap Screw Gr. 8	92 (125)
Distribution Block Tie Rod - Nut	1/4 - 28	Hex	68 lb-in. (7.7)
Distribution Block Divider Valve - Screw	1/4 - 28	Socket Head	75 lb-in. (8.5)
Force Feed Lubricator	1 - 14	Hex Jam Nut	75 (100)
Grade 5 - Hex Cap Screw	All	Hex - Grade 5	Hand-wrench Tight

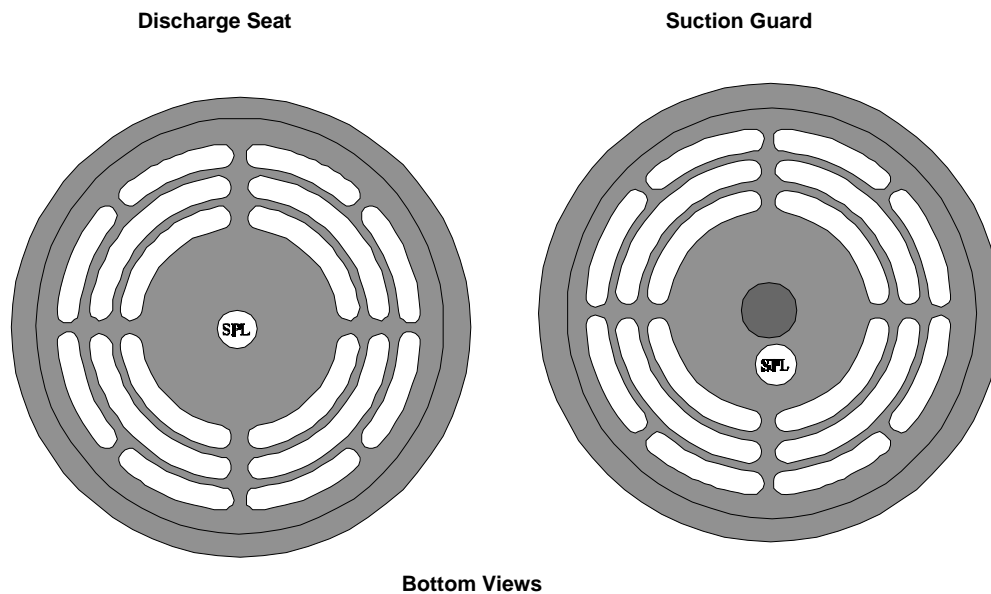
- a. Tighten, loosen, and re-tighten the Piston Nut to ensure proper tightening.
- b. Use the Ariel Tried and True Slugging Method, see Section 5.
- c. Minimum torque for recommended, 5/8" - 11TPI for JGM, JGN, JGP, JGQ and 3/4"-10TPI for JGI, hold down stud size to provide stress in stud of 55,000 psi (380 MPa). Stud must have an ultimate strength of 100,000 psi (690 MPa) or greater. If greater, increase torque to stress stud to about 55% of ultimate strength of stud material, as specified by packager.

**TABLE 1-13 HOERBIGER VALVE ASSEMBLY FASTENERS - TIGHTENING VALUES**

FASTENER	NOMINAL INCH - TPI	TYPE	TORQUE, LB-FT (N·m)	
<p>Center Cap Screw</p> <p>12-Point Cap Screw threads for Valve Assemblies <u>not</u> marked SPL (<u>without</u> Spirallock Threads), must be cleaned with Loctite Safety solvent and locked with one to two drops of Loctite #272. Cap Screws for Assemblies marked SPL (see Figure 1-6 on page 19) are lubricated, both threads and seating surfaces, with a petroleum type lubricant only.</p>	5/16 - 24	12 Point- Steel Grade 5	144 lb-in. (16)	
	3/8 - 24	Material Parts: SPL3 & 4	21 (28)	
	7/16 - 20		30 (41)	
	5/16 - 24	Material Parts: SPL5	12 Point- Steel Grade 5	18 (24)
	3/8 - 24		32 (43)	
	7/16 - 20		50 (68)	
	5/16 - 24	12 Point - Stainless Steel Grade B8M Material Parts: SPL6	12 Point - Steel Grade 8	120 lb-in. (14)
	3/8 - 24			192 lb-in. (22)
	7/16 - 20			24 (33)
	5/16 - 24	Out of Production	Out of Production	18 (24)
	3/8 - 24			32 (43)
	7/16 - 20			50 (68)
<p>Center Stud - Drake Lock Nut</p> <div style="text-align: center;">  </div> <p>*Use 29 lb x ft (39 N·m) for 1/2 - 20 Bottom Half - Drake Lock Nut with non-metallic Plates in Liftwasher Type Valves.</p>	1/4 - 28	Bottom Half	103 lb x in. (11.6)	
		Top Half	66 lb x in. (7.5)	
	5/16 - 24	Bottom Half	120 lb x in. (13.6)	
		Top Half	66 lb x in. (7.5)	
	3/8 - 24	Bottom Half	192 lb x in. (21.7)	
		Top Half	96 lb x in. (10.8)	
	1/2 - 20	Bottom Half	*36 (*49)	
		Top Half	20 (27)	
	5/8 - 18	Bottom Half	73 (99)	
		Top Half	40 (54)	
	3/4 - 16	Bottom Half	130 (176)	
		Top Half	70 (95)	

**TABLE 1-13 HOERBIGER VALVE ASSEMBLY FASTENERS - TIGHTENING VALUES**

FASTENER	NOMINAL INCH - TPI	TYPE	TORQUE, LB-FT (N·m)
Peripheral Cap Screws	10 - 32	Hex Socket Head	25 lb x in. (2.8)
	12 - 28		43 lb x in. (4.9)
	1/4 - 20		110 lb x in. (12.4)
	5/16 - 18		176 lb x in. (19.9)
	3/8 - 16		21 (28)



**FIGURE 1-6 SPIRALOCK THREADED VALVE ASSEMBLY - MARKED SPL**

## Tightening Torque Procedures

Listed below are some procedures which make fastener tightening more accurate and will help to be sure that the proper torque is being applied.

1. Be sure that the torque wrench is properly calibrated and used by qualified personnel to achieve the required fastener tightening torque for all critical parts. The exception is the crosshead-balance lock nut which may be tightened using the Ariel tried and true slugging method.
2. Always check to determine over what range the torque wrench is accurate, since



most torque wrenches are not accurate over their entire range.

3. Tighten all multi-bolt assemblies in steps (need not apply to Grade 5 cap screws). Tighten each cap screw until snug using an alternating (criss-cross) pattern. Next, tighten each cap screw to 25 percent of full torque, moving across from cap screw to cap screw, in an alternating (criss-cross) pattern. Repeat this step for 50, 75, and 100 percent of full torque. For main bearing and connecting rod bolts repeat the 100 percent step to be sure that all fasteners are properly torqued.
4. Always apply a steady slow force to a torque wrench, do not jerk it. When a torque wrench is jerked the amount of torque applied can be as much as one and a half times the amount set on the wrench. For example, if a wrench is set at 80 lb<sub>f</sub>-ft (108 N·m) but is jerked, 120 lb<sub>f</sub>-ft (163 N·m) torque can be applied.
5. Always do the final tightening with a torque wrench. Do not tighten the fastener with a ratchet or impact wrench and then “check” the torque with a torque wrench.
6. Do not double tap a torque wrench. Rapidly double tapping a torque wrench will make the torque on the bolt more than what is set by a significant amount.
7. When checking a tightened fastener torque, set torque wrench to proper required torque value and slowly apply a steady force until the click is felt.
8. Always reset the torque wrench to its lowest setting when the job is complete. If the torque wrench is left in a high setting the spring in it is stressed and will become inaccurate with time. If the torque wrench is put back to its lowest setting the spring will relax and retain its accuracy.
9. Do not use a torque wrench to break fasteners loose as it may overload the torque wrench and/or cause loss of calibration.
10. For applications requiring the use of a boxed end or crowsfoot adapter with a torque wrench to reach not readily accessible fasteners, the torque wrench setting will not be the actual torque applied to the fastener. The exception is when the adapter is 90 degrees to the torque wrench. The torque will be the same as on the wrench scale.
11. The ratio of actual torque at the fastener with that on the wrench scale is a function of the adapter's length and its position in relation to the torque wrench beam and the location on that at which the force is applied, see figure.

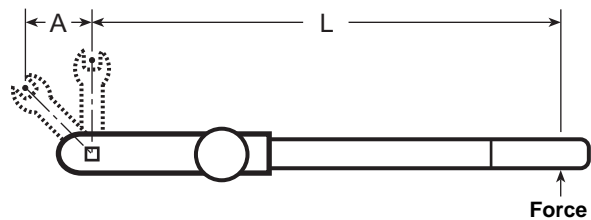


FIGURE 1-3 TORQUE WRENCH WITH ANGLED ADAPTER

$$T_w = T_a \left( \frac{L}{L + A} \right)$$

$T_w$  = Torque wrench setting, lb<sub>f</sub>-ft or N·m

$T_a$  = Torque required at fastener, lb<sub>f</sub>-ft or N·m

$L$  = Length of wrench, ft or m (from square drive end to center point of force on handle)

$A$  = Length of adapter, ft or m (measured through end of adapter on a line parallel to the center line of the wrench)

12. When studs are specified for cylinder applications, tighten stud-nuts to the same

values as cap screws in similar applications.

13. Pipe threads and main cap plugs are to be installed using Loctite 565 Thread Sealant. Synthetic oils may require Loctite 545 and Loctite Activator 7649 (N).

These are general guidelines to assist in the proper use of torque wrenches. Consult with your torque wrench dealer for more detailed information.

## Ariel Bolting

Bolting has been selected that meet Ariel's strength, elongation, sealing, and locking requirements. Proper bolting must be used and tightened to the values listed in Table 1-12 on page 1-16. Figure 1-4 is provided to assist in the identification of bolts used in an Ariel compressor.

Connecting rod, valve cap and suction/discharge nozzle - Ariel supplied speciality companion flange - bolting is designed to resist fatigue and cannot be replaced with standard cap screws. If attempting to replace other bolting with standard cap screws and there is any question, contact your packager or Ariel. Ariel supplied replacement bolting is recommended.

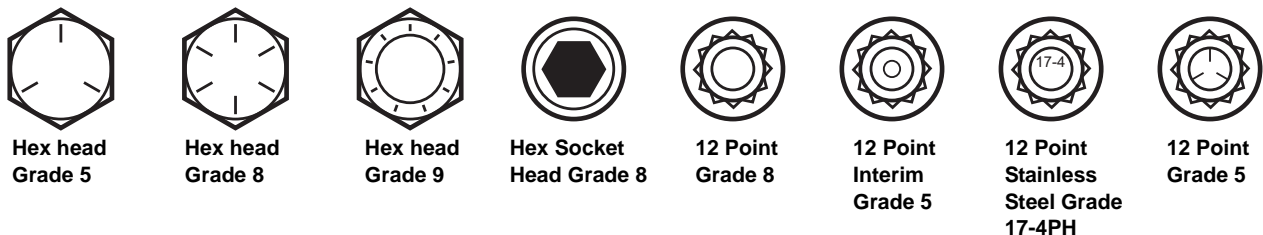


FIGURE 1-4 BOLT IDENTIFICATION

**CAUTION: WHEN RE-ASSEMBLING OR REPLACING BOLTING, SEE THE PARTS LIST TO DETERMINE THE PROPER FASTENER GRADE AND PART NUMBER. DO NOT USE A LESSER OR GREATER MATERIAL GRADE. ALL SPECIAL FASTENERS AND ALL BOLTING THAT HAS BEEN MADE TO REDUCE THE BODY DIAMETER FOR FATIGUE RESISTANCE, MUST BE REPLACED WITH ARIEL PARTS.**

## Zone 1 Environment

A Zone 1 environment requires the installation of proper intrinsically safe or equivalent protection to fulfill the electrical requirements, where applicable.

**NOTES:**

## SECTION 2 -INSTALLATION

The installation of the compressor with the associated driver and piping, is to be done with care and precision. This section addresses some of the more critical installation considerations and requirements, but does not attempt to address all of the concerns that can arise.

### The Skid or Package

Manufacture and install the skid or package in conformance to Ariel Packager Standards.

### Lifting the Compressor

Determine the weight of the compressor, prior to lifting. For an accurate value, see the **Ariel Performance Program** to determine frame and cylinder weights or for an approximate weight of the compressor with cylinders see Technical Manual Section 1, Frame Specifications tables. Also account for any extra weight such as a flywheel, etc. Spreader bars should be used to provide for a more vertical pull on the eyebolts or lifting lugs. Be sure that the eyebolts or lifting lugs, lifting tackle, spreader bars and crane capacity are adequate and properly rigged for the load. Keep the compressor level when lifting and setting. Heavier cylinders and/or blank throws can significantly affect the center of gravity.

Do not attempt lifting by hooking to a compressor when the compressor is attached to the skid, driver or piping. If you are not experienced in lifting large compressors, the use of qualified professional riggers/movers is recommended.

On compressor frames designed for lifting lugs, install the lugs (4) with the proper Grade 8 cap screws and tighten to the torque value given in the Technical Manual Section 1 or the tool box torque chart (the ER-63 chart is also available electronically at the Ariel web site: [www.arielcorp.com](http://www.arielcorp.com)), for lifting the compressor. If lifting lugs are already installed, recheck fastener tightening torque. JGZ:U/4, KBB:V/4 and all 6-throw compressors have lifting lugs.

When lifting a compressor not designed with lifting lugs, lift by the eyebolts installed by Ariel at the crosshead guides. Eyebolts installed in the crosshead guides by the Ariel Shop are locked with Loctite to help prevent them from turning. Inspect eyebolts to be sure they are free of any visual defects, such as bending, that could affect serviceability. Remove and physically destroy any defective eyebolts. Replacement eyebolts are to be forged steel and meet the requirements of ASME B18.15 latest edition (available at [www.asme.org](http://www.asme.org)). Clean threads and install a replacement eyebolt with Loctite #262 (available at [www.loctite.com](http://www.loctite.com)) in the same orientation as original eyebolt. Allow Loctite to cure before using a replaced eyebolt for lifting. For eyebolt load capacity rating and if pulling on an eyebolt in a direction other than along the threaded axis, consult ASME B18.15.

The standard lifting lug and eyebolt materials can fail when subjected to shock loads at low ambient temperature conditions. Follow the guidelines in ASME B18.15. If deemed necessary by the customer or lifting professional, eyebolts may be replaced with forged eyebolts of materials more suitable for low temperatures, in accordance with ASME B18.15 and

ASTM F541 (available at [www.astm.org](http://www.astm.org)). Standard lifting lugs and bolting may also be replaced with materials more suitable for low temperatures. Contact Ariel for more information.

**CAUTION: When lifting a compressor designed for lifting lugs, use ONLY Ariel provided or approved lugs. Be sure the lugs are held in place with the proper grade of cap screws, and properly tightened. Lifting cable spreaders are required perpendicular to crankshaft axis. Be sure the crane capacity is adequate.**

## Setting the Compressor

1. Be sure the skid is level.
2. Move the compressor into place on the skid.
3. Level stationary compressors to Table 2-1 requirements. For compressors subject to transient motion on ships or offshore platforms, level compressors to table requirements when at rest. Be sure the pre-grout alignment is relatively close so that the equipment movement will be minimal and within the bolting, foot, push pads or grout box allowance.
4. Grout as required and allow grout to set.

With the compressor cylinders mounted but unsupported and with no piping or pulsation damping bottles attached, tighten the frame foot hold down bolting to skid at full fastener torque. Refer to Ariel ER-26, Appendix A in the Ariel Packager's Standards for proper frame foot torque values.

## Leveling Limits for Compressors

The limits in Table 2-1 assume that the running oil level is maintained between one half and two-thirds the height of the sight glass, except for dry sump compressors. Length leveling limits apply axially (parallel to crankshaft) and width limits apply horizontally (parallel to the piston rod) within the length and width of the frame.

**TABLE 2-1 Maximum Angle from a Horizontal Plane for Leveling Compressors**

Frame	Maximum Angle from a Horizontal Plane - In/Ft of Distance (mm/m) [ ° ]					
	1 or 2 Throw		4 Throw		6 Throw	
	Length	Width	Length	Width	Length	Width
JGM:N	0.420 (35) [2.°]	0.500 (42) [2.4°]	N/A			
JGP:Q	0.500 (42) [2.4°]	0.500 (42) [2.4°]	N/A			
JG	0.460 (38) [2.2°]	0.500 (42) [2.4°]	0.215 (18) [1.0°]	0.500 (42) [2.4°]	N/A	
JGA	0.500 (42) [2.4°]	0.500 (42) [2.4°]	0.310 (26) [1.5°]	0.500 (42) [2.4°]	0.190 (16) [0.9°]	0.500 (42) [2.4°]
JGW:R	0.095 (7.9) [0.45°]	0.500 (42) [2.4°]	0.025 (2.1) [0.1°]	0.500 (42) [2.4°]	N/A	
JGJ	0.420 (35) [2.°]	0.500 (42) [2.4°]	0.105 (8.7) [0.5°]	0.450 (37) [2.1°]	0.065 (5.4) [0.3°]	0.460 (38) [2.2°]
JGH	0.375 (31) [2°]	0.500 (42) [2.4°]	0.160 (13) [0.8°]	0.500 (42) [2.4°]	N/A	
JGE:T	0.440 (37) [2.1°]	0.500 (42) [2.4°]	0.155 (13) [0.7°]	0.500 (42) [2.4°]	0.090 (7.5) [0.4°]	0.310 (26) [1.5°]
JGK	0.105 (8.7) [0.5°]	0.500 (42) [2.4°]	0.035 (2.9) [0.2°]	0.500 (42) [2.4°]	0.020 (1.7) [0.1°]	0.310 (26) [1.5°]
JGC	0.270 (22) [1.3°]	0.460 (38) [2.2°]	0.100 (8.3) [0.5°]	0.460 (38) [2.2°]	0.060 (5.0) [0.3°]	0.180 (15) [0.9°]
JGD	0.500 (42) [2.4°]	0.460 (38) [2.2°]	0.205 (17) [1.0°]	0.460 (38) [2.2°]	0.125 (10) [0.6°]	0.180 (15) [0.9°]
JGZ	0.500 (42) [2.4°]	0.500 (42) [2.4°]	0.380 (25) [1.8°]	0.500 (42) [2.4°]	0.240 (20) [1.1°]	0.500 (42) [2.4°]
JGU	0.500 (42) [2.4°]	0.500 (42) [2.4°]	0.475 (40) [2.3°]	0.500 (42) [2.4°]	0.300 (25) [1.4°]	0.500 (42) [2.4°]
JGB	N/A		0.250 (21) [1.2°]	0.075 (6.2) [0.4°]	0.180 (15) [0.9°]	0.075 (6.2) [0.4°]
JGV	N/A		0.235 (20) [1.1°]	0.075 (6.2) [0.4°]	0.150 (12) [0.7°]	0.075 (6.2) [0.4°]
KBB:V	N/A		0.165 (14) [0.8°]	0.500 (42) [2.4°]	0.120 (10) [0.6°]	0.500 (42) [2.4°]

## Aligning Main Bearing Bores

To maximize main bearing life expectancy and help avoid crankshaft failures, it is essential that compressor frames be installed and remain in position so that main bearing bores can be maintained in proper alignment. Ariel has established this procedure in an effort to facilitate the proper installation of compressor frames and provide a means of periodic inspection.

1. The top cover mounting surface of an Ariel compressor frame is manufactured in a flat plane to a close tolerance. This surface is also held to a close tolerance with the main bearing bores and the bottom of the compressor feet. When the frame feet are supported so that the top-cover-mounting surface is flat "in plane", the main bearing bores are in alignment.
2. Top-cover-mounting surface flatness **or** soft foot check may be used for frame sizes up to and including JGU:Z/2-throw frames to be sure main bearing bores are in proper alignment, except for the JGI which uses only soft foot.
3. On JGU:Z:B:V:KBB:V/4-throw and /6-throw frames the top plane flatness **and** soft foot checks are **both** required to be sure the main bearing bores are in proper alignment.

- Measurements for flatness are to be taken on the top surface of both sides of the frame rails at each anchor bolt or for frames with pairs of anchor bolts between each pair of anchor bolts, with top covers and gaskets removed (see Figure 2-1). Readings between any two adjacent points are to be within .002 in. (0.05 mm). The total accumulated out of plane flatness for proper alignment is to be within the flatness tolerances listed in Table 2-1.

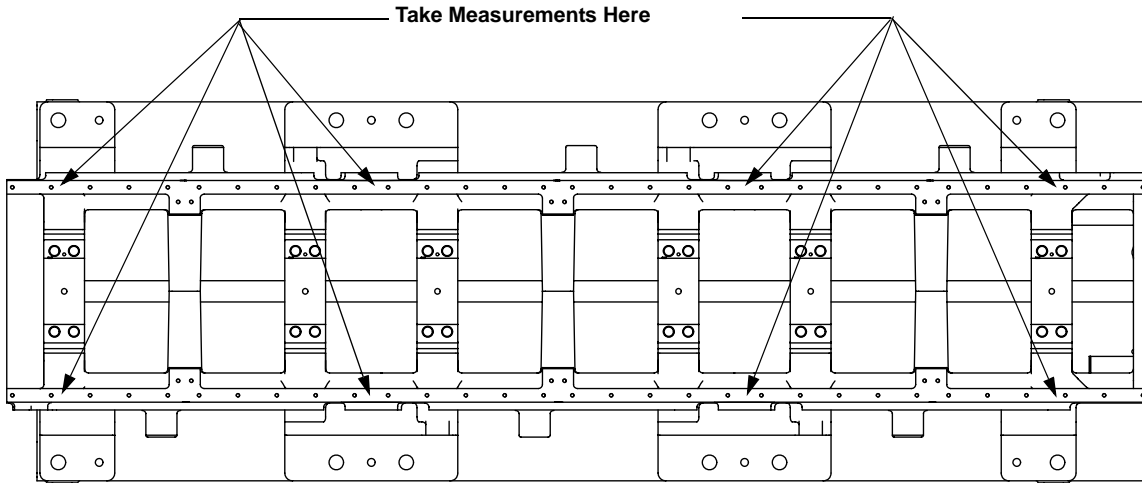


FIGURE 2-1 FLATNESS CHECK LOCATIONS - TYPICAL

TABLE 2-1 TOP-COVER-MOUNTING SURFACE - FLATNESS TOLERANCE

COMPRESSOR FRAME <sup>A</sup>	TOLERANCE FOR ALIGNMENT	
	INCHES	(mm)
JGM:N:P:Q/1/2, JG:A/2/4, JGR:J/2	0.004	(0.10)
JGA/6, JGR/4, JGJ/4/6, JGH:E:K:T/2/4, JGC:D/2/4, <u>JGU:Z/2/4</u> , <u>JGB:V/4</u> , <u>KBB:V/4</u>	0.006	(0.15)
JGE:K:T/6, JGC:D/6, <u>JGU:Z/6</u> , <u>JGB:V/6</u> , <u>KBB:V/6</u>	0.008	(0.20)

a. Underlined frames are required to use both top plane flatness and soft foot checks.

- In preparation for frame plane measurements be sure that the compressor frame hold down bolting is properly installed and tightened. Either remove or reposition the top cover(s) and gasket(s) to expose the frame's top-cover-mounting surface. With new unit installations it is recommended that the frame plane be initially checked prior to the guide feet being shimmed and after the initial rough coupling alignment. On KBB:V/6, or other model compressors shipped disassembled, the initial check can be carried out prior to the guide & cylinder assemblies being installed. Take the appropriate corrective shimming, or other height adjustment, action to have the top-cover-mounting surface fall within the specified plane tolerance. Subsequent reading should be taken and recorded after the guides and cylinders have been fully installed and then again after any vessels have been installed and shimmed. Corrective action is to be taken if guide, cylinder and/or vessel installation results in the frame top rail measure-

- ments not meeting the specified tolerances
6. Refer to Ariel ER-26, Appendix A in the Ariel Packagers Standard for proper frame foot and crosshead guide bolt size and torque values.
  7. Standard "wet-sump" compressors must be level within the "Maximum Angle from Horizontal Allowed without Dry Sump" to the Ariel Packager's Standards, ER-56.06.
  8. The top-cover-mounting surface should be measured for flatness and/or soft foot check be done as required:
    - a. When setting a new compressor.
    - b. After reinstalling a compressor frame.
    - c. When loose hold down fasteners are found.
    - d. Every 6 months or 4000 hours as recommended maintenance inspection.
  9. The Equipment used for flatness measurements should have a published accuracy of 0.0005 inches/foot (0.042 mm/m) over the required distance to measure the entire length of both frame rails. One example of such equipment is the "LEVALIGN Flatness application with ROTALIGN PRO" manufactured and supported by PRUFTECHNIK ([www.pruftechnik.com](http://www.pruftechnik.com)) which can be used to carry out the flatness inspection outlined above.
  10. To check soft foot, the compressor frame hold down bolting is to be properly installed and tightened. Loosen each hold down bolt individually while checking the frame foot to skid deflection with a calibrated dial indicator. Correct any hold down position that deflects more than 0.002 inches (0.05 mm) when released. Re-torque the hold down bolt and repeat at each frame to skid bolt.

## Setting Crosshead Guides

With crosshead guides and cylinders unsupported, prior to bottle installation:

1. Measure the clearances between each crosshead guide foot and the guide support. Except for JGZ:U and KBB:V frames when equipped with long two compartment (L2) crosshead guides, measure clearance at the outboard feet under the guide extension, which are used to support the guide and the feet under the guide are to be unsupported.
2. Completely fill the clearances with shim stock (reference Figure 2-2).
3. Tighten the crosshead guide foot (or long two compartment guide extension foot) to guide support hold-down bolting to full fastener torque. Refer to Ariel ER-26.

**FIGURE 2-2 CROSSHEAD GUIDE FOOT TO SKID-SUPPORT SHIM - TYPICAL**



4. Loosen the bolting while checking with a dial indicator to be sure that the clearance is completely filled and there is no deflection.
5. Using the information from the current **Ariel Performance Program**, determine the estimated crosshead guide foot deflection for JGH:E:K:T:C:D:Z:U:KBB:V frames. This calculated value is required to compensate for the deflection or droop of the cantilevered weight of the guide and cylinder. For the JG:A:M:N:P:Q:R:W:J frames, the guide and cylinder weights are not sufficient to deflect the guide.
6. Lift or jack cylinder, just slightly to allow insertion of additional shims based on the calculated value.
7. Re-tighten the crosshead guide hold down bolting to full fastener torque.
8. Repeat for each crosshead guide support.
9. Shims may need to be adjusted so that the crosshead to guide top and bottom clearances, and piston rod run-out measurements are within the tolerance requirements. Reference Section 5 for checking crosshead clearances and piston rod run-out, and Section 1 for tolerance limits.
10. For some applications, head-end cylinder supports may be desirable for larger classes of cylinders (bosses and tapped holes are provided on all K:T:C:D:Z:U:B:V class cylinders). See Ariel cylinder outline drawings for dimensional details. These supports must be adjusted and set when the components are at operating temperature.

## Setting - Miscellaneous

1. Reference Technical Manual Section 4 for protection of electronic equipment when arc welding.
2. Comply with the Ariel Start Up Check List, see Technical Manual Section 3.

## Alignment - to Driver

Proper alignment to the driver is necessary for satisfactory performance. A flexible coupling will not make up for poor alignment. Misalignment can result in:

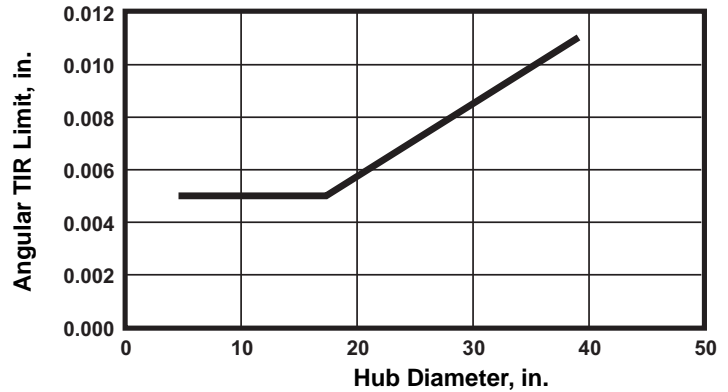
- High bending moment on the crankshaft.
- Large axial forces.
- Excessive bearing wear.
- And if severe, probable damage to various components.

### Procedural Requirements for Aligning a unit:

- Check the compressor frame, crosshead guide and driver hold-down bolting fastener torques.
- Check and correct the alignment of the compressor main bearing bores by the top-cover mounting surface flatness and/or soft foot, as applicable. The compressor and driver are to be laying flat. Check the driver's technical information for detailed instructions and determine that driver is laying flat.
- Correct the cold alignment readings with the predicted thermal growth values for both the compressor and the driver.
- Pre-lube the compressor frame using the compressor pre-lube pump prior to turning

the crankshaft.

- To ensure parallel and concentric drive train alignment, position connected equipment so total indicator (TIR) is as close to zero as possible on the coupling hub faces and rim diameters at normal operating temperature. Do not exceed 0.005 inches (0.13 mm) on the face and rim diameter. Except for coupling hubs with outside diameters above 17 in. (43 cm), the angular face TIR limit is  $0^{\circ} 1'$  or  $0.0167^{\circ}$ . See Figure 2-3. Correct for "Cold Alignment" on page 2-10.



**FIGURE 2-3 ANGULAR COUPLING-HUB ALIGNMENT TIR LIMITS**

Hub O.D. >17 in. x 0.00029 = angular TIR, in. max.

Hub O.D. >43 cm x 0.0029 = angular TIR, mm max.

- Center the coupling between the driver and the compressor so that it does not thrust or force the crankshaft against either thrust face.

**TABLE 2-2 Rexnord AMR/CMR Couplings - Face Angular TIR**

<b>Coupling Size</b>	<b>Flange OD, In. (cm)</b>	<b>Angular TIR, max., In. (mm)</b>
162	4.594 (11.7)	0.005 (0.13)
200	5.750 (14.6)	0.005 (0.13)
225	6.000 (15.2)	0.005 (0.13)
262	6.875 (17.5)	0.005 (0.13)
312	8.125 (20.6)	0.005 (0.13)
350	9.125 (23.2)	0.005 (0.13)
375	10.063 (25.6)	0.005 (0.13)
425	11.000 (27.9)	0.005 (0.13)
450	11.875 (30.2)	0.005 (0.13)
500	13.438 (34.1)	0.005 (0.13)
550	15.000 (38.1)	0.005 (0.13)
600	16.750 (42.6)	0.005 (0.13)
700	18.938 (48.1)	0.0055 (0.14)
750	20.625 (52.4)	0.0059 (0.15)
800	22.375 (56.8)	0.0064 (0.16)
850	23.750 (60.3)	0.0068 (0.17)
925	25.750 (65.4)	0.0074 (0.19)
1000	28.250 (71.8)	0.0081 (0.21)
1100	30.250 (76.8)	0.0087 (0.22)
1200	33.375 (84.8)	0.0096 (0.24)
1300	36.000 (91.4)	0.0104 (0.26)
1550	39.250 (99.7)	0.0113 (0.29)

TABLE 2-3 TB Woods HSH/FSH Couplings - Angular TIR

Coupling Size	Flange OD, In. (cm)	Angular TIR, max., In. (mm)
22	6.00 (15.2)	0.005 (0.13)
26	6.87 (17.5)	0.005 (0.13)
31	8.12 (20.6)	0.005 (0.13)
35	9.12 (23.2)	0.005 (0.13)
37	10.06 (25.6)	0.005 (0.13)
42	11.00 (27.9)	0.005 (0.13)
45	11.87 (30.1)	0.005 (0.13)
50	13.43 (34.1)	0.005 (0.13)
55	15.00 (38.1)	0.005 (0.13)
60	16.75 (42.5)	0.005 (0.13)
70	18.93 (48.1)	0.0055 (0.14)
75	20.62 (52.4)	0.0059 (0.15)
80	22.37 (56.8)	0.0064 (0.16)
85	23.75 (60.3)	0.0068 (0.17)
92	25.75 (65.4)	0.0074 (0.19)
105	29.25 (76.1)	0.0084 (0.21)
160	33.50 (85.1)	0.0096 (0.24)

- If dial indicator methods, are used, be sure that readings are repeatable.
- Correct for indicator arm sag.
- Check the crankshaft thrust, or end play, after any movements have been made. Both the compressor and driver shafts should “float” either direction and hold position. If the shafts resist float or “spring” back, the axial clearance must be corrected. See Section 1 for allowable compressor crankshaft thrust clearance values.
- Confirm that the alignment is within tolerance by checking the face and rim TIR at the coupling after all components are heat soaked.

When properly aligned, the forces on the connected equipment will be at a minimum. This will result in a smooth running unit and long bearing life.

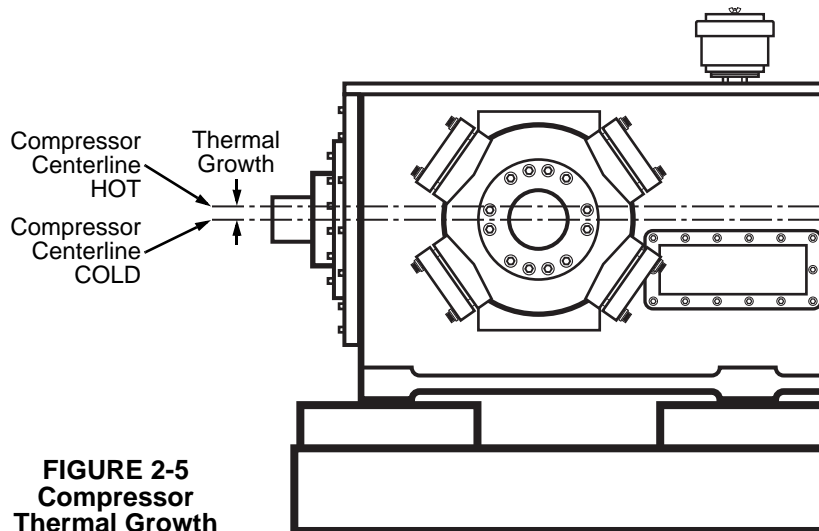
### Cold Alignment

Align the compressor to the driver taking into account the difference in thermal growth between the compressor and driver, so the face and rim TIR measurements at the coupling will be within the Figure 2-3 limits when equipment warms to the normal operating temperatures. Reference Figure 2-5 and Table 2-4 for the compressor centerline height change, based on  $6.5 \times 10^{-6}/^{\circ}\text{F}$  ( $11.7 \times 10^{-6}/^{\circ}\text{C}$ ) and a typical differential temperature increase of  $100^{\circ}\text{F}$  ( $55.6^{\circ}\text{C}$ ). For other significantly different predicted differential temperature increases, the thermal growth value may be calculated for the compressor. Refer to the driver manufacturer's thermal growth prediction for the driver differential temperature increase to normal operating temperature.

When larger compressors are shipped with the crosshead guides removed, it may be desirable to align the frame to the driver prior to installing the guides and crossheads. Frames shipped without guides after July 13, 2007 are provided with temporary plates, through bolts and protective sleeves at each connecting rod bushing. This allows for the frame to be properly pre-lubed prior to turning the crankshaft for alignment. The temporary hardware at the connecting rods is then removed (and discarded) prior to installing the crosshead guides and crossheads. When removing this temporary hardware, oil may flow from the rod bushing cavity behind the plates. A catch basin to prevent oil spillage is recommended.

### Hot Alignment

After 24 to 48 hours of full load operation, or when entire skid and block mount is heat soaked, TIR measurements at the rim of the coupling are not to exceed 0.005 inches (0.13 mm) and on the face are to be within the Table 2-2 or Table 2-3 limits. If not within the these limits, re-align the compressor.



**FIGURE 2-5**  
Compressor  
Thermal Growth

**TABLE 2-4 Typical Thermal Growth Predictions**

Frame Model	THERMAL GROWTH	
	Inches	(mm)
JGM:N:P:Q	0.006	(0.15)
JG:A:I	0.007	(0.18)
JGR:W:J	0.008	(0.20)
JGH:E:K:T	0.011	(0.28)
JGC:D	0.014	(0.36)
JGZ:U	0.016	(0.41)
KBB:V	0.018	(0.46)
JGB:V	0.020	(0.51)

## Alignment Methods

1. Laser - the preferred method for JGC:D:Z:U:B:V and KBB:V frames.
2. Face/Rim Dial Indicator Measurements at Coupling.
3. Reverse Indicator.
4. Optical.
5. Mechanical direct to computer.

## Electrical Grounding

**CAUTION: The compressor skid must be wired to a suitable earth ground to reduce the potential for electric shock injury, while protecting the equipment. Refer to the local electrical codes to determine a suitable ground rod.**

## Pneumatically Actuated Unloaders & Clearance Devices

When compressor cylinders are equipped with pneumatically actuated unloaders or clearance devices, care must be taken to be sure that the actuating air or gas system is appropriately vented, and that the system incorporates provisions that will not allow the process gas to back flow into the actuating air or gas system.

The control media supply system and vent system for the unloader must provide for the safe and effective operation of the unloader throughout the full range of compressor operating conditions. ACI, an Ariel supplier, has published a document outlining system design and requirements. Please reference this document for system design and evaluation. The document may be found at support/vendor literature/reciprocating compressors/ACI on the Ariel web site: [www.arielcorp.com](http://www.arielcorp.com).

## Vents and Drains

It is critical, for the safe operation of the compressor, to be sure that all vents and drains are open, functional and, if necessary, tubed off of the skid or out of the building to a safe atmosphere. The venting of gases and vapors, and the disposal of drained fluids should be environmentally safe. Depending upon your climate and insect population it can be necessary to install screens over the vents and drains to be sure that they do not become blocked. This can be essential if the compressor is shutdown for a long period of time.

Some other points are:

1. A blow-down vent must be provided to safely relieve pressure from the system for maintenance purposes. Any vent or blowdown line connected to a common vent or flare header must have a back-flow prevention check valve.
2. Adequate vents and drains will be provided for the distance piece, and primary packing vent. Primary vents and drains shall be independently vented from the secondary vents and drains. All vents and drains shall be installed in such a manner as to prevent the collection of liquids that could cause the build-up of either gas or liquid. When a heavier than air gas is involved, vent and drain

design must be accommodating.

3. When the crankcase breather is mounted remotely, the piping must be configured so there is no back pressure and so condensation in the piping does not drain into the crankcase.

## **BICERA Type Crankcase Over-Pressure Relief Valves**

Compressors supplied with optional BICERA type valves, are shipped with standard solid crosshead guide covers installed to provide a 100% seal and prevent any exchange of atmosphere during shipping or storage. The BICERA valves are boxed and shipped separately. The BICERA valves are to be installed on the compressor crosshead guides just prior to startup.

- A valve may be placed on any throw by replacing a standard crosshead guide cover, except when one valve per throw pair is supplied, then each pair of throws is to have a valve.
- Replacement paper gaskets are provided, if needed. Before installing the valves, apply an anti-seize lubricant to both sides of new gasket surfaces, when replacement gaskets are needed. This will ease future removal.
- Tighten cap screws hand wrench tight.
- The crosshead guide covers which are replaced with BICERA relief valve assemblies, may be put into the customer's parts inventory or scrapped as desired.

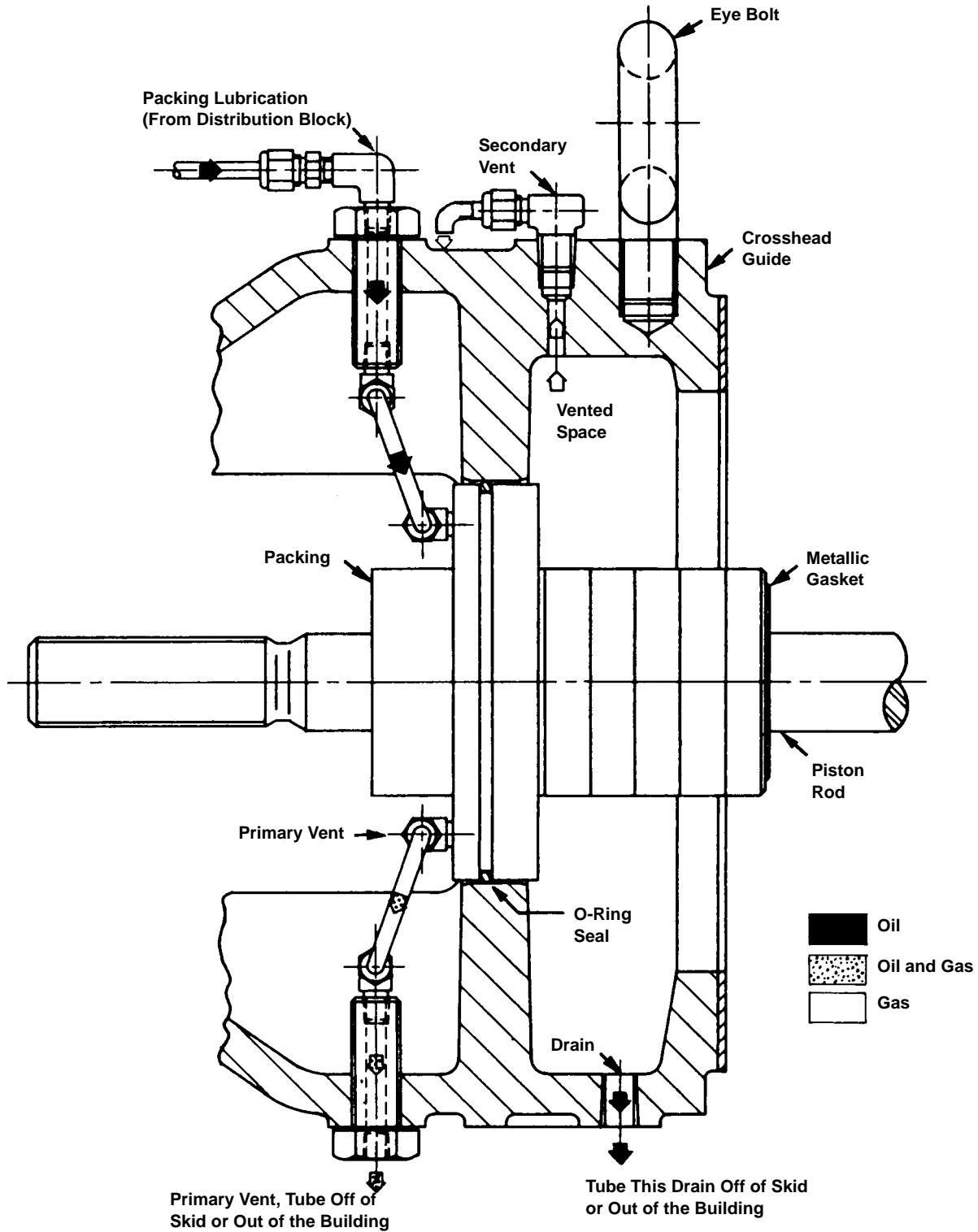
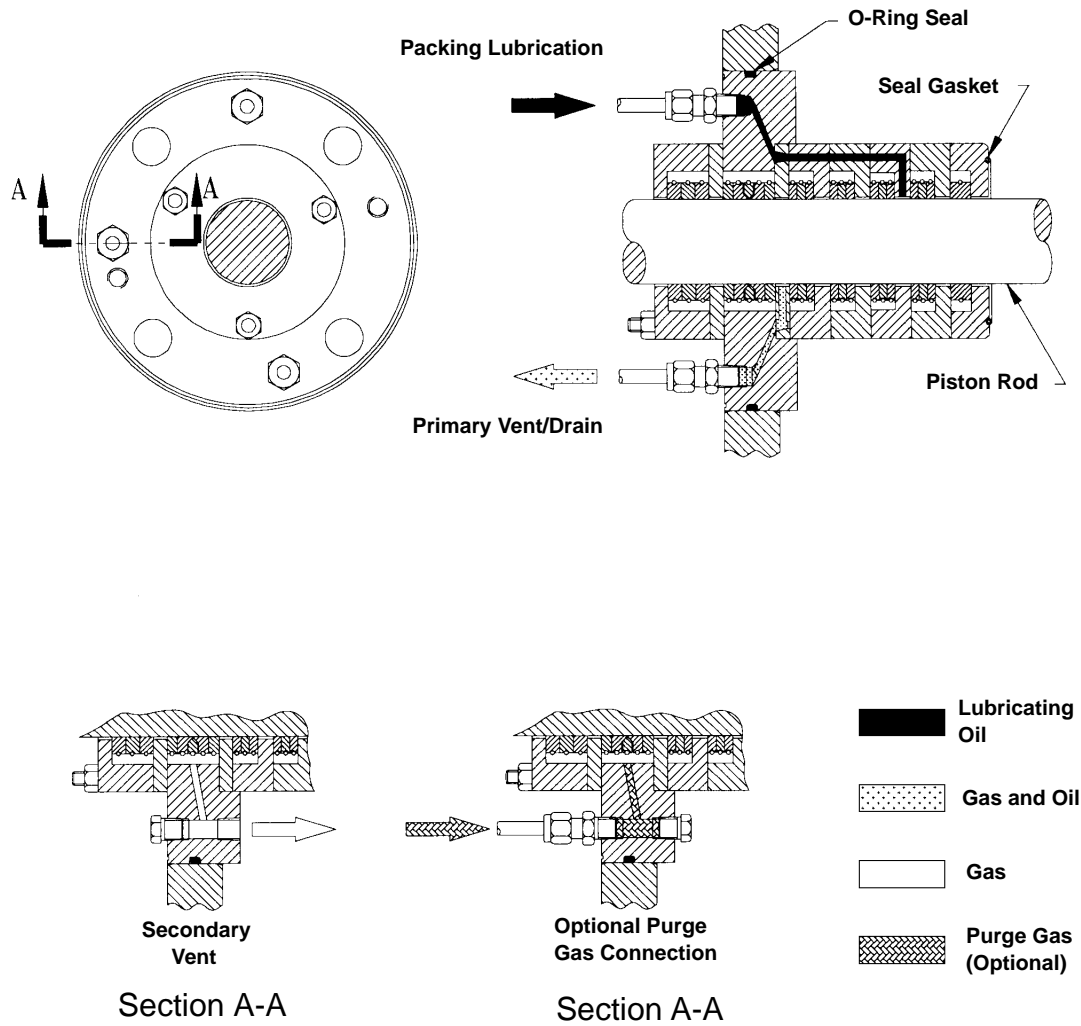


FIGURE 2-4 PACKING, TUBING AND DISTANCE PIECE VENTING





**FIGURE 2-5 PACKING LUBRICATION AND VENTING**

## SECTION 3 - START UP

### General

To be sure that start up goes smoothly, it is important that the items in the Start Up Check List, provided in this section, be positively satisfied. It is also important that the operator understand how to operate the compressor in a safe and efficient manner, prior to start up.

#### CAUTION

BEFORE STARTING A NEW COMPRESSOR, OR AFTER RELOCATING OR REAPPLYING A COMPRESSOR, OR AFTER MAJOR OVERHAUL, BE SURE TO COMPLETE AND CHECK OFF ALL THE ITEMS ON THE START UP CHECK LIST IN THIS SECTION. THIS LIST IS DESIGNED TO MAXIMIZE SAFETY IN STARTING AND OPERATING THE COMPRESSOR.

#### CAUTION

FOR SAFE OPERATION, DO NOT ATTEMPT TO START-UP THE UNIT WITHOUT BEING COMPLETELY KNOWLEDGEABLE OF THE INFORMATION CONTAINED IN THIS SECTION. IT IS ALSO ESSENTIAL TO REFER TO THE PACKAGER'S OPERATING MANUAL.

### Start Up Check List

For the latest available Start Up Check List, refer to ER-10.4.01 at [www.arielcorp.com](http://www.arielcorp.com).

# Warranty Notification - Installation List Data and Start Up Check Lists for JG:A:M:N:P:Q:R:J:H:E:K:T:C:D Reciprocating Compressors

The following forms are designed to ensure a successful start-up of smaller Ariel reciprocating compressor models. Ariel warranty coverage requires these completed forms sent to:

Administrative Assistant - Sales, Ariel Corporation  
 35 Blackjack Road • Mount Vernon, Ohio 43050 USA  
 Phone: 740-397-0311 • FAX: 740-397-3856

## Warranty Notification - Installation List Data

Date: \_\_\_\_\_ Name: \_\_\_\_\_

Unassigned    Resale    Direct Sale    Lease-Purchase    Rental/Lease Unit

### Compressor Frame

Frame Model: \_\_\_\_\_ Frame Serial #: \_\_\_\_\_

Frame Lubricant Make and Grade: \_\_\_\_\_

Package Startup Date: \_\_\_\_\_

### Distributor/Fabricator

Company: \_\_\_\_\_ Name: \_\_\_\_\_

Address: \_\_\_\_\_

City: \_\_\_\_\_ State: \_\_\_\_\_ Zip: \_\_\_\_\_ Country: \_\_\_\_\_

Fabricator Unit Number: \_\_\_\_\_

### Application

Air/Nitrogen    CNG/GNC    FPSO    Gathering    Fuel Gas Booster  
 Refrigeration    Pipeline    PRC    Injection    Storage/Withdrawal    Miscellaneous

Elevation: \_\_\_\_\_

H<sub>2</sub>S%: \_\_\_\_\_ CO<sub>2</sub>%: \_\_\_\_\_ Specific Gravity: \_\_\_\_\_ Non-Lube:  Yes  No

**Unit Location**

Customer Name: \_\_\_\_\_

Project/Lease Name: \_\_\_\_\_

Closest Town: \_\_\_\_\_ State: \_\_\_\_\_ Country: \_\_\_\_\_ Offshore:  Yes  No

Directions to Location or GPS: \_\_\_\_\_

\_\_\_\_\_  
 \_\_\_\_\_  
 \_\_\_\_\_

Customer Contact Person: \_\_\_\_\_ Contact Phone: \_\_\_\_\_

Contact Email: \_\_\_\_\_ OK to contact:  Yes  No

**Driver**

Driver Manufacturer: \_\_\_\_\_ Driver Model: \_\_\_\_\_

Driver Type: \_\_\_\_\_ Applied RPM: \_\_\_\_\_ Name Plate HP (kW): \_\_\_\_\_

Coupling Manufacturer: \_\_\_\_\_ Coupling Model: \_\_\_\_\_

**Compressor Cylinders and Operating Conditions**

Cylinder Class	Stage Number	Throw Number	Serial Number	Bore Dia. In. (mm)	Inlet Temp. °F (°C)	Inlet Pres. psig (Bar <sub>g</sub> )	Disc. Temp. °F (°C)	Disc. Pres. psig (Bar <sub>g</sub> )
_____	_____	_____	_____	_____	_____	_____	_____	_____
_____	_____	_____	_____	_____	_____	_____	_____	_____
_____	_____	_____	_____	_____	_____	_____	_____	_____
_____	_____	_____	_____	_____	_____	_____	_____	_____
_____	_____	_____	_____	_____	_____	_____	_____	_____
_____	_____	_____	_____	_____	_____	_____	_____	_____

Cylinder Lubricant Make and Grade: \_\_\_\_\_

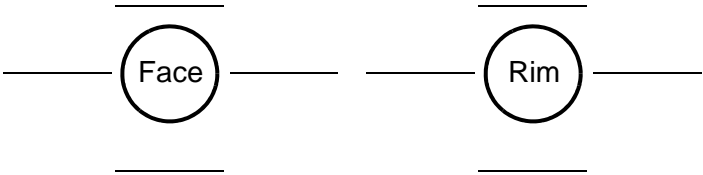
**Documentation and Accessories**

Check all items included in the shipment:

- Technical Manual  Yes  No
- Start-Up Spare Parts  Yes  No
- Toolbox w/Ariel Tools  Yes  No
- Unit Parts List  Yes  No
- Recommended Spares List  Yes  No
- Unit Start and Stop Procedures  Yes  No
- Toolbox with Hydraulic Tools  Yes  No (Optional)
- Toolbox with SAE Hand Tools  Yes  No (Optional)

START-UP CHECK LIST - ITEMS TO CHECK IN THE FIELD AT COMMISSIONING		
Description	Date Checked	Date Verified
1. Check and verify the top cover data plate of the compressor frame for compressor design limitations such as rod load, maximum and minimum speed, and maximum lube oil temperature.	Commissioning Agent: _____	Distributor: _____
2. Check and verify the availability of correct start-up spares, hand tools, special tools, compressor parts list and drawings, and technical manuals at installation.	Commissioning Agent: _____	Distributor: _____
3. Check and verify the Ariel lube sheet and Lubrication Specification matches the recommended oil grade and viscosity for the service.	Commissioning Agent: _____	Distributor: _____
4. Check and verify all lube oil piping cleanliness per Ariel lubrication specifications (see Technical Manual, Section 4).	Commissioning Agent: _____	Distributor: _____
5. Verify lube oil storage and supply line cleanliness per ER-56.06. Verify crankcase oil supply isolation valve is open.	Commissioning Agent: _____	Distributor: _____
6. Verify prelube piping cleanliness per ER-56.06 and correct circuit operation.	Commissioning Agent: _____	Distributor: _____
7. Verify there is an oil cooler and high temperature shut-down for the oil into the compressor frame.	Commissioning Agent: _____	Distributor: _____
8. Verify whether the temperature control valve installation is blending or diverting (blending preferred). _____	Commissioning Agent: _____	Distributor: _____
9. Check compressor crankcase oil level controller for proper installation, operation, levelness, and venting.	Commissioning Agent: _____	Distributor: _____
10. If applicable, check cooling water circuit cleanliness for the oil cooler and cooled packing per Technical Manual. Verify correct routing and test pump rotation. Set pressure appropriately per Technical Manual and leak test.	Commissioning Agent: _____	Distributor: _____
11. Verify correct filter element installation. Prime the oil filter element and all lube oil piping with oil.	Commissioning Agent: _____	Distributor: _____
12. Verify proper compressor crankcase oil level before starting (about 7/8 full in site glass).	Commissioning Agent: _____	Distributor: _____
13. Verify correct installation of a low oil pressure shutdown tubed to the downstream side of the oil filter.	Commissioning Agent: _____	Distributor: _____
14. Operate pre-lube system.	Commissioning Agent: _____	Distributor: _____
15. <b>OPTIONAL STEP:</b> Record "out of plane" readings (pre-grout) - see ER-82.		
<p><b>Drive End</b>      _____      _____      _____      _____      _____      _____      _____      _____      _____</p> <p>_____      _____      _____      _____      _____      _____      _____      _____      _____      _____</p>	<p><b>Auxiliary End</b></p>	<p>Commissioning Agent: _____</p> <p>Distributor: _____</p>
16. Record soft foot readings. More than 0.002 inches (0.05 mm) pull-down on any frame foot requires correction. See Technical Manual.		
<p><b>Drive End</b>      _____      _____      _____      _____      _____      _____      _____      _____      _____</p> <p>_____      _____      _____      _____      _____      _____      _____      _____      _____      _____</p>	<p><b>Auxiliary End</b></p>	<p>Commissioning Agent: _____</p> <p>Distributor: _____</p>

START-UP CHECK LIST - ITEMS TO CHECK IN THE FIELD AT COMMISSIONING																														
Description	Date Checked	Date Verified																												
17. Check crosshead guide shimming for correct pre-load and hold down bolt torque.	Commissioning Agent: _____	Distributor: _____																												
18. Record piston end clearances with feeler gages (see Technical Manual, Section 1, Clearances). <table style="width:100%; border-collapse: collapse;"> <tr> <td style="width: 10%;"><b>Throw</b></td> <td style="width: 10%; text-align: center;"><b>1</b></td> <td style="width: 10%; text-align: center;"><b>2</b></td> <td style="width: 10%; text-align: center;"><b>3</b></td> <td style="width: 10%; text-align: center;"><b>4</b></td> <td style="width: 10%; text-align: center;"><b>5</b></td> <td style="width: 10%; text-align: center;"><b>6</b></td> </tr> <tr> <td><b>Head End</b></td> <td>_____</td> <td>_____</td> <td>_____</td> <td>_____</td> <td>_____</td> <td>_____</td> </tr> <tr> <td><b>Crank End</b></td> <td>_____</td> <td>_____</td> <td>_____</td> <td>_____</td> <td>_____</td> <td>_____</td> </tr> </table> <p><b>NOTE: Pre-lube compressor before turning crank-shaft.</b></p>	<b>Throw</b>	<b>1</b>	<b>2</b>	<b>3</b>	<b>4</b>	<b>5</b>	<b>6</b>	<b>Head End</b>	_____	_____	_____	_____	_____	_____	<b>Crank End</b>	_____	_____	_____	_____	_____	_____	Commissioning Agent: _____	Distributor: _____							
<b>Throw</b>	<b>1</b>	<b>2</b>	<b>3</b>	<b>4</b>	<b>5</b>	<b>6</b>																								
<b>Head End</b>	_____	_____	_____	_____	_____	_____																								
<b>Crank End</b>	_____	_____	_____	_____	_____	_____																								
19. Measure and record rod run out (see Technical Manual, Section 5 for maximum acceptable readings). <table style="width:100%; border-collapse: collapse;"> <tr> <td style="width: 10%;"><b>Throw</b></td> <td style="width: 10%; text-align: center;"><b>1</b></td> <td style="width: 10%; text-align: center;"><b>2</b></td> <td style="width: 10%; text-align: center;"><b>3</b></td> <td style="width: 10%; text-align: center;"><b>4</b></td> <td style="width: 10%; text-align: center;"><b>5</b></td> <td style="width: 10%; text-align: center;"><b>6</b></td> </tr> </table> <p><b>Vertical:</b></p> <p><b>Piston @ CE</b> _____</p> <p><b>Mid-Stroke</b> _____</p> <p><b>Piston @ HE</b> _____</p> <p><b>Horizontal:</b></p> <p><b>Piston @ CE</b> _____</p> <p><b>Mid-Stroke</b> _____</p> <p><b>Piston @ HE</b> _____</p> <p><b>NOTE: Pre-lube compressor before turning crank-shaft.</b></p>	<b>Throw</b>	<b>1</b>	<b>2</b>	<b>3</b>	<b>4</b>	<b>5</b>	<b>6</b>	Commissioning Agent: _____	Distributor: _____																					
<b>Throw</b>	<b>1</b>	<b>2</b>	<b>3</b>	<b>4</b>	<b>5</b>	<b>6</b>																								
20. Measure crosshead clearances with cylinders mounted. To check top, insert 0.5 inch (12.7 mm) wide feelers from one side edge across to the opposite side, at both ends. See Technical Manual, Section 1 for limits. To check bottom, insert a 0.0015 inches (0.038 mm) feeler at the four corners; feeler should insert no more than 0.50 (13 mm). Record feeler values below: <table style="width:100%; border-collapse: collapse;"> <tr> <td style="width: 10%;"><b>Throw</b></td> <td style="width: 15%;"><b>Top Min.</b></td> <td style="width: 15%;"><b>Top Max.</b></td> <td style="width: 15%;"><b>Bottom Max. (Corners)</b></td> </tr> <tr> <td><b>1</b></td> <td>_____</td> <td>_____</td> <td>_____</td> </tr> <tr> <td><b>2</b></td> <td>_____</td> <td>_____</td> <td>_____</td> </tr> <tr> <td><b>3</b></td> <td>_____</td> <td>_____</td> <td>_____</td> </tr> <tr> <td><b>4</b></td> <td>_____</td> <td>_____</td> <td>_____</td> </tr> <tr> <td><b>5</b></td> <td>_____</td> <td>_____</td> <td>_____</td> </tr> <tr> <td><b>6</b></td> <td>_____</td> <td>_____</td> <td>_____</td> </tr> </table>	<b>Throw</b>	<b>Top Min.</b>	<b>Top Max.</b>	<b>Bottom Max. (Corners)</b>	<b>1</b>	_____	_____	_____	<b>2</b>	_____	_____	_____	<b>3</b>	_____	_____	_____	<b>4</b>	_____	_____	_____	<b>5</b>	_____	_____	_____	<b>6</b>	_____	_____	_____	Commissioning Agent: _____	Distributor: _____
<b>Throw</b>	<b>Top Min.</b>	<b>Top Max.</b>	<b>Bottom Max. (Corners)</b>																											
<b>1</b>	_____	_____	_____																											
<b>2</b>	_____	_____	_____																											
<b>3</b>	_____	_____	_____																											
<b>4</b>	_____	_____	_____																											
<b>5</b>	_____	_____	_____																											
<b>6</b>	_____	_____	_____																											
21. For electric motor drivers, check and verify the motor shaft is set at its magnetic center before positioning axial clearance. With the coupling disconnected, check and verify driver rotation matches the compressor rotation arrow.	Commissioning Agent: _____	Distributor: _____																												
22. Check coupling bolt torque to coupling manufacturer recommendations.	Commissioning Agent: _____	Distributor: _____																												

START-UP CHECK LIST - ITEMS TO CHECK IN THE FIELD AT COMMISSIONING		
Description	Date Checked	Date Verified
<p>23. Check and verify compressor to driver alignment (installed on site, cold). Record dial indicator readings in inches (mm) at the 3, 6, 9 and 12 o'clock positions or attach alignment tool print-out.</p> <div style="text-align: center;">  </div> <p>If using a laser alignment tool, make a print out and attach it to this document.</p>	<p>Commissioning Agent: _____</p>	<p>Distributor: _____</p>
<p>24. Check and verify compressor crankshaft thrust clearance. The shaft should remain stationary after thrusting each direction (see Technical Manual, Clearances).</p> <p>_____</p>	<p>Commissioning Agent: _____</p>	<p>Distributor: _____</p>

START-UP CHECK LIST - PROCESS PIPING VENTS AND DRAINS		
Description	Date Checked	Date Verified
<p>1. Verify the bottle and process pipe installation contains no bolt bound flanges or elevation differences that may stress the compressor cylinders</p>	<p>Commissioning Agent: _____</p>	<p>Distributor: _____</p>
<p>2. Verify cold adjustment of any bottle or cylinder supports.</p>	<p>Commissioning Agent: _____</p>	<p>Distributor: _____</p>
<p>3. Verify correct inlet screen orientation in process piping.</p>	<p>Commissioning Agent: _____</p>	<p>Distributor: _____</p>
<p>4. Check and verify vents and drains of the primary and secondary packing-case and the crosshead distance piece are open and tubed to a safe atmosphere.</p>	<p>Commissioning Agent: _____</p>	<p>Distributor: _____</p>
<p>5. Check and verify safety relief valve installation to protect cylinders, piping, and cooler for each compression stage.</p>	<p>Commissioning Agent: _____</p>	<p>Distributor: _____</p>
<p>6. Record method of suction pressure control and valve size.</p> <p>_____</p>	<p>Commissioning Agent: _____</p>	<p>Distributor: _____</p>
<p>7. Check and verify crankcase breather element is open to atmosphere and clean.</p>	<p>Commissioning Agent: _____</p>	<p>Distributor: _____</p>
<p>8. Check and verify torque to spec on all gas containment and other fasteners where loosening may result in a safety hazard or equipment failure including: gas nozzle flanges, valve caps, cylinder heads, compressor rod packing, and crosshead guide support. See ER-63.</p>	<p>Commissioning Agent: _____</p>	<p>Distributor: _____</p>

START-UP CHECK LIST - INSTRUMENTATION		
Description	Date Checked	Date Verified
1. Check and verify the set point for the high compressor oil temperature shutdown at 190°F (88°C) maximum.	Commissioning Agent: _____	Distributor: _____
2. Check and verify proper vibration shutdown installation and operation. Record alarm and shut down settings.  _____ _____ _____	Commissioning Agent: _____	Distributor: _____
3. Verify operation of suction pressure, inter-stage pressure, and discharge pressure shutdowns. Record alarm and shutdown settings.  _____ _____ _____	Commissioning Agent: _____	Distributor: _____
4. Verify gas discharge temperature shutdowns operation. Record alarm and shutdown settings.  _____ _____ _____	Commissioning Agent: _____	Distributor: _____
5. Check, verify, and record the over speed setting. _____	Commissioning Agent: _____	Distributor: _____

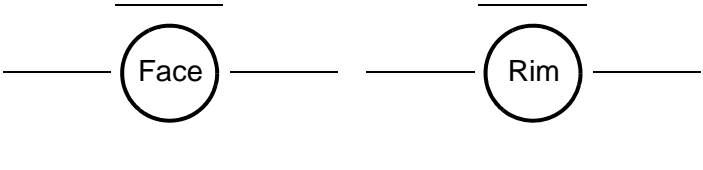
START-UP CHECK LIST - FORCE FEED LUBRICATION SYSTEM		
Description	Date Checked	Date Verified
1. Check and verify force feed lubricator box for proper oil level.	Commissioning Agent: _____	Distributor: _____
2. Prime the force feed lubrication system through the purge port at the force feed pump discharge manifold. Check and verify each tube connection for tightness	Commissioning Agent: _____	Distributor: _____
3. Check and verify operation of force feed lubrication system no flow shutdowns.	Commissioning Agent: _____	Distributor: _____
4. Record color of force feed blow out discs (see Customer Technical Bulletin CTB-137 for disc ratings). _____	Commissioning Agent: _____	Distributor: _____
5. Check, verify, and record recommended lube feed rates from lubricator data plate or "Parts Book" Cylinder Lubrication sheet. _____	Commissioning Agent: _____	Distributor: _____



FINAL PRE-START CHECK LIST		
Description	Date Checked	Date Verified
1. Operate pre-lube system. Record pre-lube pressure. _____		
2. For engine driven units, disable the ignition and roll the engine with the starter to check and verify the compressor rolls freely. Check and verify oil pressure increases noticeably while rolling on the starter.	Commissioning Agent: _____	Distributor: _____
3. For electric motors, bar the compressor over manually to check and verify it rolls freely.	Commissioning Agent: _____	Distributor: _____
4. For machines compressing a combustible gas, purge the entire system including the piping, by-pass, recycle line, and compressor cylinders of all air.	Commissioning Agent: _____	Distributor: _____
5. Review start-up instructions for all other package components.	Commissioning Agent: _____	Distributor: _____
6. Complete the required review of the Start-Up and Operating Instructions for the unit with the unit operator.	Commissioning Agent: _____	Distributor: _____

INITIAL POST START-UP CHECK LIST		
Description	Date Checked	Date Verified
1. Check and verify immediate oil pressure increase. Enable oil pressure shutdown and bearing temperature shutdowns. Record initial pressure at operating speed. _____	Commissioning Agent: _____	Distributor: _____
2. Check and verify oil filter pressure gauges. Record initial differential. _____	Commissioning Agent: _____	Distributor: _____
3. Check and verify the low oil pressure shutdown is active and set at 45 psig (3.1 bar <sub>g</sub> ).	Commissioning Agent: _____	Distributor: _____
4. Check and verify lube oil pressure set at 50 to 60 psig (3.5 to 4.2 bar <sub>g</sub> ) at operating speed and temperature (see Technical Manual, Section 4). Record final setting. _____	Commissioning Agent: _____	Distributor: _____
5. Record oil filter maximum differential reference value listed on the compressor top cover filter data plate. _____	Commissioning Agent: _____	Distributor: _____
6. Listen and feel for any strange noises or vibration in the compressor or piping. Record any occurrences. _____ _____ _____ _____	Commissioning Agent: _____	Distributor: _____
7. Check and verify high discharge gas temperature shutdowns are set about 10% above normal operating temperature (350 °F (177 °C) maximum) and functioning.	Commissioning Agent: _____	Distributor: _____

INITIAL POST START-UP CHECK LIST		
Description	Date Checked	Date Verified
8. Check and verify distribution block cycle time indicator and set lubricator pump for proper break-in rate.	Commissioning Agent: _____	Distributor: _____
9. Check and verify the unit and piping is free from any gas or fluid leaks. Record any occurrences.  _____  _____  _____	Commissioning Agent: _____	Distributor: _____
10. Check and verify scrubber high level shutdowns operation and check scrubber dumps operation and frequency.	Commissioning Agent: _____	Distributor: _____
11. Check, verify, and record tank levels that indicate the amount of liquids removed from the gas.  _____	Commissioning Agent: _____	Distributor: _____
12. Check and verify piston rod packings seal properly in the primary packing vents.	Commissioning Agent: _____	Distributor: _____
13. Check and verify operation of all safety functions to ensure unit shutdown upon indication.	Commissioning Agent: _____	Distributor: _____
14. If applicable, check and verify main bearing temperatures and record. Watch for even bearing temperature increase.	Commissioning Agent: _____	Distributor: _____
15. During various operational conditions, use the Ariel performance program to check and verify operational characteristics of various load steps.	Commissioning Agent: _____	Distributor: _____

24-HOUR POST START-UP CHECK LIST		
Description	Date Checked	Date Verified
<p>1. Record "hot" alignment readings after reaching normal operating temperatures and components become heat soaked. Shutdown and vent gas system. Within 30 minutes and while components are still hot, record dial indicator readings in inches (mm) at the 3, 6, 9 and 12 o'clock positions on lines provided below:</p> <div style="text-align: center;">  </div> <p>If using a laser alignment tool, make a print out and attach it to this document.</p>	<p>Commissioning Agent: _____</p>	<p>Distributor: _____</p>
<p>2. If using a discharge bottle or head end cylinder supports, adjust when components are heat soaked to ensure no excessive forces exist to cause detrimental cylinder deflection.</p>	<p>Commissioning Agent: _____</p>	<p>Distributor: _____</p>
<p>3. Check and verify torque on gas nozzle flange, valve cap, cylinder head, compressor rod packing flange, and guide to frame bolting.</p>	<p>Commissioning Agent: _____</p>	<p>Distributor: _____</p>
<p>4. Complete Ariel's "Compressor Warranty Notification - Installation List Data" (pages 1 and 2).</p>	<p>Commissioning Agent: _____</p>	<p>Distributor: _____</p>
750-HOUR POST START-UP CHECK LIST		
Description	Date Checked	Date Verified
<p>1. Check and verify torque on gas nozzle flange, valve cap, cylinder head, and compressor rod packing flange bolting.</p>	<p>Commissioning Agent: _____</p>	<p>Distributor: _____</p>
<p>2. Send completed form and check lists (pages 1-12) to Ariel as noted on page 1.</p>	<p>Commissioning Agent: _____</p>	<p>Distributor: _____</p>

## Maximum Allowable Working Pressure

All Ariel Compressor Cylinders have a "Maximum Allowable Working Pressure (MAWP)". The MAWP, the hydrostatic test pressure, and the test date are stamped on the end of every Ariel cylinder.



# CAUTION

**OPERATING CONDITIONS MUST NOT EXCEED CYLINDER DESIGN LIMITATIONS.**

Maximum allowable working pressure is the maximum continuous gauge pressure for which the compressor manufacturer has designed the equipment (or relevant part thereof) when handling the specified fluid at the specified temperature.

Maximum allowable working pressure of compressor cylinders shall exceed the rated discharge pressure by at least 10 %, or 25 psi (1.7 bar), whichever is greater. The maximum allowable working pressure shall be at least equal to the specified relief valve set pressure including accumulation. The rated discharge pressure (RDP) is the highest pressure required to meet the conditions specified by the purchaser for the intended service.

## Relief Valve Settings

It is the responsibility of the packager to provide relief valves for every stage of compression in compliance with ISO 13631. Relief valve location and settings, including accumulation, shall take into consideration all possible types of equipment failure, mal-operation and the protection of piping systems. Relief valves shall be set to operate at not more than the maximum allowable working pressure, but not less than the values listed in ISO 13631:

### CAUTION

**WHEN A BYPASS IS FURNISHED, A RELIEF VALVE MUST BE INSTALLED IMMEDIATELY DOWNSTREAM OF THE BYPASS VALVE OR ON THE INLET SCRUBBER OF THE DOWNSTREAM CYLINDER. THIS RELIEF VALVE MUST NOT BE SET HIGHER THAN THE MAXIMUM ALLOWABLE WORKING PRESSURE OF THE CYLINDER WHICH HAS THE LOWEST MAWP OF THOSE IN THE BYPASS CIRCUIT. THIS IS TO PROTECT AGAINST DISCHARGE CHECK-VALVE FAILURE WHEN OPERATING ON BYPASS.**

## Filling Sump & Priming a Main Oil Lube Oil System - Before Starting

### Filling The Sump

1. For compressors with automated lubricating oil fill systems, activate to fill the oil sump.
2. For compressors without automated fill which use the crankcase as the oil sump, remove breather and fill compressor sump with lubricating oil through top cover. When the sump is filled to the proper level, replace and snug up the breather cap by hand, to facilitate later removal.
3. Check sight glass on auxiliary end. Oil level at start-up should be near the top of

the glass. DO NOT OVERFILL SUMP. The crankshaft will dip into the oil, churn it, and make it difficult to pump and to control the proper level. (After the machine is running, it may be necessary to add oil to bring up oil level to one-half the height of the sight glass; but it must never exceed two-thirds height while running.)

4. For compressors with separate oil sump, fill sump with lubricating oil as required.

## Priming - Main Lube Oil System

**BE SURE THE OIL SYSTEM FROM THE LUBE OIL PUMP THROUGH THE COOLER AND OIL FILTER IS FILLED WITH OIL.**

Remove cover doors and operate the prelube pump to verify that oil is dripping from the bearing and crosshead positions.

## Compressor Prelube

See Section 4 "Compressor Prelube" for the prelube requirements for starting the compressor.

## Force Feed Lubricator Adjustment

Be sure that the force feed lubricator pumps are set at the break-in rate shown on the force feed lubricator data plates. Reference Section 1 for data plate location and legend illustration. Indicators on the distributor blocks show the rate at which a block is cycling. To adjust, loosen locknut and turn the feed regulator (plunger stroke adjustment screw) on the pump at the lubricator box, until the indicator strokes at the proper rate, seconds per cycle. Reference Section 5 lubricator box chain sprocket illustration for component legend. Re-tighten locknut. Run at this break-in setting for the first 200 hours of operation. The lubricator cycle time may then be increased to the normal operating rate. Reference Section 4 for more information on force feed lube rates.

## Compressor Re-Application

**IF ANY OF THE CONDITIONS LISTED BELOW CHANGE, CONSULT YOUR PACKAGER AND/OR ARIEL FOR ANY HARDWARE AND/OR DOCUMENTATION CHANGES THAT ARE REQUIRED. PERFORMANCE, OPERATING PRESSURES AND LUBRICATION RATE MUST BE RECALCULATED. A TORSIONAL VIBRATION ANALYSIS IS RECOMMENDED.**

- GAS PRESSURES, TEMPERATURES OR FLOW REQUIREMENTS
- GAS PROPERTIES
- DRIVER TYPE, SPEED OR TORQUE
- RE-LOCATION OF COMPRESSOR TO A DIFFERENT SITE
- CYLINDER RE-CONFIGURATION; FRAME OR CYLINDER RE-RATE
- CHANGE OF CYLINDER AND PACKING LUBRICANT TYPE

## SECTION 4 LUBRICATION

### General

Lubrication is vital for successful operation of a compressor. Adequate lubrication of the proper type in the proper place at the proper time is the key to successful lubrication. Although lubrication is an ongoing concern throughout the life of the compressor, the initial package design is very important and deserves special attention.

There are two independent systems for lubricating the compressor; the frame oil system and the force feed system. The frame oil system is a pressurized circulating system that supplies a constant pressurized supply of oil to the crankshaft, connecting rods and crossheads. The force feed system is a low volume high pressure injection system that supplies small quantities of oil at regular intervals to lubricate the piston rod packings and the piston rings. In many applications these two systems can use the same lubricant, but in some applications the lubricants must be different.

### Lubrication Functions

Lubrication performs at least six functions in a compressor.

1. Reduce friction:  
A lubricant decreases the resistance to movement between contacting components. The lubricant allows the components to slide on an oil film rather than directly on the component surfaces to reduce friction.
2. Reduce wear:  
A proper lubricating film minimizes contact between sliding components which reduces wear to increase equipment life expectancy and decrease maintenance costs.
3. Remove heat:  
Frictional heat is generated between the moving parts and the lubricating film. Circulating oil allows for heat removal to maintain working tolerances and extend oil life.
4. Prevent corrosion:  
Keeping air and moisture from the surfaces reduces corrosion to decrease debris particles, frictional heat, and component wear. Corrosion prevention is generally provided by additives rather than the base lubricant.
5. Seal and reduce contaminant buildup:  
A liquid lubricant fills small spaces to improve the gas seal on piston rings and packing rings, and flushes away contaminants from moving parts.
6. Dampen shock:

A lubricant of a proper viscosity helps to cushion shock loads or pulsations to reduce vibration and noise, and increase component life.

# Lubricant Characteristics

## Viscosity

Viscosity is a measurement of the resistance of a fluid to flow. Viscosity measurement is temperature dependent and decreases with increasing temperature. Most commonly used are units of dynamic viscosity, which is expressed in units of Saybolt Universal Seconds (SUS) in English units and by centistoke (cSt) in metric. Proper viscosity is the most important aspect of compressor lubrication. The chart below illustrates the viscosity differences between base stock types.

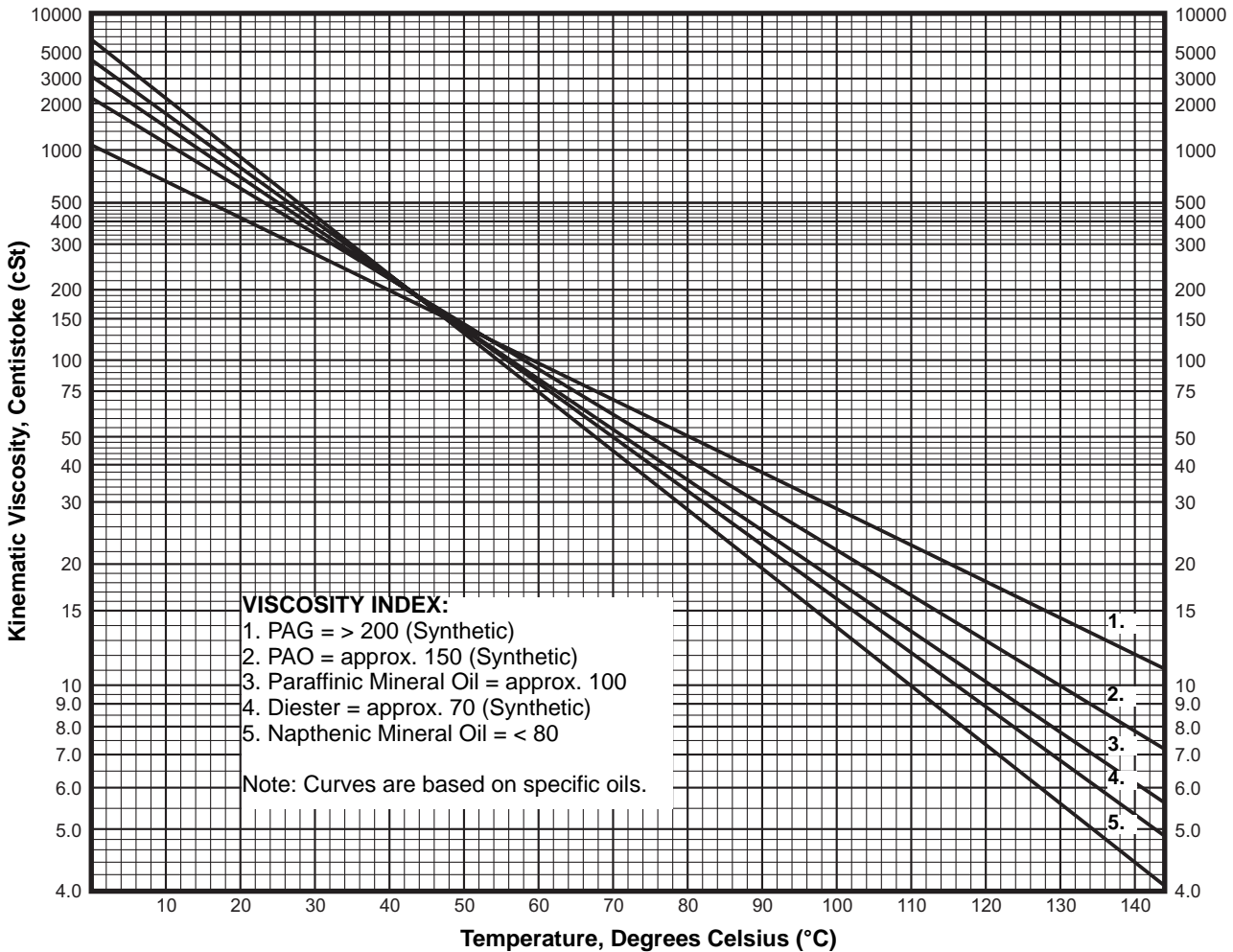


FIGURE 4-1 VISCOSITY VS. TEMPERATURE GRAPH SHOWING DIFFERENT TYPES OF LUBRICANTS

Oil viscosity will increase when the oil begins to oxidize or when it is contaminated with oil or another liquid with higher viscosity. Oil viscosity will decrease when it is contaminated with hydrocarbon gas condensate or another liquid with lower viscosity. Oil will not "break-down"

or "degrade" to a lower viscosity, unless it is a multi-viscosity oil (such as SAE 10w40). In the case of multi-viscosity oils, the viscosity improvers are breaking down, not the base oil itself.

## Viscosity Index

A scale used to indicate the magnitude of viscosity changes with respect to temperature. The higher the viscosity index, the less the viscosity decreases as the temperature increases.

## Pour Point

Pour point is the lowest temperature at which the oil will just barely flow. It becomes very important in cold weather starting applications and in cylinder and packing lubrication with very cold suction temperatures.

## Flash Point

Flash point is the lowest temperature at which the oil will vaporize to create a combustible mixture in air. If exposed to flame, the mixture will flash into flame and then extinguish itself. This is important in high temperature applications when the oil may come in contact with air.

## Lubricant Base Stock

Liquid lubricants commonly used in compressors include petroleum based oils and synthetic fluids. All lubricant formulations start with base stock and lubricant additives are used to improve specific properties such as:

- Increase the viscosity index
- Inhibit oxidation
- Depress the lubricant pour point
- Inhibit rust formation
- Improve detergency
- Provide anti-wear protection
- Provide extreme pressure protection
- Alter the friction characteristics
- Decrease the effects of gas dilution to resist "washing" of the lubricant due to water, wet or saturated gas, or diluent properties of the gas stream.

## Petroleum-Based Lubricants (also referred to as mineral oils)

### PARAFFINIC OILS

- Solvent refined or hydro-treated
- West Texas Intermediate or Arab Light



- Higher wax content
- Viscosity Index, greater than 90
- Pour point around 25°F (-4°C)
- This is the most common mineral oil base stock.

#### **NAPHTHENIC OILS**

- Solvent refined or hydro-treated
- South Louisiana crude
- Lower Wax content
- Viscosity Index, less than 80
- Lower pour point than paraffinic oils
- Better additive solvency

## **Synthetic Lubricants**

Synthetic lubricants are man-made materials with more consistent, controlled chemical structures than petroleum lubricants. This improves predictability of viscosity and thermal stability that results in much higher viscosity indexes than mineral oils. Additives can be used to modify all the common lubrication characteristics to meet or exceed the performance of mineral oils. There are three major types of synthetic fluids used for lubrication. They are commonly referred to as PAO, Diester, and PAG.

**NOTE: Most synthetic lubricants with the proper viscosity are acceptable for use in the compressor frame. Check with your lubricant supplier or Ariel before using ANY lubricant, if you have any questions about the applicability of the lubricant in the frame.**

#### **POLYALPHAOLEFINS (PAO) - SYNTHESIZED HYDROCARBONS**

- Compatible with mineral oils
- Most of the same properties as mineral oils
- Requires additives to improve detergent action and improve seal compatibility
- Soluble in hydrocarbon gases
- High viscosity index, approximately 150
- Low pour point
- High flash point

#### **ORGANIC ESTERS - DIESTERS AND POLYOLESTERS**

- Compatible with mineral oils, PAO and PAG oils
- Incompatible with some rubbers (O-rings), plastics, and paints; compatible with Viton
- Primarily used in air compressors
- Leaves a soft carbon deposit when oxidized
- Breaks down in water
- Higher flash point than mineral oils
- Can be made only to a viscosity of approximately (85-90 cSt at 40°C)
- Higher viscosity achieved with additives or blending with heavier oils
- Low viscosity index, approximately 70

**POLYALKYLENE GLYCOLS (PAG)**

- Very good lubricant for high pressure applications
- Does not foul reservoirs. Excellent for any reinjection application
- Resistant to hydrocarbon gas dilution
- Most are water soluble, verify application with lubricant supplier
- Not compatible with mineral or PAO oils, some plastics and paints
- Requires complete system flush when changing to or from mineral or PAO oils
- Compatible with Viton and HNBR
- Poor inherent oxidation stability and corrosion protection - requires additives
- Not recommended for air compressors.
- Very high viscosity index, greater than 200

**Lubricant Formulations**

Many different oils are made from the same type of base stock by changing the additives. Most oils can be formulated with either a mineral oil base or a synthetic base. The types of additives can significantly alter the lubricant's physical characteristics and suitability for its intended service. Additives can account for up to 30% of the volume of the oil.

**Compounded Cylinder Oils**

Compounded oils are formulated for use in steam cylinders and/or compressor cylinders. These lubricants enhance oil film strength to counter the effects of water, wet gases, solvents, etc., present in the gas.

Additives can be animal or vegetable fats, or synthetic based. Animal and vegetable based additives have a very low oxidation resistance and do not perform well at high temperatures. However, most compounded oils today use some type of synthetic chemical instead of the natural additives. Compounded oil should not be used in the compressor frame. Historically, the additives have not been compatible with lead based bearing materials.

**R&O Oil**

Rust and oxidation inhibited (R&O) oil is a very simple oil comprised of base stock, corrosion inhibitors, anti-wear and antioxidant additives. The viscosity of the base stock determines the viscosity of the finished product. This oil is a very good selection for use in the compressor frame and for most force feed systems.

**Engine Oil**

Engine oil is formulated for use in internal combustion engines. Its purpose is to counteract the negative effects of combustion and help keep the products of combustion (heat, soot, water, CO<sub>2</sub>) away from the moving parts of the engine. It is designed to attract water and soot and help keep it in suspension until it can be removed by the filter. These qualities are

not required in the compressor frame and in fact may prove detrimental to the lubrication of the cylinders and packing.

**ENGINE OIL ADDITIVES MAY INCLUDE:**

- Detergents for removing deposits around the moving parts
- Dispersants for preventing deposits from forming and soot from agglomerating
- Corrosion inhibitors to prevent rust and corrosion
- Antioxidants to neutralize radicals that cause oxidation of the oil
- Anti-wear additives to help prevent metal to metal contact
- Viscosity improvers to improve the viscosity characteristics (primarily for multi-viscosity oil)
- Pour point depressants to reduce the temperature at which the oil solidifies
- Anti-foam agents to help break up foam from air entrainment

Ash is not an additive. It is the heavy metal residue left over when the oil burns. Some of the additives, such as the detergents, dispersants and anti-wear additives contain heavy metals such as calcium (Ca), barium (Ba), magnesium (Mg), phosphorous (P), Zinc (Zn) or sodium (Na). When the oil is burnt on hot parts of the engine, these heavy metals are left behind and build a barrier that helps prevent wear such as valve seat recession.

Engine oil will work satisfactorily in the compressor frame and in many force feed systems in gathering or transmission applications since viscosity is the most important aspect of compressor lubrication. Although engine oil is generally not the best choice for compressor lubrication, operational aspects such as previous experience, inventory control, or simplicity of maintenance practices may outweigh the benefits of using a different type of oil.

**EMULSION**

One common problem with engine oil is the formation of emulsions in the compressor and/or downstream equipment. The detergents in the oil allow the oil and water to mix. If the gas contains enough water, it will mix with the detergents in the oil and emulsify. Usually the emulsions will accumulate in the downstream equipment such as the scrubbers, but can also be found in the cylinders and coolers.

To eliminate an emulsion problem, the emulsions must be completely removed and all equipment thoroughly cleaned. Re-start the compressor using a R&O oil or some other appropriate non-detergent based oil.

**Used Engine Oil**

If used engine oil is supplied for lubrication of the cylinders and packings, it must meet the listed requirements for cylinder and packing lubrication. The oil must be appropriately filtered ( $\beta_5=10$  and  $\beta_{12}=75$  and have an ISO 4406 cleanliness code of 17:16:14 ). Oil viscosity must be monitored and tested to be sure of adequate quality.

**Gear Oil**

Gear oils are formulated for use in gear boxes or other components where components make frequent contact (boundary lubrication). The primary difference between these and other oils is the extreme pressure (EP) additives. The EP additives are usually sulfur or

phosphorous based chemicals that bond with the iron and creates a material that has a low melting point. When the components contact each other, the new material easily breaks away to reduce wear.

The reaction of forming the new material takes place at very high local temperatures. These high temperatures are non existent in the compressor and therefore, the compressor does not need gear oil. However, it is commonly used in instances where a high viscosity oil is required such as ISO 460 or ISO 680.

If gear oil is used in the frame, it will be necessary to be sure the additives are not corrosive to lead or copper based bearing materials.

## FRAME OIL SYSTEM

### COMPONENTS

#### Oil Strainer

An oil strainer, installed upstream of the pump will prevent very large particles and objects from getting into the pump. Ariel supplies a 30 mesh (595 microns) strainer on all JGM:N:P:Q:JG:J:A:R:W:H:E:K:T compressors and a 40 mesh (400 microns) strainer on all JGC:D:U:Z:B:V, KBB:V compressors.

#### Oil Pump

The oil pump constantly supplies oil to all the journal bearings, bushings and crosshead sliding surfaces. The pump is direct coupled to the crankshaft by a chain and sprocket and is designed to provide adequate oil flow to the bearings when the compressor is operating at one-half of maximum rated speed.

The compressor frame driven lube oil pumps maintain oil pressure with a spring loaded regulating valve within the pump head (some models have a separate pressure regulator). Lube system pressure can be raised or lowered by adjusting the spring tension on this valve.

#### Oil Cooler

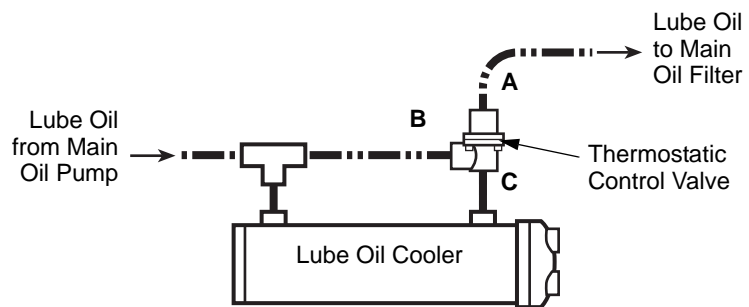
An oil cooler is required and the packager is responsible for sizing the oil cooler. Ariel can supply the oil cooler as a purchased separately item. Factors that must be taken into account while sizing a cooler, are the cooling medium, cooling medium temperature, cooling medium flow rate, lube oil temperature, and lube oil flow rate. Oil heat rejection data for each frame is available in the Ariel Electronic Data Book (contact your Packager or Ariel when you need this information). The Data Book also specifies the required flow rate and temperature of cooling water necessary to properly cool the oil with Ariel supplied coolers. Insufficient cooling water flow rate is the primary cause of high oil temperatures.

The cooler should be mounted as close to the compressor as possible, with piping of adequate size to minimize pressure drop of both the lubricating oil and the cooling medium.

## Oil Temperature Control Valve

Thermostatic valves are required in conjunction with the cooler to control the oil temperature in the compressor. The thermostatic valve is a three way valve that has a temperature sensitive element. As the oil is heated the sensing element will open the third port in the valve.

There are two configurations for installing a thermostatic valve: diverting mode and mixing mode. Ariel recommends installation of the thermostatic valve in the mixing mode. In the mixing mode, as the oil heats up, the element opens a port in the thermostatic valve that allows oil from the cooler to mix with the hot oil from the bypass. In the diverting mode, the oil is diverted to the cooler when the oil from the compressor is hot enough to open the valve. The diverting mode monitors the temperature of the oil coming out of the compressor. The mixing mode monitors the temperature of the oil going into the compressor.



Thermostatic control valve configuration may vary from this schematic, depending on valve size. In mixing mode, B connection is lube oil from main oil pump with tee connection to lube oil cooler inlet, C is from lube oil cooler outlet and A is to main oil filter. Valve connections A-B-C are marked on the valve.

**FIGURE 4-2 LUBE OIL THERMOSTATIC VALVE IN MIXING MODE**

## Oil Filtration

Oil filters are required on all compressor frames to remove contamination that can damage the equipment and contamination that can damage the oil.

Contaminants that damage the equipment can be:

- Wear particles from the equipment
- Airborne particles such as dust or sand
- Solid particles from the gas stream
- Dirt from new oil from the refinery

Contaminants that damage the oil can be:

- Soot (commonly from combustion in an engine)
- Oxidized oil components
- Air bubbles

The JGC/4, JGD/4, JGU/4, JGZ/4, JGB/4, JGV/4, KBB/4, KBV/4, JGE/6, JGK/6, JGT/6, JGC/6, JGD/6, JGU/6, JGZ/6, JGB/6, JGV/6, KBB/6 and KBV/6 compressors are equipped with simplex, cartridge style pleated synthetic type filters as standard. Cartridge filters are rated as 1 micron nominal and 12 micron absolute filters. The Beta ratings are  $\beta_1 = 2$ ,  $\beta_5 = 10$  and  $\beta_{12} = 75$ .

All other Ariel frames are equipped with simplex, spin-on resin-impregnated type filters as standard. Spin on filters have a 5 micron nominal and 17 micron absolute rating. The Beta ratings are  $\beta_5 = 2$  and  $\beta_{17} = 75$ .

There are many spin on filters that will fit an Ariel compressor, but very few meet the filtration ratings of Ariel filters. For this reason, Ariel does not recommend after market filters. Exercise caution if an after market filter is installed.

Pressure gauges are provided for monitoring pressure drop across the filter. Differential pressure is the primary indication of a plugged filter.

## Compressor Prelube Pump

An automated compressor pre-lube system is strongly recommended for all Ariel compressors to extend bearing life and reduce operating costs. Compressors that meet any of the following criteria are required to have an automated pre-lube system to provide oil flow prior to start-up:

1. Electric motor driven compressors.
2. Unattended-start compressors, regardless of driver type.
3. All large frame compressor models (JGC, JGD, JGZ, JGU, JGB, JGV, KBB and KBV).

Automated compressor pre-lube systems must be designed and sized to provide 10 psig (0.7 bar<sub>g</sub>) minimum pressure for a minimum of 30 seconds prior to starting, at the inlet to the oil gallery (after the filter), with minimum start-up oil viscosity and maximum allowable filter differential pressure. It is suggested that the prelube pump be sized at approximately 25% of the frame oil pump capacity. Reference Technical Manual, Section 1, Frame Specification Tables for frame oil pump flow rates, or see the Electronic Databook in the Ariel Performance Program. The purpose is to be sure there is oil flow to all bearings and bushings, and the clearances are filled with oil prior to start-up. A start permissive is desirable to sense for minimum required pressure/time at the inlet to the oil gallery.

Automated systems are to provide for shutdown if 35 psig (2.4 bar<sub>g</sub>) oil pressure is not achieved within 10 seconds after the initiation of start-up (from when crankshaft starts to turn). **If a compressor will not start or shuts down at start-up due to low oil pressure, do not attempt to re-start until the cause of low pressure is corrected.**

Engine driven compressors with manual pre-lube pumps are to be adequately pre-lubed prior to starting. If 35 psig (2.4 bar<sub>g</sub>) oil pressure is not achieved within 10 seconds after reaching engine idle speed, shutdown the compressor and correct the cause. Repeat manual pre-lube prior to each cranking for start-up.

Pre-lube pumps are to be located prior to the oil filter. When oil pressure exceeds 35 psig (2.4 bar<sub>g</sub>) at start-up, a low oil pressure shutdown set at 35 psig (2.4 bar<sub>g</sub>) must be active for all compressors.

## Oil Heaters

Frame oil heaters may be needed if the compressor must be started in cold weather applications. Depending on the operational aspects of the compressor, one possible heating mode is to maintain the temperature in the compressor frame to a minimum temperature so that the compressor can be started immediately if needed, see Table 4-4. Another mode is to

heat the oil from ambient to a minimum temperature prior to starting, see Table 4-5. The specific application requirements will determine which heating mode is necessary.

Circulation type heaters are recommended. All compressor models have at least one connection for a heater. Four and Six throw frames have two locations. The maximum allowable wattage per unit area for an immersion heater is 15 W/in<sup>2</sup> (2.3 W/cm<sup>2</sup>). This limit will prevent oil from coking on the heater element and reducing the efficiency of the heater. It will also prevent the coked oil particles from contaminating the remaining oil. JGU:Z, JGB:V and KBB:V models are designed to use circulation heating only.

**TABLE 4-4 HEAT REQUIRED TO MAINTAIN MINIMUM FRAME TEMPERATURE**

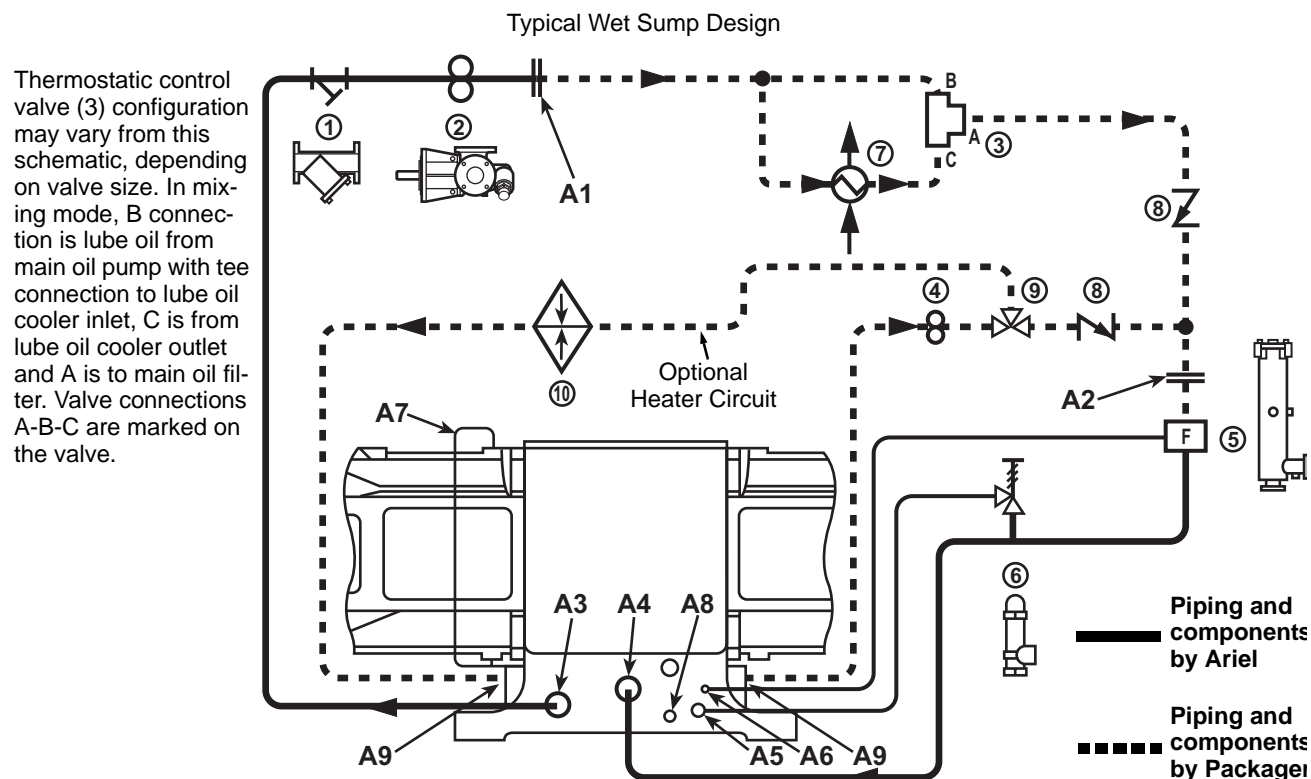
MODEL	MULTIPLY TIMES DIFFERENTIAL BETWEEN OIL & AMBIENT TEMPERATURE					
	2-THROW		4-THROW		6-THROW	
	kW/°F	(kW/°C)	kW/°F	(kW/°C)	kW/°F	(kW/°C)
JGM:N:Q:P	0.0086	(0.0155)	---	---	---	---
JG:A	0.0094	(0.0170)	0.0179	(0.0322)	0.0261	(0.0470)
JGW:R:J	0.0147	(0.0265)	0.0289	(0.0520)	0.0419	(0.0754)
JGH:E:K:T	0.0252	(0.0454)	0.0492	(0.0886)	0.0731	(0.1316)
JGC:D	0.0392	(0.0706)	0.0722	(0.1300)	0.1044	(0.1880)
JGU:Z	0.0534	(0.0961)	0.0944	(0.1700)	0.1319	(0.2374)
JGB:V & KBB:V	---	---	0.1295	(0.2331)	0.1768	(0.3182)

**TABLE 4-5 HEAT REQUIRED TO WARM COLD COMPRESSOR FRAME & OIL**

MODEL	MULTIPLY TIMES TEMPERATURE RISE DIVIDED BY TIME (h)					
	2-THROW		4-THROW		6-THROW	
	kW-h/°F	(kW-h/°C)	kW-h/°F	(kW-h/°C)	kW-h/°F	(kW-h/°C)
JGM:N:Q:P	0.0275	(0.0495)	---	---	---	---
JG:A	0.0352	(0.0634)	0.0818	(0.1472)	0.1347	(0.3425)
JGW:R:J	0.0591	(0.1064)	0.1212	(0.2182)	0.1832	(0.3298)
JGH:E	0.1368	(0.2462)	0.2962	(0.5332)	0.4526	(0.8147)
JGK:T	0.1494	(0.2689)	0.3024	(0.5832)	0.4526	(0.8147)
JGC:D	0.2684	(0.4831)	0.5614	(1.0105)	0.8074	(1.4533)
JGU:Z	0.4496	(0.8093)	0.8900	(1.6020)	1.2421	(2.2358)
JGB:V & KBB:V	---	---	1.4176	(2.5517)	2.0224	(3.6403)

## Lube Oil Analysis Sampling Point

A sampling point should be installed at a convenient location between the oil pump and the filter. This should be installed at an easily accessible location and designed to minimize the amount of dirt or debris that can collect around the dispensing point. A needle valve should be used to better control the flow of the pressurized oil.



**Oil Connections** (See Ariel Outline Drawing for Details)

- A1 Packager Connection from Oil Pump
- A2 Packager Connection to Oil Filter
- A3 Oil Connection from Compressor Crankcase (Oil Sump)
- A4 Lube Oil Compressor-Inlet-Connection to Gallery Tube. Oil Flows to the Crankshaft Main Bearings and through Drilled holes in the Crankshaft to Connecting Rod Bearings, then through Drilled Holes in the Connecting Rods to the Crosshead Pins and Crosshead Bushings.
- A5 Pressure Regulating Valve return Connection to Oil Sump, when applicable.
- A6 Filter Vent return Connection to the Oil Sump, when applicable on some models
- A7 Oil tubing connections from Frame Gallery Tube to top and bottom of the Crosshead Guides to lubricate Crossheads
- A8 Compressor Crankcase Oil Drain (Oil Sump Drain)
- A9 Pre-Lube/Recirculation/Heater Connections (4)

**System Components**

- 1. Y - Strainer
- 2. Compressor Driven Oil Pump (w/ Safety Relief Valve - used as a pressure regulating valve, or for models with a separate regulating valve (6), as a relief valve)
- 3. Thermostatic Control Valve, 170°F (77°C) nominal rating - Required (available as an purchase separately from Ariel)
- 4. Pre-Lube Oil Pump - Required (shown with Oil Heating Circuit, when applicable)
- 5. Oil Filter
- 6. Pressure Regulating Valve (with Overflow Return to Oil Sump), when applicable.
- 7. Oil Cooler - Required
- 8. Check Valve
- 9. 3-Way Valve, when applicable for Heater Circuit
- 10. Heater (When Applicable)

**FIGURE 4-3 STANDARD FRAME LUBE OIL SCHEMATIC - TYPICAL**

## Cold Starting

If a compressor is exposed to cold ambient temperatures, the oil system must be designed so the unit may be safely started with adequate oil flow to the journal bearings. Temperature controlled cooler by-pass valves, oil heaters, cooler louvers and even buildings may be needed to ensure successful operation.



## Dry Sump

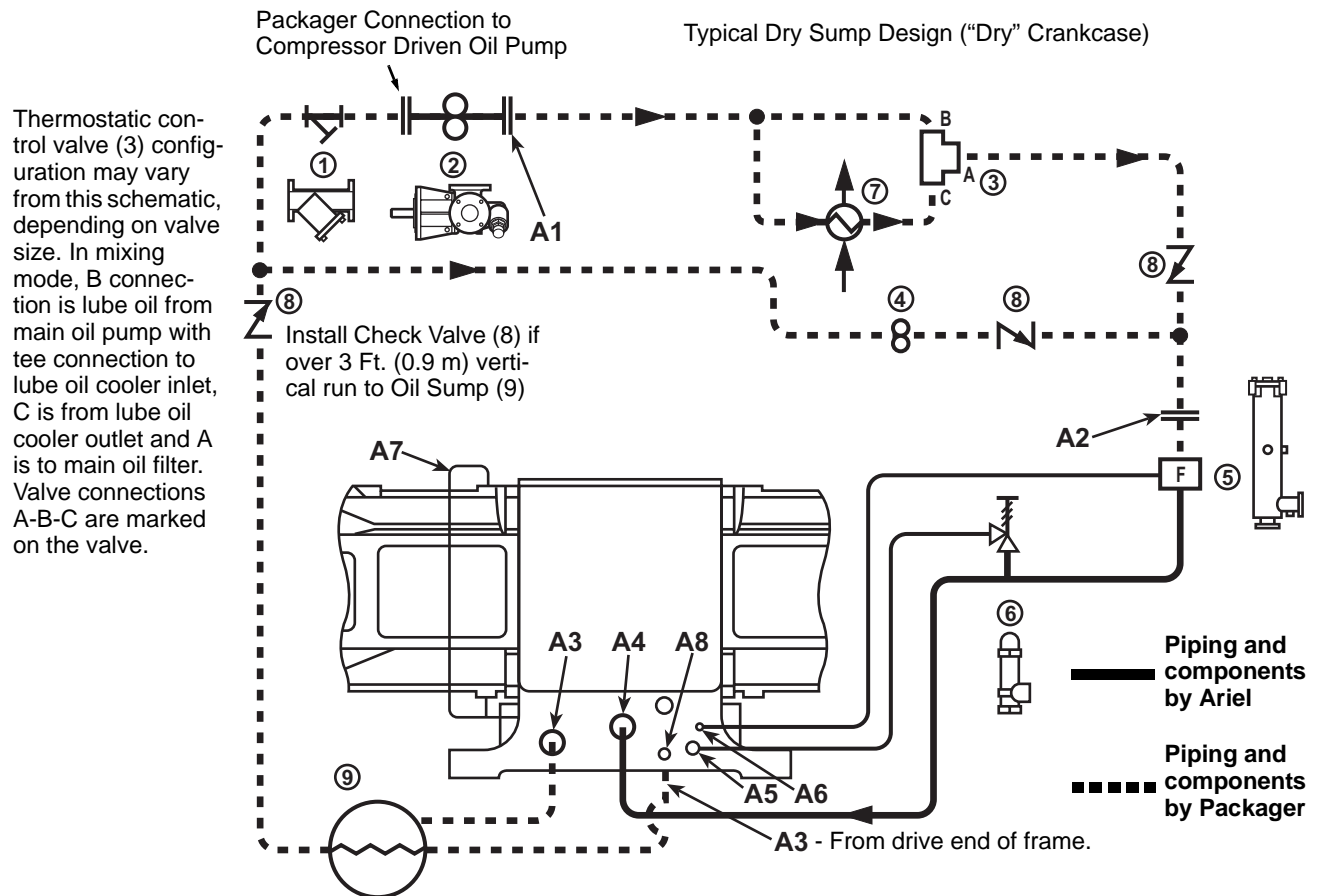
Compressors subject to transient motion, roll and yaw on board a ship or a floating platform, may require a dry sump (“dry” crankcase and separate oil reservoir). See the table for limits, which are based on the angle where the crankshaft/connecting rods will contact the oil level causing foaming. The limits assume that the running oil level is maintained between one half and two-thirds the height of the sight glass when the frame is perfectly level.

With a dry sump, drains are supplied at each end of the compressor frame and an additional oil pump chain oiler is provided by Ariel. The packager must provide a lube oil reservoir sized and located so that the oil pump has oil suction regardless of the tilt of the ship or floating platform. An oil sump strainer must be installed in the pump suction line at the outlet of the separate lube oil reservoir (unmounted strainer is provided by Ariel with a new dry sump compressor). Refer to the Ariel outline drawings for connection sizes and locations.

**TABLE 4-6 MAXIMUM ANGLE FROM HORIZONTAL ALLOWED IN TRANSIENT MOTION WITHOUT DRY SUMP**

FRAME <sup>A</sup>	THROWS		
	1 OR 2	4	6
JGM:N:P:Q	4°	N/A	N/A
JG	4°	2.5°	N/A
JGA	6.5°	3.5°	2°
JGW:R	1°	Use Dry Sump <sup>b</sup>	N/A
JGJ	4°	1°	Use Dry Sump <sup>2</sup>
JGH	3.5°	2°	N/A
JGE:T	4°	1.5°	1°
JGK	1°	Use Dry Sump <sup>2</sup>	Use Dry Sump <sup>2</sup>
JGC	4°	1°	Use Dry Sump <sup>2</sup>
JGD	5.5°	2.5°	1°
JGZ:U	7°	4°	2.5°
JGB:V	N/A	2°	1.5°
KBB:V	N/A	1.5°	1°

- a. The JGI frame, vertical non-balanced compressor, is not to be applied offshore.
- b. Use dry sump, as noted, if compressor is to be subject to transient motion.



**Oil Connections** (See Ariel Outline Drawing for Details)

- A1 Packager Connection from Compressor Driven Oil Pump
- A2 Packager Connection to Oil Filter
- A3 Packager Connection - Oil from Compressor Crankcase
- A4 Lube Oil Compressor-Inlet-Connection to Gallery Tube. Oil Flows to the Crankshaft Main Bearings and through Drilled holes in the Crankshaft to Connecting Rod Bearings. From there, through Drilled Holes in the Connecting Rods to the Crosshead Pins and Crosshead Bushings.
- A5 Pressure Regulating Valve Return Connection to Crankcase, when applicable on some models
- A6 Filter Vent Return Connection to the Crankcase, when applicable on some models
- A7 Oil Tubing Connections from Frame Gallery Tube to Top & Bottom of the Crosshead Guides to Lubricate Crossheads
- A8 Compressor Crankcase Oil Drain

**System Components**

- 1. Y - Strainer - Required (supplied unmounted by Ariel)
- 2. Compressor Driven Oil Pump (w/ Safety Relief Valve - used as a pressure regulating valve, or for some models when a separate regulating valve (6) is provided, as a relief valve)
- 3. Thermostatic Control Valve, 170°F (77°C) nominal rating - Required (available as an option from Ariel)
- 4. Pre-Lube Oil Pump - Required (with oil heating circuit when applicable)
- 5. Oil Filter
- 6. Pressure Regulating Valve (w/ Overflow Return to Crankcase), when applicable for some models
- 7. Oil Cooler - Required
- 8. Check Valve
- 9. Separate Lube Oil Reservoir (Oil Sump) - Required

**FIGURE 4-4 OPTIONAL DRY-SUMP FRAME LUBE OIL SCHEMATIC - TYPICAL**

## FRAME OIL OPERATING CONDITIONS

### Compressor Frame Lubricant

Ariel recommends for use in the compressor frame, an ISO 150 grade paraffinic mineral oil that provides oxidation inhibition, rust and corrosion inhibition, and anti-wear properties. This is commonly called R&O oil.

SAE 40 wt engine oil is also acceptable in the frame, but contains significant amounts of additives that are not necessary in a compressor.

In limited circumstances and with prior approval from Ariel, cold weather installations may use multi-viscosity oils in the compressor frame if the oil supplier can certify that the oil is shear stable. The viscosity of shear stable oil degrades less through use. Most oil suppliers will certify their oil as shear stable if the viscosity degrades less than a certain percentage in specific tests. As a result, multi-viscosity oils are subject to a shorter oil life than single straight grade oils by 30% to 50%.

Synthetics such as PAG, PAO, or ester based lubricants are acceptable in the compressor frame provided they meet the operating viscosity requirements as outlined below.

Compounded lubricants are prohibited in the frame.

## Oil Viscosity

The minimum allowable viscosity of the oil going into the frame is 82.6 SUS (16 cSt). Typically this is the viscosity of ISO 150 grade oil at about 190°F (88°C).

The maximum viscosity of the lube oil for cold ambient temperature starting is 15,000 SUS (3300 cSt). Typically this is the viscosity of ISO 150 grade oil at about 25°F (-4°C).

## Oil Pressure

Normal pressure on the discharge side of the lube oil filter is factory set for 60 psig (4.1 bar<sub>g</sub>) for compressors that were tested mechanically complete (has inspector tag). If tested at factory as mechanically incomplete (without inspector tag), normal oil pressure must be set by packager or at initial start-up to 60 psig (4.1 bar<sub>g</sub>) at full rated speed and normal operating temperature. If the lube oil pressure drops below 50 psig (3.4 bar<sub>g</sub>), the cause should be found and corrected. A low lube oil pressure shutdown, set at 35 psig (2.4 bar<sub>g</sub>), is required for protection of the compressor during a sudden loss of oil pressure. The compressor should not operate for prolonged periods of time at less than 50 psig (3.4 bar<sub>g</sub>) oil pressure.

For proper operation of the thermostatic control valve, the maximum differential pressure between the hot oil supply line and the cooled oil return line is 10 psid (0.7 bar<sub>d</sub>).

## Oil Temperature

The minimum lube oil operating temperature is 150°F (66°C). This is the minimum temperature required to drive off water vapor.

Maximum allowable oil temperature into the compressor frame is 190°F (88°C).

A thermostatic control valve supplied by Ariel is set at 170°F (77°C). The oil temperature should be maintained as close to this temperature as possible. Higher temperatures increase the oxidation rate of the oil. For every 18°F (10°C) over 150°F (66°C), the oxidation rate of the oil doubles.

## Oil Maintenance

Compressor frame lubricating oil should be changed as indicated in the regular maintenance intervals or with a filter change or when oil analysis results indicate the need. A more frequent oil change interval may be required if operating in an extremely dirty environment without sampling and analysis or if the oil supplier recommends it.

## Oil Sampling

Oil samples should be collected on a regular basis and analyzed to verify suitability of oil for continued service. Consistent oil analysis can identify when to change the oil on the basis of need rather than on a scheduled interval. Depending on the service, the length of time between oil changes can be significantly extended through oil analysis. Oil analysis should include:

- Viscosity testing should be performed at 100°F (40°C) and 212°F (100°C). This is to be sure that the oil has not mixed with cylinder oils or process gas.
- Particle counting to the latest version of ISO 4406.
- Spectroscopy to determine wear metals, contaminants, and additives.
- FTIR (Fourier Transform Infrared Spectroscopy) to check for oxidation, water or coolant contamination, and additive depletion. This is more important if a separate lube oil is used for the force feed system.

## Oil System Cleanliness

The compressor frame oil piping system and components are to be free of foreign matter including, but not limited to dirt, sand, rust, mill scale, metal chips, weld spatter, grease and paint. It is recommended that a commercial pipe cleaning service be used to clean the oil piping system. If that is not practical, proper cleaning procedures using cleaners, acids, and/or mechanical cleaning are to be used to meet the cleanliness requirements. Cleaning by-products are to be properly disposed; a disposal service is recommended. It is also recommended that all oil-piping systems be flushed using an electric or pneumatic driven pump and filtered clean production oil. All compressor frame cavities are thoroughly cleaned prior to assembly and compressors are test run with a filtered closed loop lube system at the Ariel factory.

**Note:** Ariel recommends that the lube oil piping downstream of the installed oil filter not be disturbed as contaminants that enter that piping or open ports will be flushed into the bearings causing catastrophic damage. If the piping must be removed or altered, great care must be taken to cover the inlets to the oil galley, the ends of the piping, and the filter outlet so that no contaminants may enter. Before reinstallation, chemical and mechanical cleaning is required. The pipe must then be flushed in accordance with Ariel's stated cleanliness requirements.

For all compressors that are installed with an electric or pneumatic powered pre-lube pump, which have less than 50 feet (15 m) of oil piping are to be flushed as follows, prior to starting the compressor. The cooler oil passages are to be included in the flushing loop. Oil systems for compressors without an electric or pneumatic powered pre-lube pump, which have less

than 50 feet (15 m) of oil piping, must be clean and while oil flushing is desirable for these systems, it is not a requirement.

Prior to assembling the lube oil piping remove scale, weld slag, rust and any other matter that could contaminate the lube oil.

Confirm:

- The entire lube oil system is complete and closed.
- The crankcase is filled to the correct level with the appropriate oil.
- The proper lube oil filters are installed correctly.
- The oil pressure transducer or gauge, oil filter differential-pressure transducers or gauges, and oil temperature RTD or indicator are operational & values are viewable.

Start the pre-lube pump, record the oil pressure, oil filter differential-pressure and oil temperature. Minimum measured oil pressure should be 30 psig (2.1 bar<sub>g</sub>) for effective flushing. Do not exceed 90 psig (6.2 bar<sub>g</sub>).

A continuous hour of pre-lube flushing time must be achieved with an oil filter differential-pressure increase less than 10% of the measured oil pressure into the filter. Record the oil pressure, oil filter differential pressure and oil temperature at 15 minute intervals. If the oil temperature increase is greater than 10°F (5.5°C) during an hour of flush time, it is not a valid test of system cleanliness, due to oil viscosity change.

If the differential pressure or temperature increases exceed the limits in the paragraph above, after an hour of pre-lube flushing, continue the flushing operation. Whenever the lube oil filter differential pressure exceeds the change filter limits, stop the pre-lube pump and change the oil filter. Re-set time and continue the flushing operation until a continuous hour of flushing time is achieved within the differential pressure and temperature increase limits to ensure system cleanliness.

For all compressors with an oil piping system greater than 50 feet (15 m), cleaning and flushing must result in a cleanliness level to ISO-4406, Grade 13/10/9 and/or NAS-1638, Class 5 (reference table), prior to starting the compressor.

See table and ISO-4406 "International Standard - Hydraulic fluid power - Fluids - Method for coding level of contamination by solid particles" and/or NAS-1638 "National Aerospace Standard, Aerospace Industries Association of America, Inc. - Cleanliness Requirements for Parts Used in Hydraulic Systems" for complete information. Utilize a competent oil laboratory for sample testing.

**TABLE 4-7 OIL FLUSHING CLEANLINESS REQUIREMENTS**

ISO-4406 Grade 13/10/9		
Grade Requirements	Particle Size µm/mL Oil Sample	Number Particles Allowed
/13	Greater than 4	40 to 80
/10	Greater than 6	5 to 10
/9	Greater than 14	2.5 to 5
NAS-1638 Grade 5		
Particle Size Range µm/100mL Oil Sample	Grade 5 Maximum Number Particles	
5 to 15	8,000	
15 to 25	1,424	
25 to 50	253	
50 to 100	45	
Over 100	8	

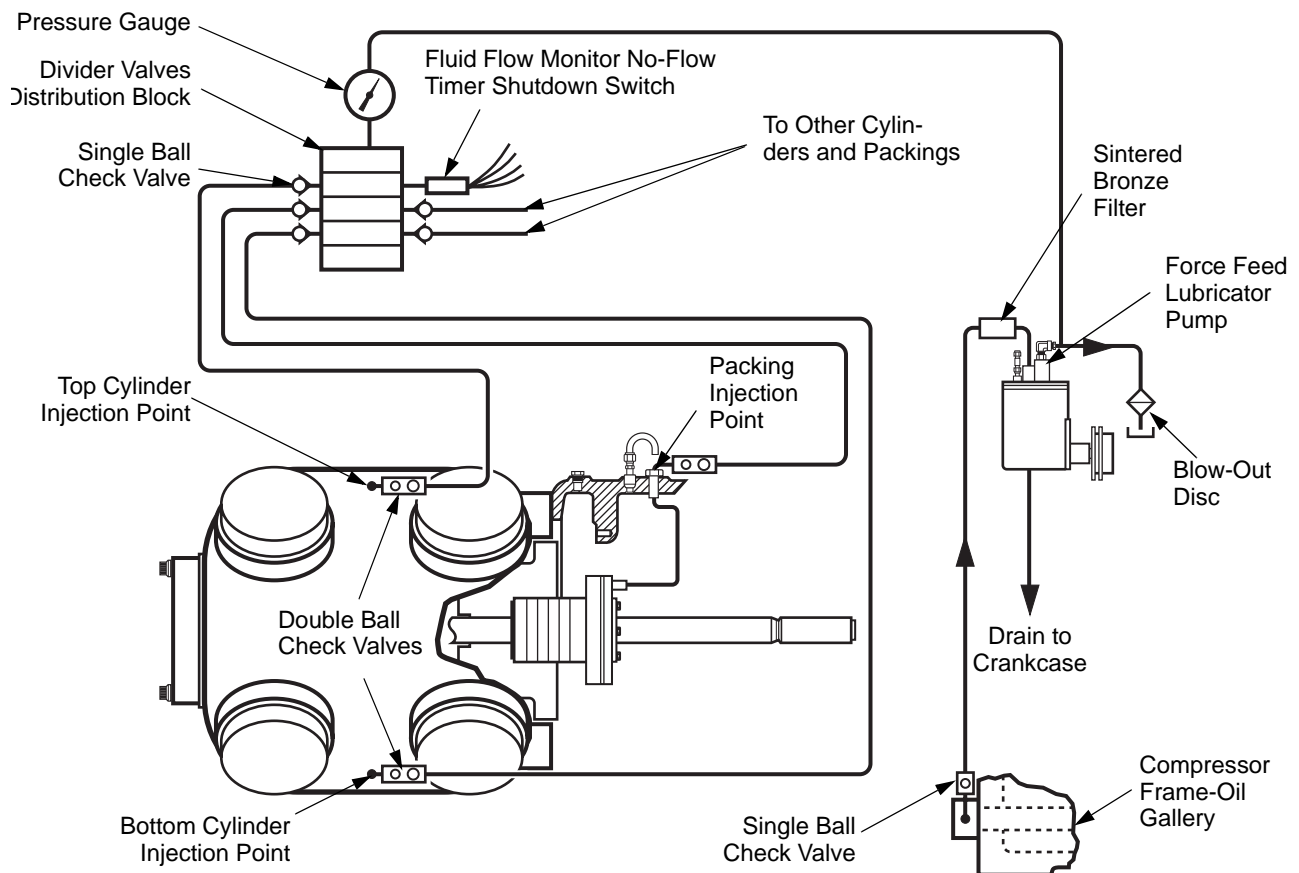
# Cylinder and Packing Lubrication

## Independent Force Feed Lubricator Systems

The cylinders and packing require an oil supply with a viscosity below 5000 SUS (1100 cSt) at the lubricator pump inlet. Measures which may be necessary to make sure that the force feed pump is filled with oil during the suction stroke include; appropriate pipe and fitting size from the tank to the force feed pump, heating the oil, and pressurizing the supply tank.

## Common Oil Supply

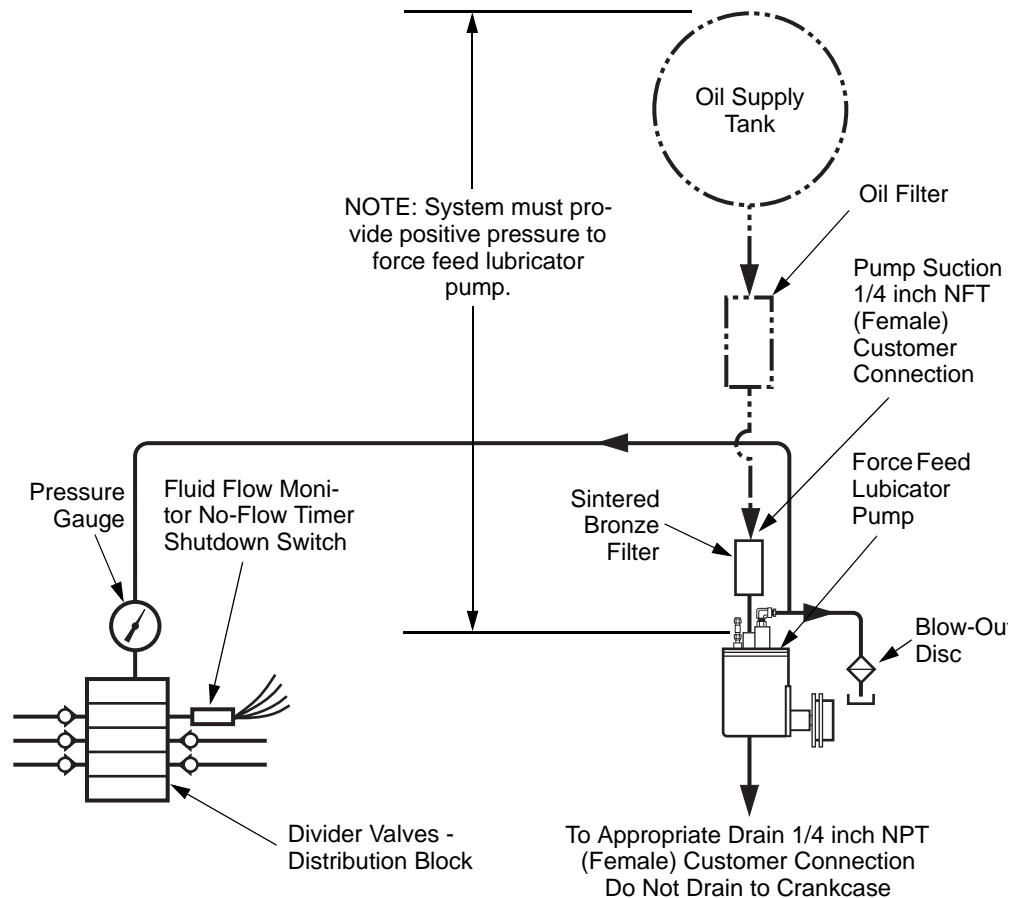
When process gas composition and cylinder operating conditions allow compressor frame lubricating oil to be used for cylinder and packing lubrication, the resulting force feed lube systems are installed as shown in Figure 4-5.



**FIGURE 4-5 FORCE FEED LUBRICATION SYSTEM - COMMON OIL SUPPLY**

## Independent Oil Supply

When process gas composition and cylinder operating conditions require an independent cylinder and packing oil supply, the resulting separate force feed lube systems require an oil supply. Lubricator oil is supplied under pressure from an elevated tank. To prevent the compressor frame oil from being contaminated by the force feed oil, be sure that the lubricator box over flow does not drain into the crankcase. The lubricator box over flow tubing must be disconnected from the compressor frame and directed to an appropriate drain system.



**FIGURE 4-6 FORCE FEED LUBRICATION SYSTEM - INDEPENDENT OIL SUPPLY**

Independent force feed lube systems require oil with a viscosity below 5000 SUS (1100 cSt) at the lubricator pump inlet. Measures which may be necessary to make sure that the force feed pump is filled with oil during the suction stroke include; appropriate pipe and fitting size from the tank to the force feed pump, heating the oil, and pressurizing the supply tank. An in-line oil filter or fine screen is required between the supply tank and the force feed lubricator pumps. Recommended filtration is 5 micron nominal.

## Force Feed Lubrication System Components

### Gas Inlet Debris Screens to Maintain Lube Performance

Even when the proper rate and lubricating medium are in use, dirt and foreign matter in the gas will prevent the lubricant from performing properly. Prior to start-up, cone type inlet gas debris strainers with 100 mesh per inch (150 micron) screen and perforated metallic backing are to be installed in a pipe spool between the inlet scrubber and cylinder suction flange. In

order to protect the compressor cylinder, any piping or vessels downstream of the screen must be thoroughly cleaned to be sure that no debris is present. Proper maintenance of the inlet screens is required. Inlet debris strainers should be monitored by differential pressure and cleaned before the differential pressure approaches the collapse pressure of the screens.

High differential pressure alarm/shutdown switches can be used to protect against screen collapse.

## Injection Oil Inlet Filter

An in-line oil filter or fine screen is required between the oil supply or supply tank and the force feed lubricator pumps. Ariel recommended filtration is 5 micron nominal. The compressor filtration system is adequate for systems that use frame lube oil for the force-feed cylinder and packing injection. For separate force-feed lube oil supplies, a filter must be installed by the packager.

## Oil Dilution

Cylinder lubrication requirements will vary with the operating conditions and the composition of the gas to be compressed. Careful consideration must be given to proper cylinder lubrication selection. The degree of cylinder oil lubrication dilution/saturation by the process gas stream is influenced by the following factors:

1. Process gas composition/Specific Gravity (SG) - usually the higher the SG, the greater the oil dilution.
2. Discharge gas pressure - the higher the pressure, the greater the oil dilution.
3. Discharge gas temperature - the higher the cylinder discharge temperature, the less the oil dilution.
4. Lubricant selection - some types of oil are more prone to dilution than others.

## Cylinder Oil Lubrication Examples

Refer to Table 4-9 for lubrication recommendations for various gas compositions and various operating conditions. Note that lubrication rates can change with operating conditions. Lubricating oil type will also vary with the composition of the gas which is to be compressed.

Independent force feed lube systems require oil with a viscosity below 5000 SUS (1100 cSt) at the lubricator pump inlet. Measures which may be necessary to make sure that the force feed pump is filled with oil during the suction stroke include; appropriate pipe and fitting size from the tank to the force feed pump, heating the oil, and pressurizing the supply tank.

## Under/Over Lube

**Inadequate** - (under) lubrication. This condition results in extremely rapid breakdown of piston and packing ring materials. Black, gummy deposits which can be found in the distance piece, packing case, cylinder and valves are indicators of under lubrication.



**Excessive** - (over) lubrication can result in excessive oil carryover into the gas stream, and increased quantities of deposits in the valves and gas passages. Valve plate breakage and packing failure may also be symptoms of over lubrication.

## Inadequate Lubrication Symptoms

When observed symptoms indicate inadequate lubrication; first verify that the force feed lubricator pumps are operating properly. Confirm that the distribution block cycle time matches the lube sheet or lubrication box information plate provided by Ariel, and double check that all tubing and fittings are tight and no leaks are present. Do not overlook the fittings inside the cylinder gas passages. Pressure test or replace divider valves to be sure they are not bypassing.

## Lubrication Quantity - Paper Test Method

To check cylinders for the proper lubrication rates, the cigarette paper test method can provide a practical indication. Relieve and vent all pressure from all cylinders. Remove the head end head and position piston at about inner center, for the cylinder to be checked. "Lock out" so that crankshaft can not be accidentally turned; see the "CAUTION" in Technical Manual Section 5 and refer to the Packager's Operation Manual for details. Use two layers of regular unwaxed commercial cigarette paper, together. Wipe the cylinder bore at top with both papers using light pressure in circumferential motion through about 20°. The paper next to the bore should be stained (wetted with oil), but the second paper should not be soaked through.

Repeat the test at both sides of the bore at about 90° from the top, using two new clean papers for each side. When the paper next to the bore is not stained through, it may be an indication of under lubrication. When both papers are stained through, it may be an indication of over lubrication. In either case, it is normally recommended that the lubrication rate be changed accordingly and that all cigarette paper tests be repeated until passed. Repeat for all cylinders. If a reduction or increase of the lubrication rate is indicated for a cylinder, change in 5% increments by adjusting cycle time at the force feed lube pump as discussed in "Force Feed Lubricator Adjustment" in Technical Manual Section 3. Repeat oil film testing, for the cylinders affected, after 24 hours of operation.

**NOTE: THE CIGARETTE PAPER TEST ONLY GIVES AN INDICATION OF OIL FILM QUANTITY. AFTERMARKET DEVICES THAT MEASURE FLOW ARE ALSO AVAILABLE. NEITHER METHOD GIVES AN INDICATION OF VISCOSITY QUALITY. OILS DILUTED WITH WATER, HYDROCARBONS OR OTHER CONSTITUENTS MAY PRODUCE WHAT APPEARS TO BE AN ADEQUATE FILM OR FLOW. BUT THE OIL FILM MAY NOT HAVE THE REQUIRED LOAD-CARRYING CAPABILITY DUE TO THE DILUTION.**

## Lubricator Cycle Time

The lubricant flow rates (measured in seconds per cycle) are generally so low that all of the required flow to a lube point may be observed as a drip at a loosened supply fitting. The break-in and normal lube timing rates which are stamped on the lubricator box information

plate are calculated according to the Ariel Lube Specifications, as given in this document, to match the gas and operating conditions as supplied to Ariel with the compressor order. The lube sheets supplied in the Ariel Parts Book state gas conditions and list the base rate multiplier at each lube point. If gas conditions were not supplied with the compressor order, the information plate/lube sheets rates are for clean, dry, 0.65 specific gravity, sweet gas at rated speed and discharge pressures.

If the compressor operating conditions change (such as gas properties, gas pressures, temperatures or flow requirements or cylinder re-configuration) the lubrication rates must be recalculated and hardware changes may be necessary to the force-feed lubrication system. Consult Table 4-9 and your Packager and/or Ariel.

## Cycle Time Indication

To set the proper force-feed lubricator pump flow rate, read the cycle time on the Proflo electronic lubricator fluid-flow monitor/no-flow timer switch located at the distribution block or in control panel, reference Technical Manual Section 5. Or if a digital no-flow timer switch (DNFT) is provided, time the cycle from flash to flash, or for a magnetic cycle indicator assembly, time the cycle from initial movement of the indicator pin at the fully retracted position to the time when the pin returns to the fully retracted position and just begins initial movement back out again. Adjust the lubricator pump to provide the required cycle time-flow rate.

**NOTE: WHEN ADJUSTING THE FORCE FEED LUBRICATION PUMP SETTING FOR THE APPROPRIATE CYCLE TIME, DO NOT SET THE FLOW RATE TOO LOW. THE PUMPS CAN BECOME INCONSISTENT WHEN SET TOO LOW.**

## Force Feed Lubrication System Monitoring:

### Minimum Requirements

Ariel requires the unit control panel to shutdown the unit if the master lube distribution block stops cycling while the compressor is running. The control panel is to wait for a maximum time of 3 minutes after the distribution block stops cycling to issue the shutdown. This is a class B shutdown. A class B shutdown is defined as a shutdown that is not armed until a short time after the compressor is started. Typically 2 minutes. This gives the divider blocks time to cycle the first time before the shutdown is activated.

### Devices

Ariel offers several devices that can be used to obtain the lube system shutdown. There are two basic types. Note that some devices have both functions built in.

## Choosing a Lube System Monitor

When ordering an Ariel compressor the packager must choose a lube system monitor. See the following table for the specifications on available types. For further information about each device visit the vendor literature section of the Ariel web site.

**TABLE 4-8 FORCE FEED LUBE SYSTEM MONITORS - SPECIFICATIONS**

ITEM	PROFLO	KENCO	DNFT	DNFT - PROGRAMMABLE
Shutdown Signal	YES	NO	YES	YES
Proximity Signal	YES (0.5 sec pulse)	YES (switch)	YES (switch)	YES (switch)
Local Data Storage	YES	NO	NO	Count Display
Infrared Port	YES	NO	NO	NO
PLC Creates Shutdown	NO	YES	NO	NO
Remote Mounting	YES	NO	NO	NO
Area Classification	CSA	CSA	CSA, CE, EX, ATEX	CSA, CE
CSA	203633 Class I, Div 2, Groups ABCD T4A	044787 Class I, Groups ABCD: Class II, Groups EFG: Class III	108334 Class I, Div 1 Groups ABCD T5; &/or Class I, Zone 1 Ex md IIC T5	108334 Class I, Div 1 Groups ABCD T5; &/or Class I, Zone 1 Ex md IIC T5
CE	N/A	N/A	0344 Class I Div 1; Groups ABCD T4	0344 Class I Div 1; Groups ABCD T4
EX	N/A	N/A	II 2G EEx mIIB T5	N/A
KEMA	N/A	N/A	00ATEX1090X/AMB. -40°C to +85°C	N/A
Battery	(2) Standard Alkaline "AA" Size	None	Ariel P/N A-10807	Ariel P/N A-10807
Cost Factor New Unit	\$0 Standard	Minus \$	\$0 Standard for CE	Plus \$
Shutdown Time	Programmable	PLC	3 minutes	Programmable 20 sec. to 4 minutes
Temperature	to 185°F (85°C)	to 220°F (104°C)	-40°F to +185°F (-40°C to +85°C)	-40°F to +185°F (-40°C to +85°C)
Max. Switch Voltage	36 VDC	200 VAC/VDC	240 VDC	10 to 120 VAC
Max. Switch Current	0.5 Amps	0.5 Amps	N/A	N/A
Max. Switch Power	N/A	10 Watts DC	2.5 VA	2.5 VA
Local Cycle Indicator	YES - LCD	Separate Indicator	YES - Flashing LED	YES - LCD Display +LED
De-bounce Included	NO	NO	YES	YES

I. **Shutdown switch** - This is a device that monitors the position of the divider block pin and supplies a shutdown contact. If the divider block stops cycling for a given time a shutdown signal will be sent to the control system.

**APPLICATION NOTES - Shutdown Switch**

**Normally open (NO) vs. Normally closed (NC) Shutdown switch**

Divider block monitoring devices define their operation opposite from other industries. Most other industries define the switch state as the state the switch is in when it is on the shelf. (That is: If a momentary push button switch is NO, then when it is taken out of the box the switch will be open until the button is pushed and the contact will close. If a momentary push button switch is NC then when it is taken out of the box the switch will be closed until the button is pushed.) This does not apply to divider block monitoring devices.

Divider block device manufacturers have "simplified" things for the mechanic. Normally Open (NO) refers to the state the switch is in when the divider block is cycling or the unit is running. An NO switch means that when the unit is running the shutdown switch is open or non-failsafe. If a wire falls off or is cut while the unit is running the control system will never stop the unit. If the device is damaged or a wire has come loose at startup the control system would never know there is a problem. An NC switch means that when the unit is running the shutdown switch is closed or failsafe. Now if a wire falls off or is cut the control system will detect that the switch is open and shutdown the unit.

Ariel recommends using a NC (failsafe) switch. However, when a NO (non-failsafe) switch is used, Ariel recommends testing the shutdown circuits at least once a month.

**II. Proximity switch** - This is a device that will sense the position of the divider block piston and will produce a switch change of state or a pulse every time the pin changes position. This device must be combined with a PLC or some other counter/timer device to produce the shutdown. Some devices on the market will open the switch when the pin is toward the left and close when the pin is toward the right. Others will produce a 0.5 second pulse when the pin moves from left to right. If this is used it is the responsibility of the control system to sense the switch cycling and stop the unit if a block stops cycling.

#### **APPLICATION NOTES - Proximity Switch**

Ariel recommends setting up the control system to find the time between cycles triggered when the switch transitions from off to on. See Figure 4-7 suggested control system block diagram.

1. Shutdown time with no lubrication - The distribution block cycle times will vary slightly from cycle to cycle. Seeing 12 seconds one cycle then 15 seconds the next then 14 the next is normal. The recommended shutdown time is: 2 times the design cycle time + 30 seconds limited between 30 seconds and 3 minutes.

LIMIT (2 x design cycle time + 30 seconds) 30, 180

Design cycle time is found on the compressor lube sheets or tag on the compressor.

2. DE-BOUNCE and latching circuits - Depending on the device and control system scan time it may be necessary to include de-bounce hardware and/or software. Some of the devices do not have built in de-bounce circuits and can cause a fast control system to double or triple count. Other times it may be necessary latch the input thus allowing the control system to detect only the first transition from low to high. This becomes significant when displaying the cycle time for the operator to set the pump flow rates and when calculating the total oil through the divider block.
3. Suggested Operator Displays:

Divider block cycle time - The operator will need to set the lube system pumps according to the recommended divider block cycle times. It is helpful for the operator to have a display of divider block cycle time in seconds. This will be used to adjust the lube pumps as the pumps wear out and when the pumps are replaced to set divider block cycle times.

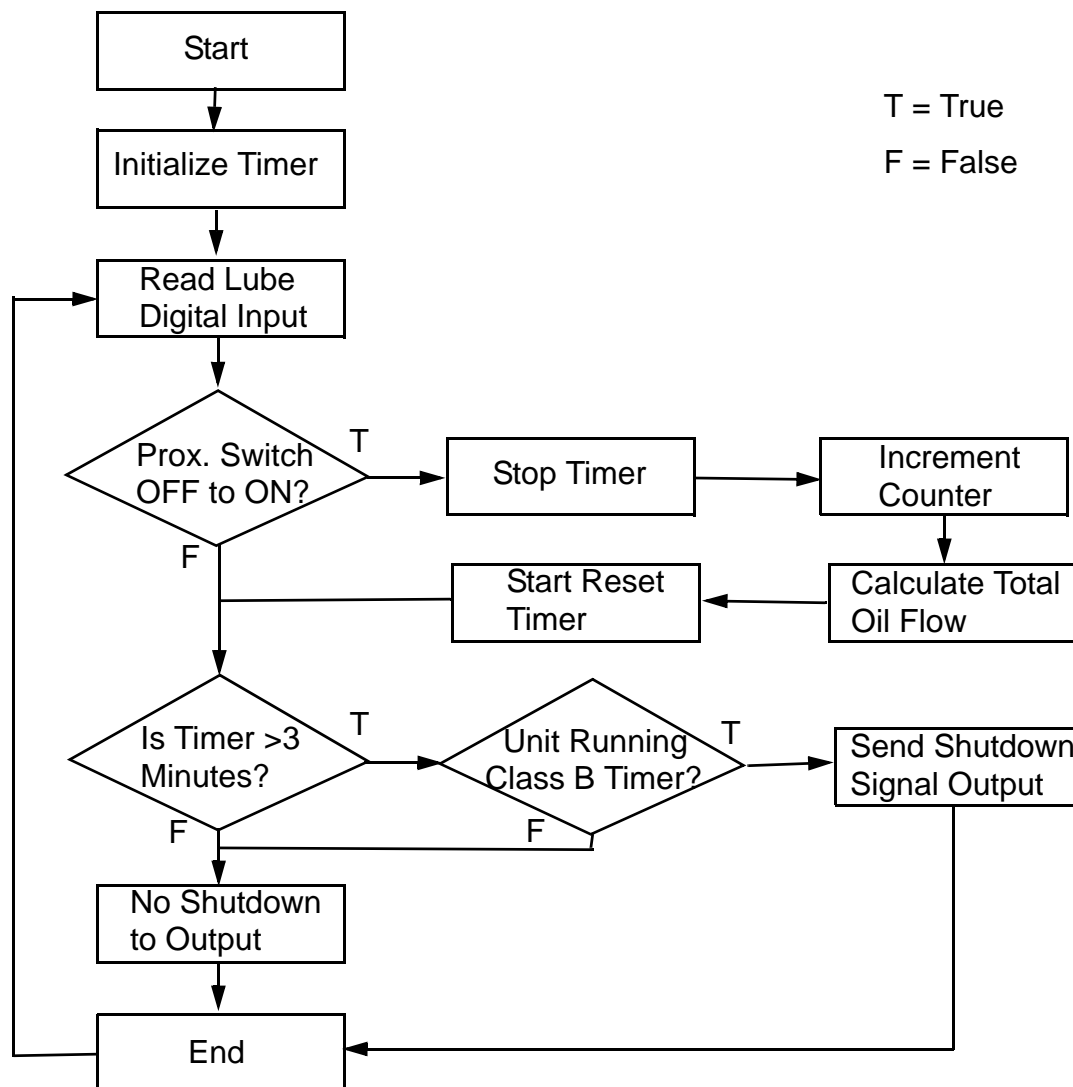
Time since last Pulse - It is helpful to have a display of the timer timing so the operator can see a change and show that something is happening.

Average Cycle Time - Cycle time will vary a few seconds from cycle to cycle. It is sometimes helpful to display a cycle time that has been averaged over 5 to 10 cycles.

Total Oil Consumed - Total oil consumed can be useful to the operator to know how much oil is being used for the lube system and thus how much oil to order.

**4. EXAMPLE FLOW DIAGRAM TO CREATE SHUTDOWN**

Figure 4-7 flow diagram is a suggested method of creating a shutdown within the PLC from a cycling digital input. This is only a suggestion as there is no way of providing logic for all control systems.



**FIGURE 4-7 SUGGESTED FORCE FEED LUBE CONTROL SYSTEM PROXIMITY SWITCH SHUTDOWN LOGIC DIAGRAM**

## Break-in Rate

The force feed lubrication pumps should be capable of delivering 150% minimum of the “normal” required lube rate for the break in period (set as close as possible to twice the “normal” rate for 200 hours). Please contact Ariel for assistance if the existing pump is not capable of the minimum flow rate required.

## Liquids in Gas

The use of higher viscosity lubricants or specially compounded lubricants can compensate somewhat for the presence of liquids in the gas stream.

**NOTE: WHEN THERE ARE LIQUIDS PRESENT IN THE GAS, THE MOST EFFECTIVE LUBRICATION OF CYLINDERS AND PACKING REQUIRES REMOVAL OF THE LIQUIDS BEFORE THE GAS ENTERS THE COMPRESSOR.**

**THESE LUBRICATION RECOMMENDATIONS ARE GENERAL GUIDELINES. IF THE RECOMMENDED LUBRICANTS OR FLOW RATES DO NOT APPEAR TO WORK ADEQUATELY, FLOW RATES AND/OR LUBRICANT TYPES MAY NEED TO BE CHANGED. PLEASE CONTACT THE LUBRICANT SUPPLIER FOR SPECIFIC LUBRICANT RECOMMENDATIONS.**

**WARRANTY OF COMPONENT FAILURES WHICH OCCUR WHILE USING LUBRICANTS WHICH DO NOT MEET THESE SPECIFICATIONS WILL BE SUBJECT TO REVIEW ON A CASE BY CASE BASIS.**

## Lube Type & Rate Recommendations

**TABLE 4-9 CYLINDER/PACKING LUBE OIL RECOMMENDATIONS FOR VARIOUS GAS STREAM COMPONENTS**

GAS STREAM	CYLINDER DISCHARGE PRESSURE				
	< 1000 PSIG < (70 bar <sub>g</sub> )	1000 TO 2000 PSIG (70 to 140 bar <sub>g</sub> )	2000 TO 3500 PSIG (140 TO 240 bar <sub>g</sub> ) <sup>A</sup>	3500 TO 5000 PSIG (240 to 345 bar <sub>g</sub> ) <sup>1</sup>	> 5000 PSIG > (345 bar <sub>g</sub> ) <sup>1</sup>
Pipeline Quality Natural Gas Including CNG (Dry)	SAE 40 wt. ISO 150 1 x Base Rate or Various Synthetics 1 x Base Rate	SAE 40-50 wt. ISO 150 - 220 1.25 x Base Rate or Various Synthetics 1 x Base Rate	SAE 50 wt. ISO 220 w/ Compounding 1.5 x Base Rate or Various Synthetics 1.25 x Base Rate	Cylinder Oil ISO 320 - 460 w/ Compounding 2 x Base Rate or Synthetic - Diester/Polyglycol 1.5 x Base Rate	Cylinder Oil ISO 460 - 680 w/ Compounding 3 x Base Rate or Synthetic - Polyglycol 2 x Base Rate
Natural Gas (Water Saturated, and/or Heavy Hydrocarbons <sup>b</sup> Methane < 90% Propane > 8% SG > 0.7)	SAE 40 - 50 wt. ISO 150 - 220 1.25 x Base Rate or Various Synthetics 1 x Base Rate	SAE 50 - 60 wt. ISO 220 - 320 or SAE 40 wt. ISO 150 w/ Compounding 1.5 x Base Rate or Var. Synthetics 1.25 x Base Rate	Cylinder Oil ISO 460 - 680 w/ Compounding 2 x Base Rate or Various Synthetics 1.5 x Base Rate	Cylinder Oil ISO 680 w/ Compounding 3 x Base Rate or Synthetic - Diester/Polyglycol 2 x Base Rate	Contact Lubricant Supplier
Natural Gas (Water Saturated and Carbon Dioxide > 2% to 10%)	SAE 40 - 50 wt. ISO 150 - 220 1.25 x Base Rate or Various Synthetics Base Rate	SAE 50 - 60 wt. ISO 220 - 320 or SAE 40 wt. ISO 150 w/ Compounding 1.5 x Base Rate or Var. Synthetics 1.25 x Base Rate	Cylinder Oil ISO 460-680 w/ Compounding 2 x Base Rate or Synthetic PAG 1.5 x Base Rate	Cylinder Oil ISO 680 w/ Compounding 3 x Base Rate or Synthetic PAG 2 x Base Rate	Contact Lubricant Supplier

**TABLE 4-9 CYLINDER/PACKING LUBE OIL RECOMMENDATIONS FOR VARIOUS GAS STREAM COMPONENTS**

GAS STREAM	CYLINDER DISCHARGE PRESSURE				
	< 1000 PSIG < (70 bar <sub>g</sub> )	1000 TO 2000 PSIG (70 to 140 bar <sub>g</sub> )	2000 TO 3500 PSIG (140 TO 240 bar <sub>g</sub> ) <sup>A</sup>	3500 TO 5000 PSIG (240 to 345 bar <sub>g</sub> ) <sup>1</sup>	> 5000 PSIG > (345 bar <sub>g</sub> ) <sup>1</sup>
Natural Gas (Water Saturated and Carbon Dioxide ≥ 10%)	SAE 40 - 50 wt. ISO 150 - 220 1.5 x Base Rate or Various Synthetics 1.25 Base Rate	SAE 50 - 60 wt. ISO 220 - 320 or SAE 40 weight ISO 150 w/ Compounding 2 x Base Rate or Var. Synthetics 1.5 x Base Rate	Cylinder Oil ISO 460-680 w/ Compounding 3 x Base Rate or Synthetic PAG 2 x Base Rate	Cylinder Oil ISO 680 w/ Compounding 4 x Base Rate or Synthetic PAG 3 x Base Rate	Contact Lubricant Supplier
Natural Gas (Water Saturated & H <sub>2</sub> S > 2% to 30%)	SAE 40 wt. ISO 150 w/ Compounding 1.25 x Base Rate or Various Synthetics 1 x Base Rate	SAE 40 - 50 wt. ISO 150 - 220 w/ Compounding 1.5 x Base Rate or Various Synthetics 1.25 x Base Rate	SAE 50 wt. ISO 220 w/ Compounding 2 x Base Rate or Various Synthetics 1.5 x Base Rate	SAE 60 wt. ISO 320 w/ Compounding 3 x Base Rate or Various Synthetics 2 x Base Rate	Cylinder Oil ISO 460 - 680 w/ Compounding 4 x Base Rate or Various Synthetics 3 x Base Rate
Natural Gas (Water Saturated & H <sub>2</sub> S ≥ 30%)	SAE 40 wt. ISO 150 w/ Compounding 1.5 x Base Rate or Various Synthetics 1.25 Base Rate	SAE 40 - 50 wt. ISO 150 - 220 w/ Compounding 2 x Base Rate or Various Synthetics 1.5 x Base Rate	SAE 50 wt. ISO 220 w/ Compounding 2.5 x Base Rate or Various Synthetics 2 x Base Rate	SAE 60 wt. ISO 320 w/ Compounding 3.5 x Base Rate or Various Synthetics 2.5 x Base Rate	Cylinder Oil ISO 460 - 680 w/ Compounding 5 x Base Rate or Various Synthetics 3 x Base Rate
Air or gas mixtures with greater than 4% oxygen content	Synthetic - Diester or Polyolester 1.5 x Base Rate Minimum ISO 100	Synthetic - Diester or Polyolester 2 x Base Rate Minimum ISO 150	Synthetic - Diester or Polyolester 3 x Base Rate Minimum ISO 150	Synthetic - Diester or Polyolester 3 x Base Rate Minimum ISO 150	Synthetic - Diester or Polyolester 3 x Base Rate Minimum ISO 150
	NOTE: For compressors w/1500 RPM Speed Rating & 1.5" (38 mm) or Greater Piston Rod Diameter, use:				
	3 x Base Rate	4 x Base Rate	4 x Base Rate	4 x Base Rate	4 x Base Rate
	NOTE: For compressors w/1800 RPM Speed Rating & 1.5" (38 mm) or Greater Piston Rod Diameter, use:				
4 x Base Rate	6 x Base Rate	6 x Base Rate	6 x Base Rate	6 x Base Rate	



**TABLE 4-9 CYLINDER/PACKING LUBE OIL RECOMMENDATIONS FOR VARIOUS GAS STREAM COMPONENTS**

GAS STREAM	CYLINDER DISCHARGE PRESSURE				
	< 1000 PSIG < (70 bar <sub>g</sub> )	1000 TO 2000 PSIG (70 to 140 bar <sub>g</sub> )	2000 TO 3500 PSIG (140 TO 240 bar <sub>g</sub> ) <sup>A</sup>	3500 TO 5000 PSIG (240 to 345 bar <sub>g</sub> ) <sup>1</sup>	> 5000 PSIG > (345 bar <sub>g</sub> ) <sup>1</sup>
Nitrogen	SAE 40 wt. ISO 150 1 x Base Rate or Various Synthetics 1 x Base Rate	SAE 40 - 50 wt. ISO 150 - 220 1 x Base Rate or Various Synthetics 1 x Base Rate	SAE 50 wt. ISO 220 1 x Base Rate or Various Synthetics 1 x Base Rate	SAE 60 wt. ISO 320 1 x Base Rate or Various Synthetics 1 x Base Rate	Cylinder Oil ISO 460 - 680 1 x Base Rate or Various Synthetics 1 x Base Rate
Propane <sup>c</sup> (Refrigerant)	SAE 40 wt. ISO 150 or Refrigerant Oil 0.5 x Base Rate or Various Synthetics 0.5 x Base Rate	SAE 40 wt. ISO 150 or Refrigerant Oil 1 x Base Rate or Various Synthetics 1 x Base Rate	Refrigerant Oil Contact Lubricant Supplier	Refrigerant Oil Contact Lubricant Supplier	Refrigerant Oil Contact Lubricant Supplier

- a. Also requires water-cooled packing (except cylinders on JG, JGA, JGM, JGN, JGP, JGQ & JGI).
- b. Lean burn engine oils contain detergents, dispersants and ash additives, which hold water in suspension. This suspension does not provide adequate lubrication in the cylinder and packings.
- c. Verify oil pour point temperature is below inlet gas temperature.
- 4. Reference Table 4-10 for base rate.

**TABLE 4-10 CYLINDER/PACKING LUBE OIL BASE RATE**

FRAME MODEL	US PINTS/DAY/INCH OF BORE DIAMETER	LITERS/DAY/mm OF BORE DIAMETER
JG:A:I:M:P:N:Q:R:S:W	0.3	0.0056
JGH:E:J:ACF	0.4	0.0074
JGK:T:C:D:Z:U:B:V:KBB:V	0.5	0.0093

### RATE CALCULATION NOTES

**Packing Lube Rate** - Piston rod diameter is doubled and treated like a cylinder for calculating packing lube rate. For cylinders with a tail rod, the lube rate for each of the (two) packings is to be calculated separately and both values added toward the recommended total daily lube rate.

**Lube Points** - Cylinders for JG:A:I:M:P:N:Q:R:W:H:E:J and ACF frames with bore diameters less than 13" (<330 mm) have one point bore lube as standard; top and bottom bore lube is available as an original purchase option, (except for all Class T cylinders and 1-3/4JG-FS-HE class cylinders, which have multi-point lube as standard). For all other frames, the cylinders have multiple bore lube points as standard. Piston rod packings for high-pressure cylinders have two point lube. For multiple lube points, the required lubricant for the cylinder or packing is divided equally among the lube points.

**Break-in Lube Rate** - The break-in lube rate should be approximately twice the recommended daily rate (150% minimum); i.e. the break-in cycle time should be approximately half the normal cycle time (67% max.) to increase lube rate. Break-in rate should be maintained for 200 hours of operation for new equipment, or when replacing packing and/or piston rings.

**Lube Rate and Speed** - The recommended lube rates for break-in or normal operation, in cycles per second (as stamped on the lubricator box information plate and in Lube sheets), are calculated at maximum rated compressor speed (as stamped on the compressor information plate). The lube rate is reduced with speed, (as compressor actual running speed is reduced, cycle time increases to reduce lube rate):

$(RPM_{max} \div RPM_{actual}) \times \text{cycle time seconds from lube plate} = \text{cycle time seconds, at actual running speed.}$

Or reference the "Lubrication sheets" in the Ariel "Parts Book" for the Cycle Time (seconds) vs. RPM (compressor speed) Table at various running speeds for your compressor, at the stated gas operating conditions and lubricant.

**Special Lubricant Certification** - Special lubricant formulations are available from lubricant suppliers for specific applications. Suppliers who will certify suitability of the formulation for site conditions should provide appropriate documentation. Contact Ariel for verification of warranty coverage.

**Calculation Example**, recommended daily lube rate:

JGJ/2, with Pipeline Quality Natural Gas, and following cylinder bore diameters (actual bore diameter as shown on cylinder data plate), and 1.5 inches (38.1 mm) diameter piston rod, with mineral oil type lubricant:

13.00"J (330 mm) at 100 psi discharge pressure (6.89 bar). Table 4-9 factor = 1.

9.75"J-CE (248 mm) at 577 psi discharge pressure (39.8 bar), Crank End. Factor = 1.

5.125"J-HE (130 mm) at 1636 psi discharge pressure (112.8 bar), Head End. Factor = 1.25.

**TABLE 4-11 EXAMPLE CYLINDER & PACKING LUBE CALCULATION**

US pints per day; ppd		
Cylinder Bore	Packing	Sub
1 x 13.00 in. x 0.4 ppd/in. = 5.2	2 x 1.5 in. x 0.4 ppd/in. = 1.2	6.4
1 x 9.75 in. x 0.4 ppd/in. = 3.9	2 x 1.5 in. x 0.4 ppd/in. = 1.2	5.1
1.25 x 5.125 in. x 0.4 ppd/in. = 2.6	N/A	2.6
Recommended Total, ppd =		14.1
(Liters per day; L/day)		
Cylinder Bore	Packing	Sub
1 x 330 mm x 0.0074 L/day/mm = 2.4	2 x 38.1 mm x 0.0074 L/day/mm = 0.56	(3.0)
1 x 248 mm x 0.0074 L/day/mm = 1.8	2 x 38.1 mm x 0.0074 L/day/mm = 0.56	(2.4)

TABLE 4-11 EXAMPLE CYLINDER & PACKING LUBE CALCULATION

US pints per day; ppd		
1.25 x 130 mm x 0.0074 L/day/mm = 1.2	N/A	(1.2)
Recommended Total, (L/day) =		(6.6)

## Water-Cooled Packing

Water-cooled packing cases are required for compressor cylinders based upon the average piston speed and average cylinder pressure. Cooled packing cases are supplied to help remove heat generated as the piston rod/packing friction increases with the higher pressures and piston speed.

Cooled packing cases are required for cylinders in accordance with Figure 4-8.

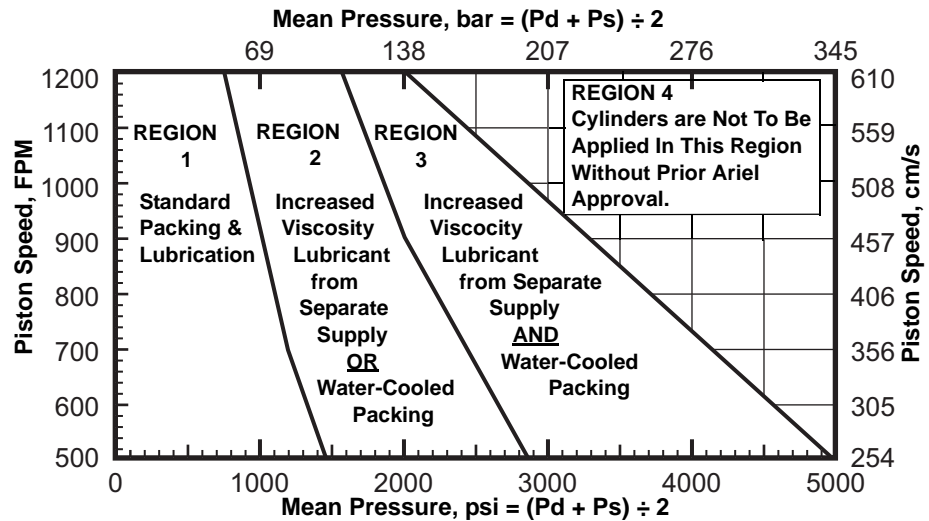


FIGURE 4-8 COMPRESSOR PACKING APPLICATION GUIDELINES FOR PIPELINE QUALITY NATURAL GAS

1. All cylinders that have water-cooled packing as standard (see Ariel Performance Program) must be connected to a water cooling system, unless prior approval is obtained from Ariel Technical Services.

2. If a separate lube supply is needed due to the gas analysis (H<sub>2</sub>S, CO<sub>2</sub>, water saturation, air, etc.) an additional increase in viscosity may be needed if the cooling connection to a water cooled packing case is omitted. Contact Ariel Technical Services for assistance.

3. Cooling water quality and treatment is to be maintained to prevent corrosion and mineral or other deposits. Cooling water must be treated with an appropriate anti-freeze, such as glycol, if subject to freezing.

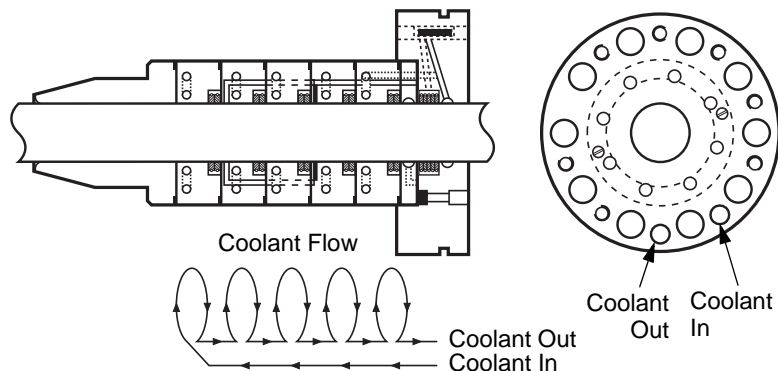


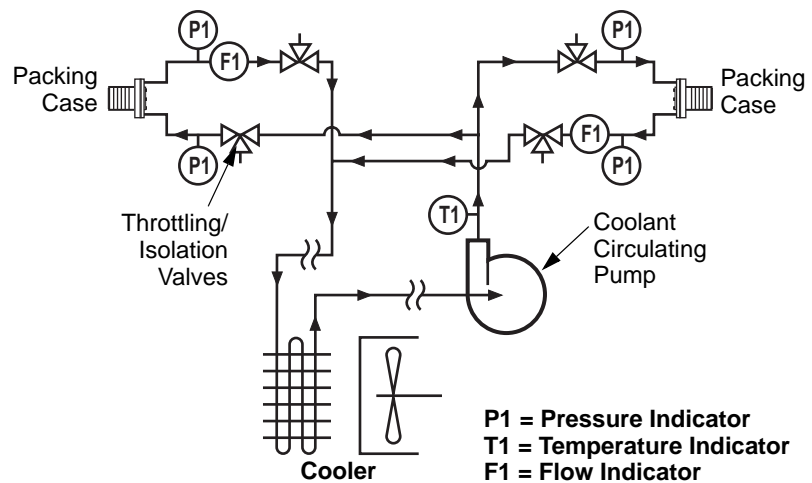
FIGURE 4-9 WATER-COOLED PACKING CASE - TYPICAL

## Coolant System Requirements

The coolant flow is to be number of packing cases x 1 US gallon per minute, minimum for each inch of piston rod diameter (No. cases x 0.149 L/min for each mm of piston rod diameter). Based on using a treated 50/50% water/glycol solution.

Example: JGJ/2 with 1.5 inches (38.1 mm) diameter piston rod.  $2 \times 1 \times 1.5 = 3$  gallons per minute ( $2 \times 0.149 \times 38.1 = 11.3$  L per minute).

The cooler should be sized for number of cases x 70 BTU/minute/inch of rod diameter (No. cases x 0.05 kW/mm of rod diameter). The pressure drop across the system is to be greater than 30 psi (2.1 bar). The coolant into the packing is not to exceed 130°F maximum (54°C max.). A lower coolant temperature will increase the amount of heat that can be transferred to the coolant. A lower coolant temperature is better in high pressure applications.



**FIGURE 4-10 PACKING COOLING SYSTEM - TYPICAL**

## Force Feed Lubrication System - Description

The force feed lubrication system provides oil to the compressor cylinders and the piston rod packings.

Oil is supplied to the 150 micron sintered bronze filter on the suction side of the force feed lubricator pump directly from the pressure side of the frame lube oil system, or from an overhead tank. Oil from the filter is supplied to a header and to the lubricator pumps on the lubricator box.

The lubricator box has its own oil reservoir to lubricate the worm gear and cam. The reservoir is self-contained and is not fed by the lube oil system. A sight glass on the lubricator box will show the oil level in the lubricator reservoir.

There are 1/4 inch tube fitting connections in the discharge lines near the force feed lubricator pumps through which the force feed lubrication system may be primed.

Next in the discharge lines are blow-out fittings with rupture disks. If there is a blockage in the system, the pressure build-up will rupture the disks. Venting the system through the rupture disk causes the no-flow shutdown switch to close.

The oil then travels to the distribution blocks. It is here that the lubricating oil is apportioned to provide the exact amounts to the cylinders and packings. The pistons in the intermediate sections of the distribution block move back and forth in a continuous cycle, forcing lubricant successively through the several outlets as long as lubricant is supplied under pressure at the inlet. Each outlet has a check valve to prevent oil from backing up in the block. An indicator

on the block shows the rate at which the block is cycling.

From the distribution blocks, oil travels to the cylinders and packings. The system provides 1 inch min. (25 mm) of head at the guide and cylinder inlets to help ensure long check valve life.

Some of the oil to the packing travels through to the cylinders, but the bulk of it is drained out through the pressure vent/drain fitting on the bottom of the crosshead guide and through the atmospheric drain also in the bottom of the guide.

An oil level control valve, supplied by the packager and mounted on the skid, maintains proper level in the crankcase sump to replace oil used in cylinder lubrication.

### Force Feed Lubricator Adjustment

See instructions under “Force Feed Lubricator Adjustment” in Technical Manual Section 3.

**NOTE: THE FORCE FEED SYSTEM MUST HAVE A BLOW-OUT FITTING WITH A PROPERLY RATED RUPTURE DISK, INSTALLED IN THE TUBING LINE BETWEEN THE FORCE FEED LUBRICATOR PUMP AND THE NO-FLOW SHUTDOWN. THE DISK COLOR SHOULD SHOW AT THE FITTING BLOW-OUT HOLE. THE FORCE FEED SYSTEM MUST HAVE A WORKING NO-FLOW SHUTDOWN SET TO ACTUATE WITHIN THREE TO FIVE MINUTES AFTER INTERRUPTION OF THE LUBRICATOR OIL FLOW.**

**CAUTION!: USE A MIRROR TO VISUALLY INSPECT FOR PROPER RUPTURE DISK COLOR, IF THE FORCE FEED SYSTEM IS PRESSURIZED. A RUPTURING DISK OR HIGH PRESSURE OIL CAN POTENTIALLY CAUSE PERSONAL INJURY.**

### Blow-Out Fittings, Rupture Disks and Tubing

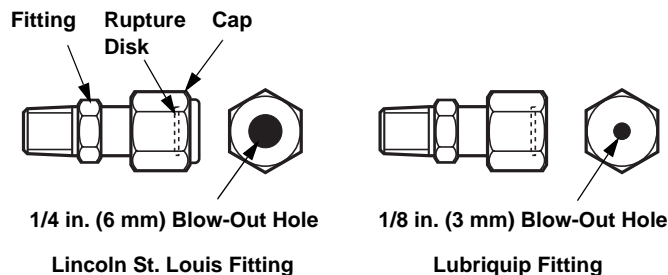


FIGURE 4-11 BLOW-OUT FITTING ASSEMBLY

TABLE 4-12 BLOW-OUT FITTINGS, REPLACEMENT RUPTURE DISKS & TUBING

BLOW-OUT FITTING <sup>A</sup>		REPLACEMENT RUPTURE DISK <sup>B</sup>			STANDARD TUBING - 304 SS <sup>C</sup>		
TYPE	ARIEL P/N	RATING psig (bar <sub>g</sub> )	ARIEL P/N	COLOR	SIZE in. (mm)	RATING psig (bar <sub>g</sub> )	ARIEL P/N
Lincoln	A-0080	3250 (224)	A-0124	Purple	1/4 x 0.035 wall (6.4 x 0.9)	5100 (352)	PT0200CB
Lubriquip	A-3531	3700 (255)	A-3536	Yellow			
Lubriquip	A-3532	4600 (317)	A-3537	Red			

TABLE 4-12 BLOW-OUT FITTINGS, REPLACEMENT RUPTURE DISKS &amp; TUBING

BLOW-OUT FITTING <sup>A</sup>		REPLACEMENT RUPTURE DISK <sup>B</sup>			STANDARD TUBING - 304 SS <sup>C</sup>		
TYPE	ARIEL P/N	RATING psig (bar <sub>g</sub> )	ARIEL P/N	COLOR	SIZE in. (mm)	RATING psig (bar <sub>g</sub> )	ARIEL P/N
Lubriquip	A-3533	5500 (379)	A-3538	Orange	1/4 x 0.065 wall (6.4 x 1.7)	10,200 (703)	PT0201CD
Lubriquip	A-3534	6400 (441)	A-3539	Pink <sup>d</sup>			
Lubriquip	A-3535	7300 (503)	A-3540	Blue			

- a. Be sure to apply the proper rupture disk to match your blow-out fitting type, see Figure 4-11, and application pressure. Generally the rupture disk should be rated about 1000 psig (70 bar<sub>g</sub>) greater than the highest MAWP cylinder.
- b. See Technical Manual Section 1, Fastener Tightening Values Table or the toolbox torque tables (ER-63) for blow-out fitting cap tightening torque. Do not over tighten cap or rupture pressure can be reduced.
- c. All tubing down stream from a force feed pump for a pump circuit rated 5500 psig (380 bar<sub>g</sub>) or greater (orange, pink and blue disks), that is circuits with any cylinders greater than 3600 psig MAWP (248 bar<sub>g</sub>), should be 1/4 inch x 0.065 (6.4 x 1.7 mm) heavy wall stainless steel high pressure tubing. Rated tubing pressures are calculated from equations in ASME/ANSI B31.3 code for pressure piping, based on maximum outside diameter and minimum wall thickness. When grade 316 stainless steel tubing is specified on new compressor sales orders, 1/4 inch x 0.065 (6.4 x 1.7 mm) tubing is provided, regardless of rupture disk or cylinder ratings.
- d. Color code changed to pink (3/20/05) was uncoated aluminum.

## Divider Valves

**NOTE: REFER TO PARTS BOOK FOR THE FRAME BEING SERVICED FOR ASSEMBLY DRAWINGS, PARTS LIST AND REPAIR KITS THAT ARE AVAILABLE FOR DIVIDER VALVES.**

### Description

Divider valves are comprised of three to eight valve blocks fastened to a segmented baseplate. O-rings are used to seal between the valve blocks and the base plate and between the base plate segments. These divider valves are used in a single line, progressive lubrication system and can be used for dispensing oil or grease. Valves and base plate segments are supplied with Viton O-rings (90 Durometer).

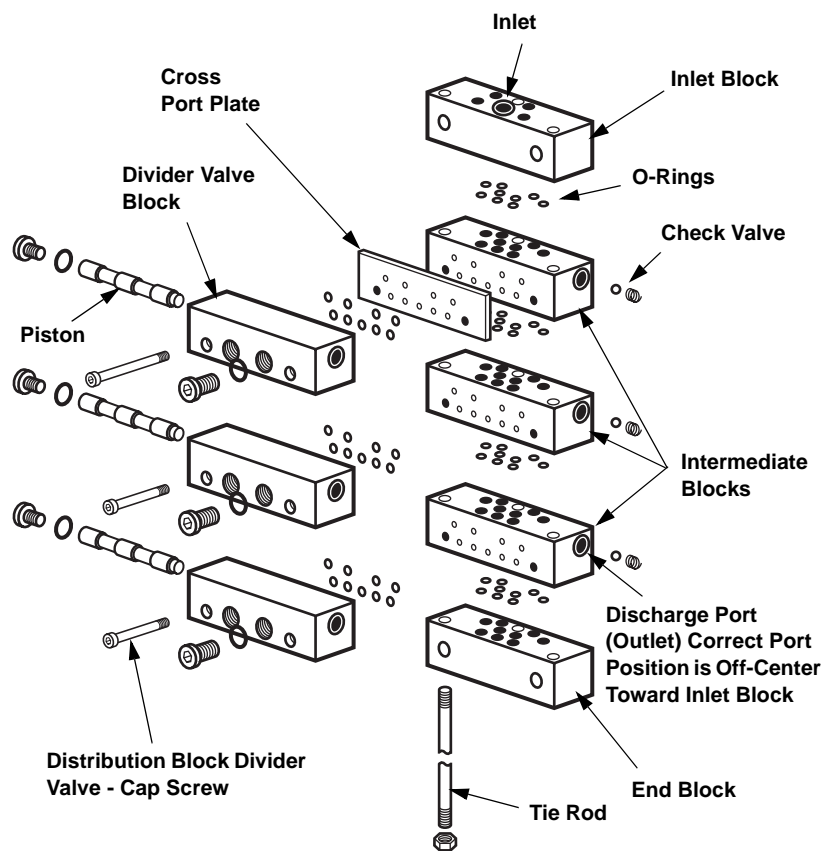
Check valves are installed at the outlets of all lube ports.

Valve blocks containing metering pistons discharge a predetermined amount of lubricant with each cycle. Valve blocks can be single or twin and can be externally singled or cross-ported. Outlets not to be used when singling or cross-ported must be plugged.

A by-pass block can be used in any position on the base plate. The use of a by-pass block allows the addition or deletion of lubrication points without disturbing existing tubing. Both outlets under a by-pass block must be plugged.

The valve blocks and by-pass blocks are fastened to a base plate mounted on the machine to be lubricated. The base plate contains the divider valve's inlet and outlet connections, interrelated passageways and built-in check valves. All piping of lubricant to and from the divider valve is connected to the base plate.

The base plate consists of one inlet block, three to eight intermediate blocks, one end block and three tie rods. O-ring seals are included with the base plate segments. The valve block capacity of each base plate is dependent upon the number of intermediate blocks in the base plate. There must be a minimum of three working valves on each valve and base plate assembly.



**FIGURE 4-12 DIVIDER VALVES DISTRIBUTION BLOCK - TYPICAL**

## Divider Valve Block Assembly Instructions

1. Screw three tie rods into inlet block until ends are flush with surface of block. Reference Figure 4-12 on page 4-34.
2. Slide intermediate blocks onto tie rods being sure that all O-rings are installed, and the discharge ports are off center toward the inlet block.
3. Slide end block onto tie rods.
4. Lay base plate assembly on flat surface and tighten nuts to the torque value given in Section 1.
5. Mount divider valves with O-rings onto base plate and tightening mounting cap screws to the torque value given in Section 1, in alternating steps.

### Operation - (see Figure 4-13 and Figure 4-14)

The inlet passageway is connected to all piston bores at all times with only one piston free to move at any one time. All outlets are provided with check valves.

As section 3 piston moves to the right, to position all pistons at the far right, lubricant flows to Outlet 6, see illustration 1. In this position, high pressure lubricant from the inlet through interconnecting passages flows against the right end of the section 1 piston.

Lubricant flow shifts section 1 piston from right to left dispensing lubricant to Outlet 1 (see illustrations 2 & 3). Section 1 piston shift directs lubricant flow against the right side of section 2 piston (see illustration 3).

Lubricant flow shifts section 2 piston from right to left dispensing lubricant to Outlet 2 (see illustrations 4 & 5). Section 2 piston shift directs lubricant flow against the right side of section 3 piston (see illustration 5)

Lubricant flow shifts section 3 piston from right to left dispensing lube to Outlet 3 (see illustrations 6 & 7). Section 3 piston shift directs lubricant flow against the left side of section 1 piston (see illustration 7).

Lubricant flow against left side of section 1 piston begins the second half-cycle which shifts pistons from left to right dispensing lubricant through Outlets 4, 5 and 6 of the divider valve (see illustrations 8 through 12 and illustration 1).

If pistons refuse to move, bleed off pressure on divider block and check for air lock in one or more valve ports by manually shifting a piston from right to left. Remove end plug and push piston with a clean soft rod that will not damage the bore.



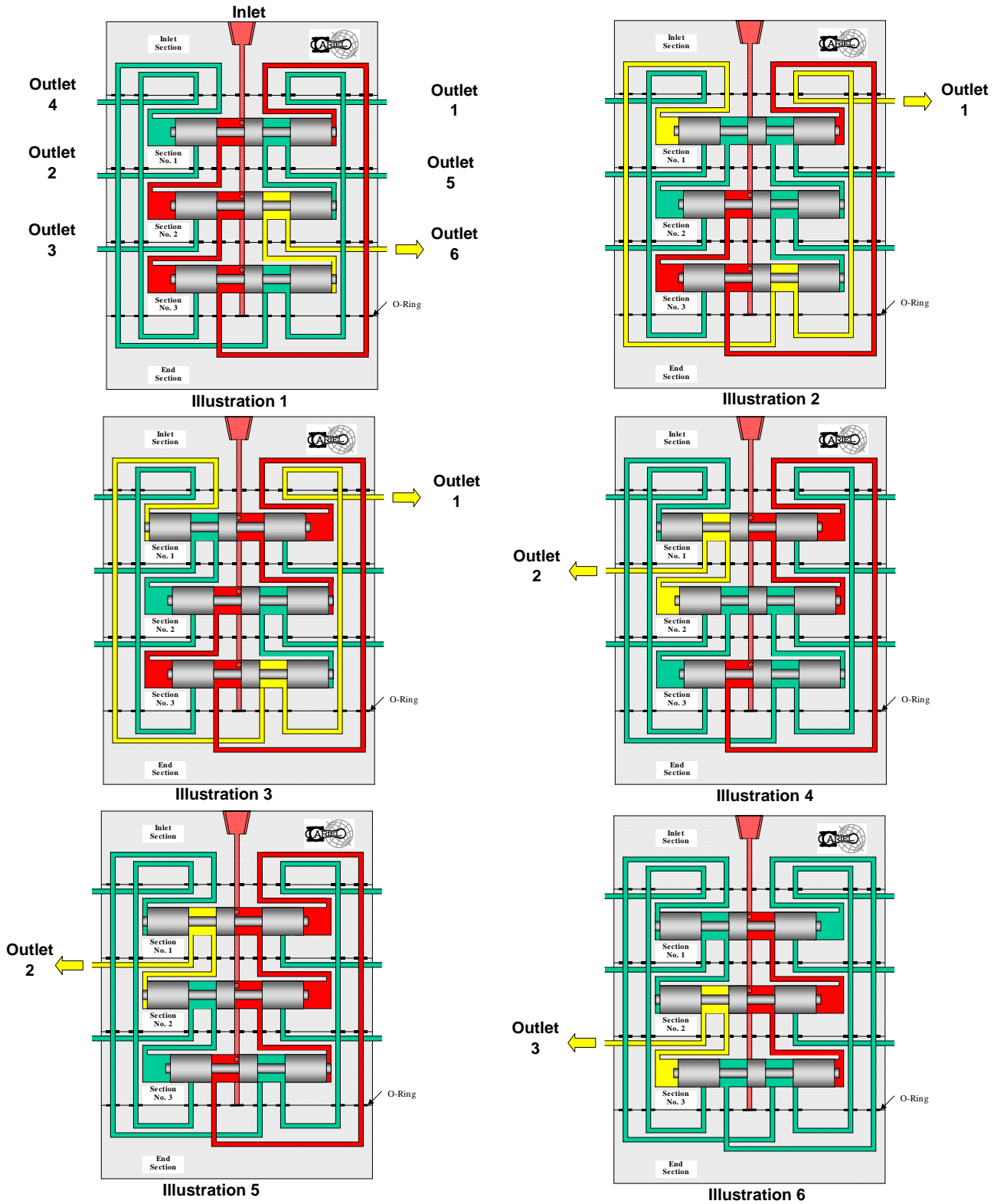


FIGURE 4-13 DIVIDER VALVE OPERATION SCHEMATIC - 1 THROUGH 6

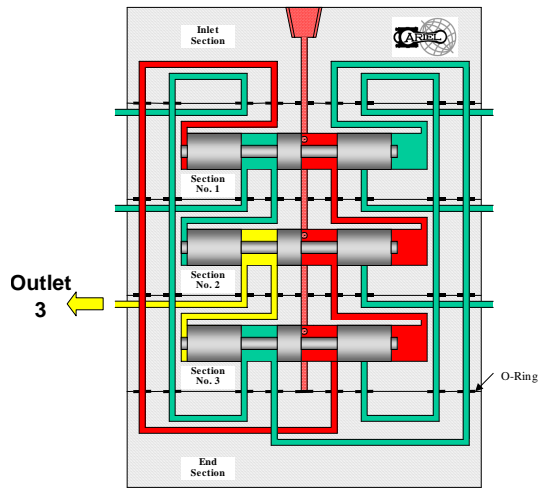


Illustration 7

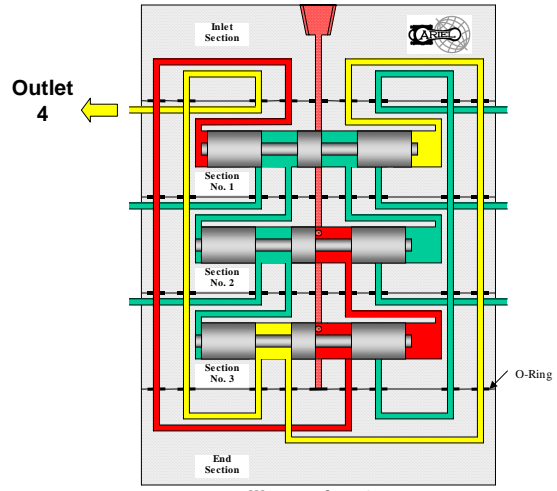


Illustration 8

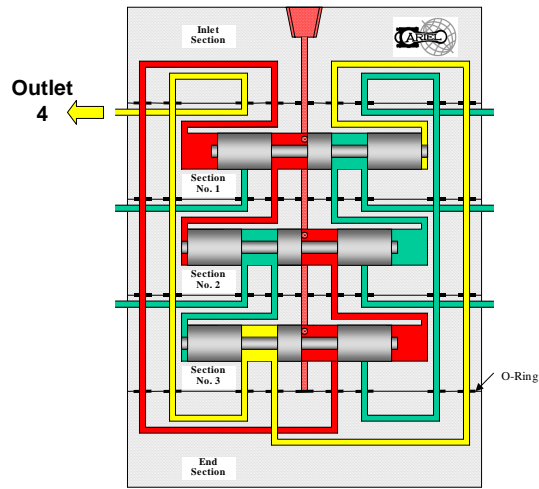


Illustration 9

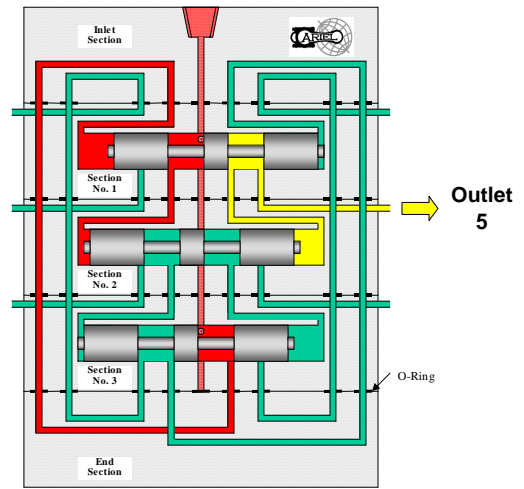


Illustration 10

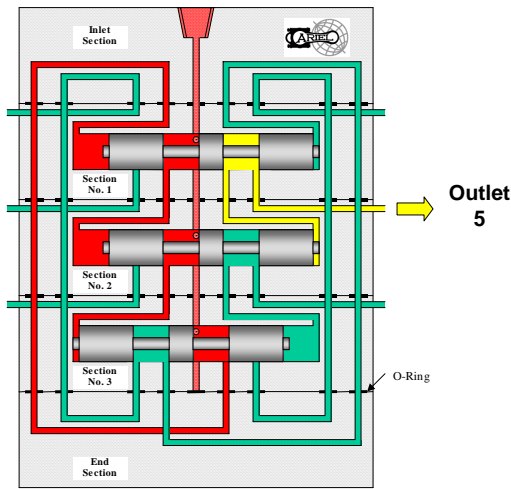


Illustration 11

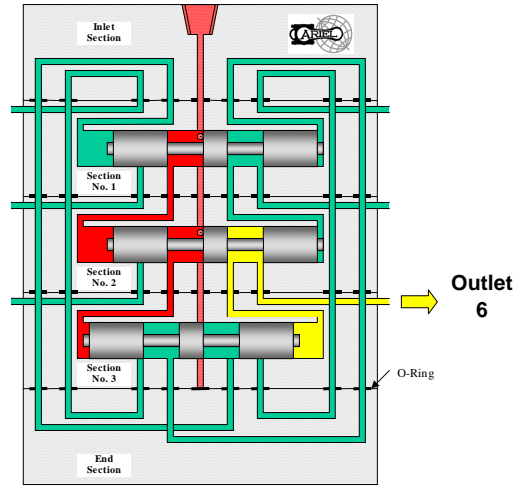


Illustration 12

FIGURE 4-14 DIVIDER VALVE OPERATION SCHEMATIC - 7 THROUGH 12

## Pressure Testing For Divider Valve By-Passing

Divider valve piston to bore are metal to metal sealing surfaces. Lubricant by-passing can result from excessive clearance between the piston and bore due to wear. Pressure test all divider blocks that are in service yearly, and replace any divider valves that fail to pass. Testing helps to ensure the piston to bore clearances are close enough to build adequate pressure to force oil into the injection point. All new Ariel divider valves are provided pressure tested by the supplier.

To test divider blocks for valve by-passing, a manual purge pump equipped with a pressure gauge, and capable of developing 5000 psig (350 bar<sub>g</sub>) is necessary. Such a force feed lubrication system purge gun (hand pump kit) with a pressure gauge is available from Ariel as an optional purchase tool. For pressure testing the divider block use a 10-weight oil at room temperature to simulate a hot lubricant. Test each divider block assembly complete with pin indicators installed. Test only one divider valve at a time.

Place the divider block assembly in an open container with all base outlets open. Connect the purge pump to the inlet of the divider block assembly. Operate the purge pump to cycle the divider block several times to purge air from the assembly and verify that oil will flow freely from all outlets. Divider blocks should cycle at less than 300 psig (21 bar<sub>g</sub>). See Figure 4-15 "Divider Block All Outlets Open".

Divider valves stamped with a "T" are to have only one outlet on the base plugged during testing of that side of the piston. Each base outlet of the divider valves stamped with a "T" must be plugged and tested one side at a time. See Figure 4-15 "Testing "T" Divider Valve". Individual testing of each outlet ensures both sides of the piston will build adequate pressure. All divider valves stamped with an "S" on the front are to have both outlets on the base plugged to test for by-passing. See Figure 4-15 "Testing "S" Divider Valve". This will test both sides of the piston at the same time.

Plug the outlet on the base behind the divider valve being tested with a 1/8 inch pipe plug. If a tubing fitting is installed in the base, plug the fitting with a tubing plug. Leave all other outlets open. Operate the purge gun until the pressure gauge indicates 3000 psig (207 bar<sub>g</sub>). The block may cycle once or twice, but should pressurize to 3500 psig (241 bar<sub>g</sub>) immediately. Stop pumping oil into the divider block at 3500 psig (241 bar<sub>g</sub>). Check the plug(s) in the discharge outlet(s) to confirm there are no external leaks. If the pressure gauge on the purge gun drops suddenly and oil squirts from the other outlets, a by-pass condition exists. The piston is worn and is allowing oil to by-pass. The pressure gauge should not lose more than 1000 psig (69 bar<sub>g</sub>) during a 30-second test period. Note: Testing the divider blocks at higher pressures is necessary if the application dictates a higher system operating pressure.

If a divider valve does not pass, it must be replaced. Discard worn divider valves. If the tested valve does not lose more than 1000 psig (69 bar<sub>g</sub>) in 30 seconds, relieve the pressure, move the plug to the next outlet and repeat the test for all divider valves. When divider valves have passed pressure testing to this procedure or have been replaced, a divider block may be reassembled, purged with the proper force feed lubricant being used and put into service.

By the nature of this divider block pressure testing procedure, in a static position through the divider valves above, it is not infallible. Periodic testing for proper lubrication rates in the cylinder bore and/or aftermarket devices that measure flow are recommended.

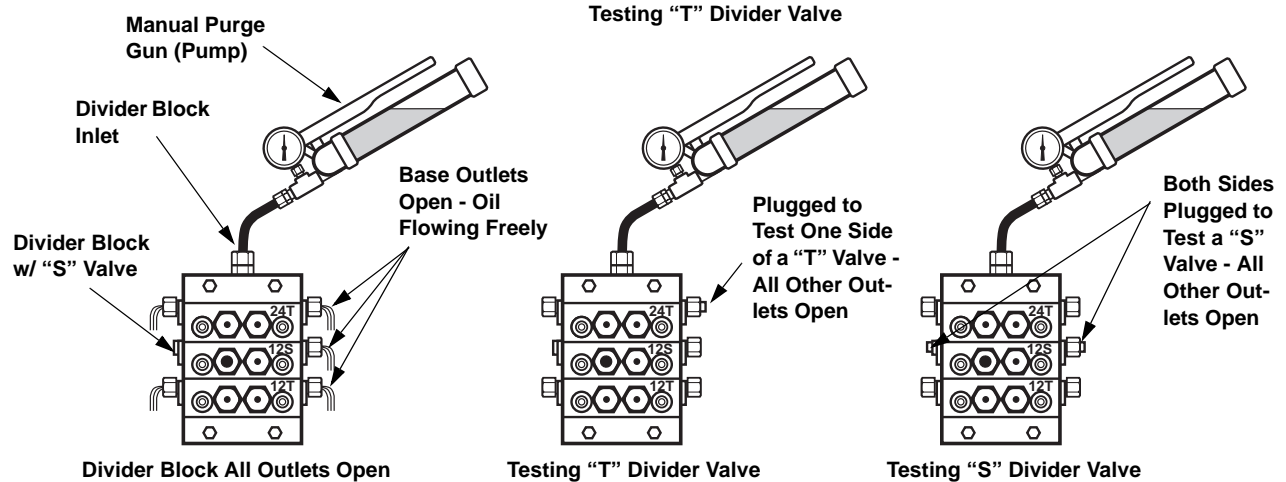


FIGURE 4-15 PRESSURE TESTING DIVIDER BLOCKS

## Electronic Lubricator Fluid-Flow Monitor/No-Flow Timer Switch - Proflo PF1

The **Proflo PF1** is a battery powered programmable electronic microprocessor-based switch used to sense slow-flow or no-flow conditions in the compressor cylinder force feed lubrication system to facilitate alarm and/or shutdown. It also has many features that can help ease the operation of the force feed lube system by allowing accurate monitoring of the cycle time and system performance. This information may be used to optimize force feed lube and reduce operating costs. The Proflo PF1 fluid-flow monitor is shown in the Figure.

If a DNFT (electronic-lubricator digital no-flow timer switch) is supplied in lieu of a Proflo, see “Electronic-Lubricator Digital No-Flow Timer Switch (DNFT)” on page 4-49.

The Proflo PF1 monitor works through a magnetic pin that cycles back and forth as the divider valve piston moves. The magnetic pin housing is normally screwed into the divider valve block, the monitor box housing slides on to the pin housing and is held in place by two (2) hexagon-socket set screws.

The front face of the monitor box housing has a liquid crystal display (LCD) window to provide

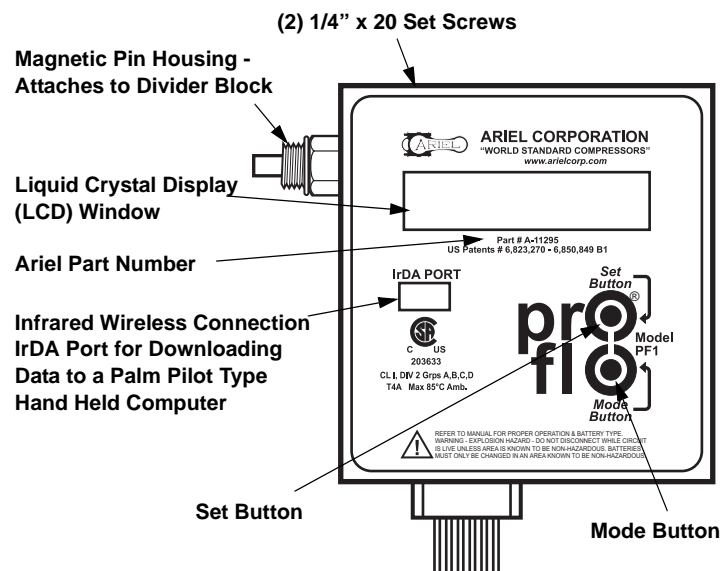


FIGURE 4-16 ELECTRONIC LUBRICATOR FLUID-FLOW MONITOR & NO-FLOW TIMER SWITCH - PROFLO PF1

a visual indication of the following:

1. Total operating time of the force feed lube system in hours.
2. "Average", "Last" and "Current" cycle time of the divider block in seconds.
3. Total divider block cycles.
4. Remaining battery power life in percent.
5. Alarm set time for no-flow indication (programmable 30 to 240 seconds).
6. Alarm wiring mode: Normally Open or Normally Closed.

## **Proflo PF1 Monitor wiring identification and instructions for electronic indication:**

**NOTE: IF THE PULSE OUTPUT (BLUE WIRES) AND ALARM CIRCUIT (RED WIRES) ARE TO BE USED AT THE SAME TIME, PLEASE REFER TO “Proflo PF1 - Using Pulse Output and Alarm Circuit at Same Time:” on page 4-47.**

### **Blue Wires:**

**Pulse output.** The two (2) blue wires can be used to send a transistor pulse output for each divider block cycle to a PLC (Programmable Logic Controller), Scada System, Digital Counter or Digital Control Panel. Maximum switching load is 36 Vdc @ 500mA. **Insulate blue wire ends from each other and conduit or compressor ground when not in use.** Pulse duration is 500 milliseconds. Switch output operation: Pulse represents 1 divider block cycle or period.

### **White Wires:**

**Switch input. Remote mounting Proflo PF1 display.** The two (2) white wires can be connected to a dry contact proximity switch. This allows remote mounting of the monitor box housing in a convenient location on the compressor frame or in the control panel. Ariel recommends distance between proximity switch and the panel mounted Proflo should not exceed 600 feet (183 m). Please refer to Proflo PF1 operating notes for more information. **Insulate white wire ends, from each other and from ground, when not in use.** For panel mount kit, see “Proflo PF1 Accessories Available:” on page 4-49.

### **Red Wires:**

**Alarm switch output.** The two (2) red wires are for a no-flow alarm contact. This can be used for alarm or shutdown no-flow indication at a control panel. When the divider block cycles this contact closes when in Normally Closed (NC) operation and opens when in Normally Open (NO) operation. The contact returns to static state when the preset timer times out. Switching Capacity: 36 Vdc @ 500 mA max. **Insulate red wire ends from each other and from ground when not in use.** This output operation is programmable as NO or NC. Ariel recommends using a NC system for fail-safe operation. Red wires are not polarity sensitive. See “Proflo Normally Open and Normally Closed Definition:” on page 4-46.

### **Green Wire:**

The green wire must be securely grounded to an "earth ground" on the compressor frame or in the control panel. Do not ground to the electrical conduit. Improper grounding can result in unreliable operation of the monitor.

**NOTE: TO SWITCH TO 120/240 VAC LOAD USING THE PROFLO PF1 OUTPUTS, A RELAY INTERFACE MUST BE USED. SEE “Proflo PF1 Accessories Available:” ON PAGE 4-49.**

## Proflo PF1 Button Operation:

Following is a description of how an operator can use the Proflo PF1 buttons.

1. First push set button on the front of the monitor box housing to clear ALARM and the **LCD** will display **LAST** and **AVG**. When this is done the alarm output contact will go to the as running state. If the operation is set to **NC** then the output alarm contact will close.

**LAST** is the last divider block cycle time in seconds.

**AVG** is the average time of the last six (6) divider block cycles in seconds.

2. Push the mode button once and the **LCD** will display **NOW**.

**NOW** is the current divider block cycle time in seconds.

This mode allows the operator to accurately change the cycle time by adjusting the force feed lubricator pump. Break-in and normal lube timing in seconds per cycle is given on the force feed lubricator data plate on the lubricator box at maximum rated speed, based on the gas operating conditions provided to Ariel (or clean, dry 0.65 S.G. sweet natural gas, rated speed and discharge pressures if no conditions were provided), when plate was installed. At reduced compressor speeds cycle time may be increased in a directly proportional relationship. At 50% rated speed the lube cycle time is doubled (see lube sheets provided in the Ariel Parts Manual for table of speeds vs. cycle timing).

3. Push the mode button again and the **LCD** will display **RUN TIME**.

**RUN TIME** is the total run time of the lube system in hours since the last reset.

4. Push the mode button a third time and the **LCD** will display **CYCLE TOTAL**.

**CYCLE TOTAL** is the total divider block cycles since the last reset.

5. Push the mode button a fourth time and the **LCD** will display **BATTERY - PCNT**. If battery voltage drops below safe operating levels the monitor will go into **ALARM** mode.

**BATTERY - PCNT** indicates percent of remaining battery life.

The display mode will change to alarm when the Proflo PF1 goes into alarm. The display will default to LAST and AVG display when the divider block is cycling.

## Downloading Proflo PF1 Data:

A hand held Palm operating system computer equipped with an infrared (IrDA) port and running Palm Operating System can be used to interface with the Proflo PF1. CCT Incorporated, Fluid Flow Trending (FFT) software can be used to download operating data. Using this feature is not essential for compressor operation, but recommended for evaluating the force feed lube operation and reducing operating costs. See “Proflo PF1 Accessories Available:” on page 4-49, for more info on the FFT software. The following information may be obtained:

1. Oil consumption for each 30-minute interval, of compressor operation.
2. Days of over and under lubrication.

3. Total oil consumption of compressor lube system
4. Daily and total lost dollars (US) for over lubricating.
5. Total divider block cycles,
6. Total run time of the compressor.

The Proflo PF1 monitor can store one year's worth of operating data in a first in, first out (FIFO) memory.

The FFT software can be used to reset Proflo PF1 memory. The reset time and date is recorded to the Proflo PF1's Electrical Erasable Programmable Read Only Memory, (EEPROM).

To start the download push the SET button then push the mode button 5 times until the LCD displays SEND DATA? then push the SET button. Set the FFT software to accept the Proflo PF1 data and hold the handheld computer in a position to communicate with the IrDA port. The LCD will display SENDING. If there is no device to receive the data the LCD will display FAILURE and after 30 seconds return to LAST and AVG default display.

The software provides for conversion to Microsoft Excel files for trending and graphing.

Hand held Palm operating system computers are available at most electronic or discount stores or on the Internet.

For more details on this product and other Proflo PF1 accessories, see the Ariel web at [www.arielcorp.com](http://www.arielcorp.com) and/or contact your packager or Ariel.

## Proflo PF1 Setup Alarm Time and Mode:

To setup the Alarm contact output operation, red wires, first push the SET button. Push mode button six (6) times until LCD displays SETUP?. Push SET button and the LCD will scroll to 1. SET ALARM TIME. Push and release set button to change alarm-shutdown from 30 to 240 seconds. When the compressors leave Ariel this time is set to 120 seconds. **Ariel recommends setting the alarm time to 2 times the normal cycle time rounded up to the nearest 5 seconds. This time should not be less than 30 seconds or greater than 180 seconds.** Normal design cycle time can be found on a nameplate on the lube oil pump box.

The control system must be configured to shutdown the compressor for a no-flow indication. Push the mode button, two (2) more times and the LCD will scroll to SET ALARM MODE. Push set button to toggle from N/O normally open or N/C normally closed. **Ariel recommends using the NC operation.**

After wiring mode is set the monitor will automatically return to the LAST and AVG display in 30 seconds.

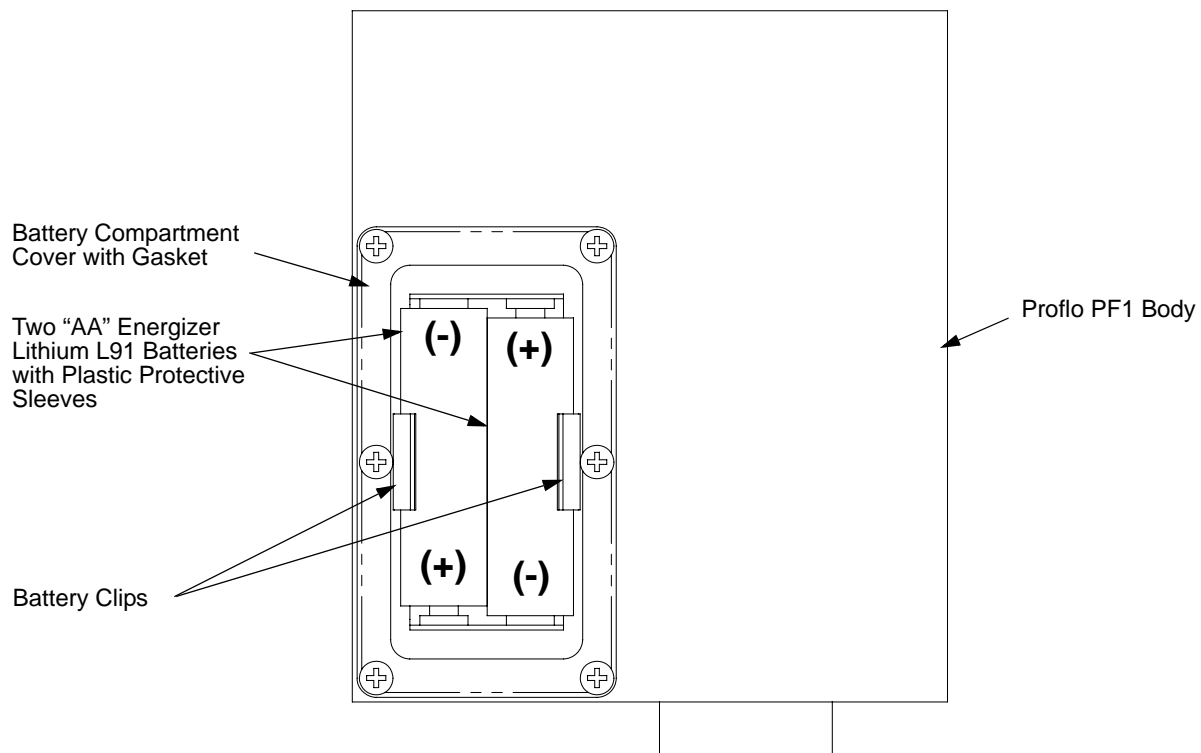
## Proflo PF1 Battery Replacement:

### CAUTION

**EXPLOSION HAZARD. DISCONNECT/LOCKOUT ELECTRICAL POWER TO CONTROL CIRCUITS BEFORE REMOVING BATTERY COVER. BATTERIES MUST ONLY BE CHANGED IN A NON-HAZARDOUS AREA.**

Battery life is expected to be 2 to 3 years (with Energizer Lithium L91) under constant normal operation.

When replacing any Proflo PF1 batteries, it is highly recommended that two (2) new AA Energizer Lithium/FeS<sub>2</sub>, model number L91 batteries be used to reduce maintenance costs. This is a true Lithium battery, where other brands might not be. While not recommended, replacement alkaline batteries can still be used when Lithium batteries are not available. Be sure that new batteries are fresh and battery cases are not scratched.



**FIGURE 4-17 PROFLO PF1 REAR BATTERY COMPARTMENT**

To replace the batteries, remove the screws, cover and gasket from the battery compartment on the back of the Proflo PF1. Remove the old batteries; remove the clear plastic pro-



ective sleeves from the old batteries and save the sleeves. Discard old batteries in a responsible manner.

Press the Proflo PF1 buttons for 45 seconds to a minute without batteries installed to dissipate the monitor's stored energy and allow for updating the battery display immediately after new batteries are installed. This step is optional as the monitor will automatically update battery display within 30 minutes of operation.

Put the plastic protective sleeves on the new batteries. Be sure that the battery negative/positive orientation to the battery compartment is correct and the batteries are tight as installed. Be careful not to scratch or damage the new battery cases during installation. Reassemble the cover, gasket and screws. Note that the cover holes will line up with the six threaded holes in the monitor body only in one direction, so be sure that it is installed properly. Attempting to install the cover upside down will result in stripping the screw threads and compromise the battery compartment seal. Do not over-tighten the (six) screws. If screws on battery cover are lost, replace with 4-40 x 3/16 inch pan head machine screws.

After the batteries are replaced and if stored energy was dissipated, press the set button once and continue to press the mode button, four times until the LCD displays BATTERY to allow the monitor to check battery voltage, reset and display the actual remaining new battery power percentage. The monitor will automatically search for the battery voltage at the next 30 minute read/write interval and update to the new battery power percentage at that time.

All trending and configuration data are stored in the Proflo PF1's EEPROM. Memory is not lost due to battery failure or battery replacement.

Component damage due to battery leakage is not normally covered under warranty.

Do not attempt to remove the front cover or warranty is void.

## Proflo PF1 Display Errors:

**ALARM** - Displayed when divider blocks are not cycling. This is normal when the divider block is not cycling. Programmed divider block cycle time has expired.

**OVERLOAD** - The Proflo PF1 electronics are protected using self-resetting fuses on the inputs. This error indicates there is a short in the wiring or the circuit is switching too large a load. To correct this, check wiring insulation for bare wires that are touching ground or each other. Insulate un-used wires or re-terminate wires. Proflo PF1 fuses will auto reset 45 seconds after a short is corrected.

**LOW BATT** - Indicates the batteries need to be changed. Refer to "Proflo PF1 Battery Replacement:" on page 4-43.

**RESET x** - This is an internal Proflo PF1 fault, the alarm condition will not be issued. The Proflo PF1 is still counting divider block cycles and controlling the inputs and outputs. When the divider block is cycling the Proflo PF1 counts pulses and measures the time between divider block cycles. At 30-minute intervals the processor takes the data stored in memory and writes this to the on board EEPROMS. If there is a problem with this the Proflo PF1 will issue a Reset error.

Try to correct the problem by:

1. Removing Proflo PF1 batteries.
2. Hold down the set button for 45 seconds. Holding the set button discharges internal capacitors and ensures a complete reset.
3. Re-insert the batteries to reboot the Proflo PF1.
  - \*If the error was a one-time problem the Proflo PF1 will reboot as normal.
  - \*If on reboot the diagnostics detect an error, the Proflo PF1 will display the constant RESET error again. Replace the Proflo PF1 and contact Ariel Corporation. Sometimes on reboot the Proflo PF1 will flash reset. This is normal.

**RESET 1** -The Proflo PF1 processor was not able to determine if the EEPROM contains valid configuration information. Reset 1 is most likely to occur after a RESET 3 is reported. Upon Proflo PF1 reboot the stored configuration data will be lost and the programmed information will need to be reentered.

**RESET 2** - The Proflo PF1 processor was not able to determine if any data has been stored or where the next data should go. Upon Proflo PF1 reboot the stored data will be lost. Configuration data will still be there and the programmed information will not need to be reentered.

**RESET 3** - This is an internal Proflo PF1 fault. The Proflo PF1 processor tried and failed three resets. The most likely cause is failure to write to the EEPROM.

**NOTE: THE MOST LIKELY CAUSE OF RESET ERRORS IS MOISTURE ON THE PROFLO PF1 CIRCUIT BOARD. SEVERAL DESIGN PRECAUTIONS HAVE BEEN TAKEN TO KEEP WATER AND MOISTURE OUT OF THE CIRCUIT BOARD CHAMBER. THESE INCLUDE:**

1. The Proflo PF1 housing has been completely sealed in a low humidity room and will survive a 2300 psi (160 bar) power wash.
2. There is a desiccant pack in the circuit board chamber.
3. The circuit boards have a protective conformal coating.

### **Proflo PF1 Operation Notes:**

1. If the alarm output is set for NC operation and the batteries are removed or go dead the Proflo PF1 will open the alarm contact. If the alarm operation is set to NO operation and the batteries are removed the alarm contact will remain in the open condition and the control system will not be told to alarm. For this reason Ariel recommends using the NC contact operation.
2. Proflo PF1 Default programmable settings.
  - This is as delivered to Ariel or reset using the FFT software.
  - Alarm trip time = 120 seconds
  - NC/NO settings = NO or non-fail safe
  - Ariel shop work instructions set outputs to:
  - Alarm trip time = 120 seconds
  - NC/NO settings = NC or fail-safe
  - Please see "Proflo Normally Open and Normally Closed Definition:" on page 4-46.
  - Also see "Proflo PF1 Setup Alarm Time and Mode:" on page 4-42.

3. Remote mounted Proflo PF1 and proximity switch. The Proflo will excite the proximity switch circuit with 3 volt battery power to detect the state of the proximity switch. Ariel has defined a maximum wire distance between the proximity switch and the remote mounted Proflo:

Maximum DistanceCondition

600 feet (183 m)Using standard Proflo PF1 batteries

10,000 feet (3050 m)Powering Proflo PF1 from other power source

The above distances are conservatively calculated based on the following assumptions/considerations:

1. Standard 22 gage instrumentation wire at 68°F (20°C) in a continuous run.

2. Not significantly degrading battery life.

No electrical noise injected into wire run.

If the Proflo PF1 is to be panel mounted, Ariel recommends removing the batteries and using the power supply from CCT. See “Proflo PF1 Accessories Available:” on page 4-49.

4. The Proflo PF1 will record any setup changes to the EEPROM.
5. The white wires on the Proflo PF1 can be used for other applications than reading divider block cycle times. The Proflo can record history of any dry contact switch. Example: history of a liquid dump valve, history of a high temperature switch, history of a valve limit switch.
6. The Proflo PF1 electronics is equipped with reverse polarity protection/correction. The electronics will automatically correct a reverse polarity output connection on both the pulse and alarm outputs.

## Proflo Normally Open and Normally Closed Definition:

There has been some confusion among PLC programmers and electrical people over the definition of Normally Open (NO) and Normally Closed (NC) as applied to the Proflo and DNFT. Most electrical components define NO or NC operation as the default state or on the shelf state. Example: A NO solenoid valve is open when the coil is not energized. When the coil is energized the valve will close. A NC solenoid valve is closed when the coil is not energized. When the coil is energized the valve will open. This logic is not used when defining the DNFT or Proflo electrical contacts. The DNFT and the Proflo use the same definition of NO and NC switch contacts. Definitions for Proflo and DNFT contact are switch states after the divider block has cycled.

**NO** = Normally Open when Running. Switch is open when the divider block is cycling. This is a non-fail-safe operation because if the unit is running and a wire falls off, the control system will not alarm/shutdown.

**NC** = Normally Closed when Running. Switch is closed when the divider block is cycling. This is the fail-safe operation because if the unit is running and a wire falls off the control system will alarm/shutdown.

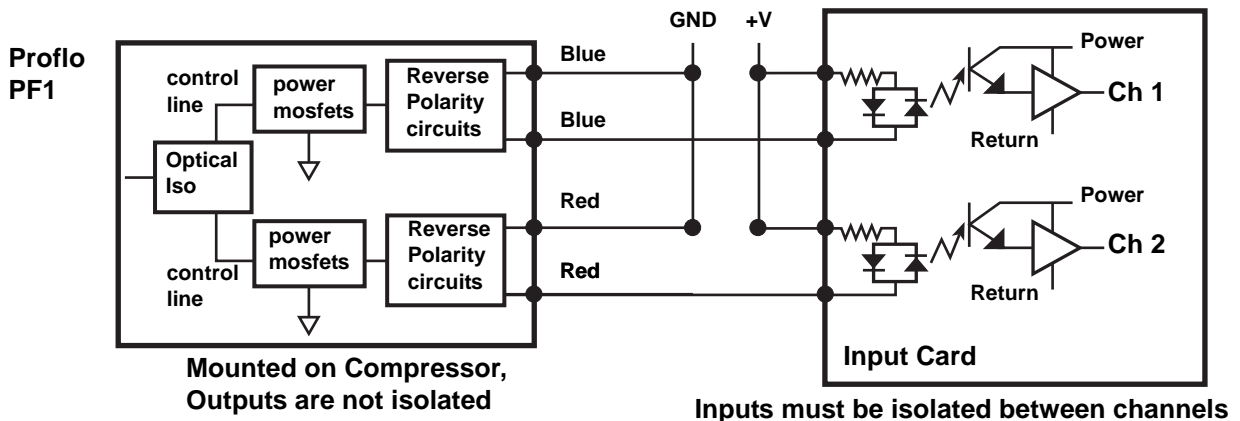
**Proflo PF1 Ariel recommends using Normally Closed (NC) configuration.** The Ariel Proflo is provided from the Ariel factory programmed for NC operation.

The reason NO and NC are defined this way is that it is easier for mechanics and operators who do not have an electrical background to understand the switch state when the divider block is cycling.

## Proflo PF1 - Using Pulse Output and Alarm Circuit at Same Time:

If the control system needs to read both the block cycling, proximity switch, and the alarm contact the following things must be taken into consideration.

1. The Proflo PF1 has an on board processor and data acquisition system (DAQ). The DAQ system records the time for each divider block cycle and stores this data to EEPROM. The data is accessible and can be downloaded through the Proflo infrared port to a Palm Operating System handheld computer with FFT software. Therefore, it may not be necessary to have the control system read and count the number of times the divider block cycles.
2. If a PLC is used to read the pulse output, the PLC may be programmed to watch for the divider block cycling and issue a shutdown if the block does not cycle for a given time. This may eliminate the need to wire to both Proflo PF1 outputs and save on field wiring connections.
3. The Proflo PF1 alarm output, red wires, and the divider block cycle output, blue wires, are not isolated from each other. If it is necessary to read both Proflo outputs, the isolation must take place on the equipment that is reading the contacts. If the PLC input card is not isolated between channels both the alarm and pulse outputs will act as the alarm contact. These contacts must also be isolated from other inputs. See Figure 4-18



**FIGURE 4-18 EXAMPLE DIAGRAM TO READ BOTH PULSE & ALARM CONTACTS**

4. If Isolated inputs are not an option, another way to achieve the output signal isolation is to connect the alarm/shutdown contact to the safety system and install another proximity switch for the control system to read and calculate oil consumption. Refer to the "Proflo PF1 accessories" section below for a proximity switch part number.
5. If Isolated PLC inputs are not an option, yet another method of achieving isolation between the Proflo PF1 outputs and the PLC is to wire the Proflo to the "coil" side of a relay. Then use the contact side of the relay to the control system. There are relays on the market that are very cost effective. Ariel recommends using a solid state type relay for long life. See Figure 4-19

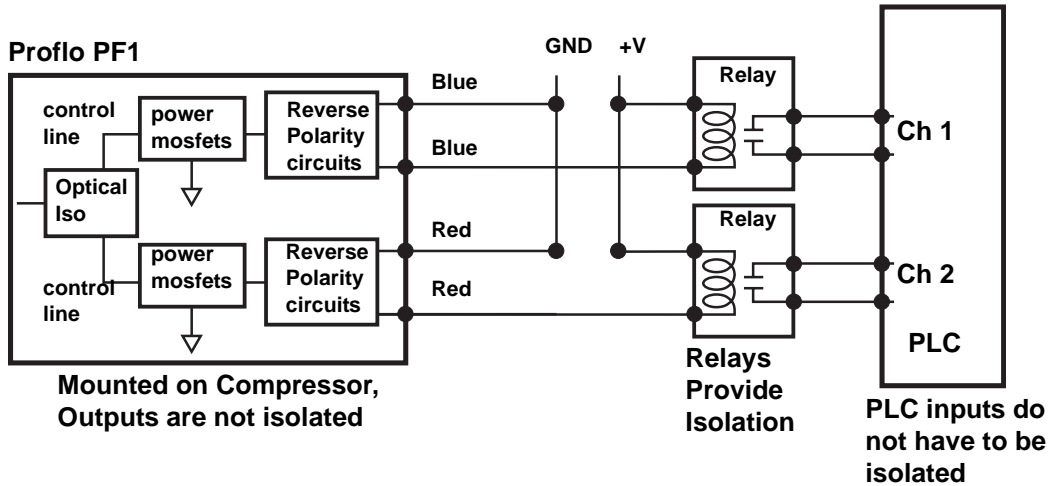


FIGURE 4-19 EXAMPLE DIAGRAM TO READ BOTH PULSE & ALARM CONTACTS - USING RELAYS

Some relays may require a current limiting resistor to keep from shorting the power supply through the relay coil. Many relays have a built in current limiting circuit. It is the responsibility of the control system designer to choose proper relay components.

### Proflo PF1 - Using PLC to Calculate Oil Consumption:

Using the blue wires or the pulse output, it is possible for the control system to calculate the amount of oil the system uses. Following is an example of how to do this.

TABLE 4-13 EXAMPLE DIVIDER BLOCK:

BLOCKS	IN <sup>3</sup>	X 2
12T	0.012	0.024
18T	0.018	0.036
18T	0.018	0.036
6S	0.006	0.012
18T	0.018	0.036

$$0.144 \times 0.0346 = 0.004987 \text{ pints/cycle}$$

Blocks are numbers stamped into the divider blocks mounted on the compressor.

Block numbers divided by 1000 = volume, In<sup>3</sup> (cubic inches).

x 2 are for each block moving in 1 full cycle.

0.0346 is the conversion from in<sup>3</sup> to pints, US liquid (pints/in<sup>3</sup>).

(Divide pints by 8 = gallons, US liquid)

(Multiply gallons (US liquid) X 3.78541 = liters)

(Multiply pints (US liquid) X 0.47318 = liters)

The above calculation can be entered as a constant for each Proflo PF1.

The PLC can then calculate a running total by adding 0.00497 pints, in this example, to a to-

talizer the whole time the compressor is running. This information can be used to track how much oil the compressor is using.

## **Proflo PF1 Accessories Available:**

The following parts are available.

1. AC power supply for panel mount.  
Panel mount power supply is for safe area only.
2. Panel mount kit. This kit includes the panel mount bracket and a proximity switch.
3. Relay interface module. Use this module if you want to switch an AC load 120/240 VAC @ 10 Amps.
4. Additional proximity switch.
5. Palm interface Fluid Flow Trending (FFT) software.

For more details on the Proflo PF1 and available accessories, see the vendor literature on the Ariel web site at [www.arielcorp.com](http://www.arielcorp.com) and/or contact your packager or Ariel.

## **Protection of Electronics & the Compressor When Arc Welding**

Any arc welding on the skid and/or associated equipment and piping can permanently damage solid-state electronic equipment. Welding can cause immediate failure or reduced life of such electronic equipment.

Protect the force feed lube flow monitor(s) prior to doing any arc welding (including repair welding) as follows: Disconnect all connections to the flow monitor including ground, and remove the batteries. Or completely remove the flow monitor from the compressor.

It is good practice to attach the welding ground clamp as close as possible to the area where the welding will occur and to use the lowest practical welder output setting. Welding must not cause a current flow across any compressor bearing surface, including but not limited to crankshaft and crosshead bearing surfaces.

## **Electronic-Lubricator Digital No-Flow Timer Switch (DNFT)**

When an Ariel DNFT microprocessor-based switch is supplied, it is used to sense no-flow or slow-flow conditions in the compressor cylinder lubrication system to facilitate alarm and/or shutdown. The DNFT also contains an amber light-emitting diode (LED) cycle indicator to provide a positive visual indication of system operation. The Ariel DNFT includes a proximity switch. The Ariel DNFT, usually supplied, is factory set for (3) three minutes from no-flow to alarm/shutdown signal and is not adjustable. Optional programmable models are also available. Introduced in September of 1996, the DNFT replaced the traditional mechanical no-flow switch and is optional on all new units. Since its introduction, the DNFT has undergone

a series of design enhancements and several versions are in service. The current DNFT is shown in Figure 4-20

The DNFT works through a magnetic pin which cycles back and forth as the divider valve piston moves, flashing the amber LED and indicating a complete cycle of the divider valve. The DNFT operates on a field-replaceable lithium battery. If battery voltage drops below normal operating levels, the DNFT goes into shutdown mode and compressor can not be re-started until battery is replaced.

## Replacing the (Field-Replaceable) Battery in the DNFT:

1. Shut down the compressor
2. Disconnect wiring and loosen set screws. Remove DNFT housing to a safe atmosphere.
3. Use 3/8 inch ratchet wrench to remove the pipe plug.
4. Remove battery from the DNFT and disconnect from the polarized connector.
5. Connect the new battery (Ariel part number A-10807 or Radio Shack 960-0418) to the attached polarized plug.
6. Reinsert the battery and reinstall pipe plug.
7. Replace DNFT control housing on the magnet housing to original position and tighten set screws. Reattach wiring and conduit.
8. Verify the DNFT is working by pre-lubing the system and check for LED blink

See the Ariel web site - vendor literature - Whitlock for more details on DNFT's.

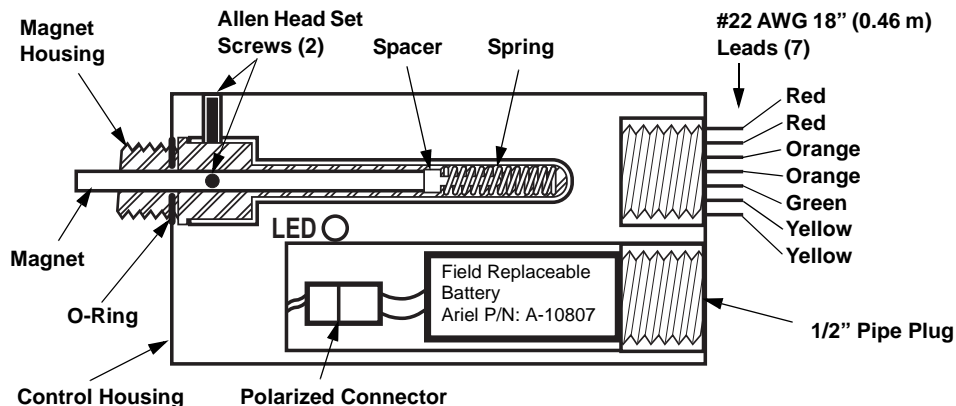


FIGURE 4-20 DIGITAL NO-FLOW TIMER SWITCH - (DNFT)

## Oil Head at Lube Points

The force feed system provides a minimum of 1-inch (25 mm) of oil head at lube points to extend check valve life. Where the 1-inch (25 mm) of head is not inherent, an oil trap fitting is provided, see the Figure.

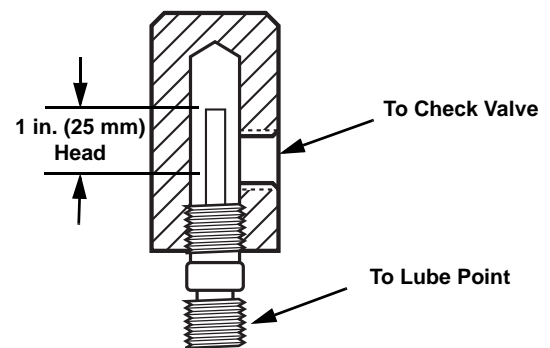


FIGURE 4-21 OIL HEAD TRAP FITTING

**NOTE: PRESSURE IN FORCE FEED LUBE LINES IS, AS A MINIMUM, 110% OF THE CYLINDER SUCTION GAS PRESSURE.**

## Force Feed Lubrication System and Running Conditions

### Force Feed Lubrication System

1. Check sight glass on lubricator reservoir to make sure it is properly filled with oil. The oil in the reservoir is used to lubricate the worm gear and cam; it does not flow through the system. The reservoir also catches lube pump overflow. Oil is added only if it becomes necessary to raise the reservoir oil level.

TABLE 4-14 FORCE FEED LUBRICATOR RESERVOIR OIL CAPACITY

LUBRICATOR TYPE - ARIEL DESIGNS	US GALLONS	LITERS
Single Pump	0.25	1
Dual Pump	0.5	1.75
Four Pump	0.8	3

2. The force feed system has been filled with mineral oil at the factory. If piping has been removed, or if the system has been drained, it can be filled and primed through a 1/8 inch plug on the discharge end of the lubricator pump.
3. Prime the force feed lubrication system just prior to starting the compressor using a proper priming pump; refer to "Ariel Tools - Purchased Separately" in Technical Manual Section 7. Use clean force feed lubricating oil of same type and grade as being used in service. Do not use any other type or grade of fluid for priming.
4. If the unit has just been overhauled, adjust the lubricator for maximum delivery. Reference Technical Manual Sections 3 and 5. Loosen the adjusting screw locknut. Turn the plunger stroke adjustment screw to the full up position. Tighten the adjusting screw locknut. Proper feed rate may be set after the machine is started.
5. When there are two or more pumps manifolded and feeding one distribution block, the best way to adjust them is equally. Start with pumps wide open, and adjust them together so that when the break-in cycle time is set, the pumps are stroking about the same. After break-in period, adjust the pumps in the same



manner, provided that the final pump stroke is not too short. Try and keep the stroke greater than 20% of maximum; if set for less, the pump is not very reliable. If need be, one pump can be closed to stop its flow and the other pump(s) opened to make the “normal” cycle time, to maintain a stroke greater than 20% in the functioning pump(s).

## Running Conditions

When the machine is running, make sure that the oil level in the lubricator reservoir is at least one-half way up the sight level, but does not exceed two-thirds.

See your packager's specific data to determine the normal operating conditions, the cylinder working pressures, and the rated speed.

## System Design Considerations and Operating Parameters

To optimize force-feed lubrication system operation, Ariel uses the following general guidelines:

1. Maintain lube ratios within prescribed limits and cycle times as low as possible (normally 10 sec minimum) to provide each point with lubrication as frequently as possible.
2. Multiple pumps with manifolding are used to ensure that 150% of the normal lubrication rate can be provided during break-in.
3. Pumps are not allowed to operate below 20% of full stroke, the point at which they become unreliable.
4. In some applications, to optimize operation of the lubrication system, a single divider section is used to deliver lubrication to both a packing and a cylinder.
5. In some applications, cross-porting of divider valves is used to deliver the proper proportion of lubricant to a given point.

## Force Feed Balance Valves

Balance Valves may be used in high differential-pressure distribution-block applications to reduce system problems such as bypassing, no-flow switch errors or blown rupture discs. The force feed balance valve is shown in the Figure.

## Setting and Maintaining Balance Valves

Balance valves cannot be set prior to operating the unit. Ensure that all fittings are tight and any known leaks have been fixed.

Purge the force feed lube system with a high-pressure hand pump, using the same injection oil that is used in service, to remove any trapped air or gas in the system. See Technical Manual Section 7 for pump illustration and part number. DO NOT



**FIGURE 4-22 FORCE FEED  
BALANCE VALVE**

**USE ANY OTHER FLUIDS FOR PURGING!**

Start up the compressor and bring up to normal operating pressure. After the operating pressures have stabilized, adjust the cap on the top of the balance valve if necessary. Loosen the locking nut on the top of the balance valve directly under the cap. Turn the cap clockwise to increase the pressure and counter clockwise to decrease the pressure. Retighten the locking nut against the cap.

Set the balance valves and maintain at approximately same pressure on each pressure gauge in the injection lines of the pump system affected. A system should be set and maintained within 500 psi (3400 kPa) total or less. The closer the individual line pressures are maintained, the more reliable the system will become.

Once the balance valves have been set, they should be checked 4 to 6 hours later to ensure the pressures have not changed and caused another imbalance. If readjustment is necessary the gauges should be checked again in 4 to 6 hours. If a pressure gauge in a line with a balance valve is reading more than 500 psi (3400 kPa) higher than the others, try to reduce the pressure on that particular injection line. If reducing the balancing pressure on the balance valve does not drop the pressure, then the other balance valves will need to be adjusted to match the highest pressure.

To set balance valves equipped with a distribution block inlet gauge only:

1. Start up the compressor and bring up to normal operating pressure. After the operating pressures have stabilized, with all balance valves backed off (zero spring load), note the highest gauge pressure reached in a complete block cycle.
2. Slowly increase the spring load on one balance valve, being careful to not exceed rupture disk rated pressure. Watch the gauge and if the maximum pressure increases, reduce the spring load until the highest pressure falls to the pressure noted in step 1, above. Tighten the lock nut against the cap, hand wrench tight.
3. Repeat step 2, for the remaining valve(s).

Maintain the system by recording the pressures and cycle times of the lubrication system at least once a day.

## Checking/Adjusting Balance Valves on Subsequent Start-up

Be sure that all fittings are tight and any known leaks have been fixed. Purge the force feed system with a purge gun (hand pump kit, available from Ariel purchased separately), using the same injection oil that is used in service.

Start the compressor and bring up to normal operating pressure. After the operating pressures have stabilized, check the pressure gauges to ensure the system is still balanced. If one or more line pressures are out of balance, wait for 2 to 3 hours to see if they become balanced. DO NOT adjust the balancing valves immediately. It is possible that some lube points will increase in injection pressure after a short period of run time and the system will become balanced if it is not balanced on start up.

If a balance valve(s) was installed, but is not required, leave (or set) the spring adjustment at zero. If back-pressure on an unused balance valve is high enough, it may eventually begin

to leak oil. In this case, replace the balance valve internal assembly with a plug assembly, Ariel Part Number A-10330. DO NOT RUN UNIT WITH LEAKY BALANCE VALVES. A valve seal repair kit, Ariel Part Number A-8005-K, is also available.

Maintain the system by recording the pressures and cycle times of the lubrication system at least once a day. Readjust valves as required to keep pump systems pressure balanced for best results.

## Frame Lubricating System - Description

The frame lubricating system supplies oil to the internal frame running gear. The cylinders are supplied with lubrication by the force feed system (see "Force Feed Lubrication System - Description" on page 4-31). The oil level regulator outside of the crankcase, or separate oil sump in the case of a dry sump crankcase, maintains the proper oil level in the sump.

Frame lubrication is drawn from the sump through the suction strainer into the oil pump that is mounted on the crankcase auxiliary end cover. The pump's discharge is piped to an oil cooler mounted on the compressor skid and is temperature controlled with a thermostatic control valve. Oil returns from the cooler to the oil filter mounted on the auxiliary end of the crankcase. Pressure gauges are provided on the filter inlet and outlet. Normal pressure drop through a clean filter is 2 to 6 PSID (0.15 to 0.4 bar<sub>d</sub>), at normal operating temperature.

From the filter, oil travels through a pressure regulator to an oil gallery cast in the crankcase and running the length of the crankcase.

Drilled holes from the gallery through the bearing saddles deliver oil to the crankshaft bearings.

Passages drilled diagonally through the crankshaft from the crank journals to the crank pins deliver oil to the connecting rod bearings.

Holes drilled through the length of the connecting rods deliver oil to the connecting rod bushing.

Oil travels from the bushing through holes drilled in the middle of the crosshead pin to the hollow crosshead pins, and from there to the crosshead bushings.

Drilled passages from the oil gallery deliver oil at full system pressure through external tubing to lubricate the top and bottom of each crosshead. Run-off from the shoes, crosshead, and connecting rod bushings collects in the crosshead guide and drains back to the crankcase.

## Lube Oil Strainer, Filter & Filter Installation Instructions

### Lube Oil Strainer

The strainer is located on the auxiliary end of the crankcase below the oil level. It is provided to protect the oil pump from debris that might cause damage. The strainer basket should be taken out and washed in an appropriate solvent whenever the lubricating oil is changed. For dry sump frames the lube oil strainer is shipped loose (not installed) from the Ariel factory.

## Lube Oil Filter

Ariel recommends replacing the lube oil filter every 6 months, or 4000 hours, or when oil filter differential pressure reaches the value given in Table 4-15 or on the oil filter information plate located on the compressor frame top cover, at normal operating temperature; whichever comes first. Also clean the sintered element in the small oil filter supplied on the force feed lubrication system on the same schedule or every time main oil filter is changed.

**TABLE 4-15 MAXIMUM DIFFERENTIAL PRESSURE TO CHANGE OIL FILTER OR ELEMENT(S)**

TYPE FILTER	MAXIMUM $P_D$ TO CHANGE FILTER <sup>A</sup>	
	PSID	bar <sub>g</sub>
Spin-On Filter	10	(0.7)
Cartridge Type Element(s)	15	(1.0)

- a. Or every six months, or 4000 hours, whichever comes first.
2. On start-up differential pressure may exceed the tabled limits until the oil reaches operating temperature.

## Oil Filter Installation for Spin-On Type Filters

1. For compressors supplied with spin-on type oil filters, remove the old filter by unscrewing it, with the compressor stopped. Be sure that the old filter gasket is removed. Clean the filter manifold base surfaces.
2. Fill a new filter with clean oil, using the same grade and type of oil as in the sump.
3. Apply clean oil to the filter gasket.
4. Screw on the new filter, after the filter gasket contacts the base tighten one full turn.
5. After starting the compressor, check for leaks and retighten the filter if necessary.
6. Do not run the compressor with a damaged filter canister. It can fracture or leak.
7. Replace the filter only with an Ariel approved non-bypass type filter.

## Oil Filter Element Installation for Cartridge Type Filters

1. For compressors supplied with cartridge type oil filters, remove the filter vessel drain plug and completely drain the vessel, with the compressor stopped.
2. During draining, remove the flowing vent line and 1/16 in. (2 mm) orifice fitting and blow out the line with compressed air. Clean the orifice with a 1/32 in. (1 mm) diameter wire or a standard paper clip (20/21 gage wire). Loosen the nuts and remove the top cover.

**NOTE: REMOVAL OF THE ELEMENT PRIOR TO COMPLETELY DRAINING THE VESSEL WILL ALLOW TRAPPED DEBRIS TO ENTER THE OIL HEADER AND CAN CAUSE SEVERE DAMAGE TO THE COMPRESSOR.**

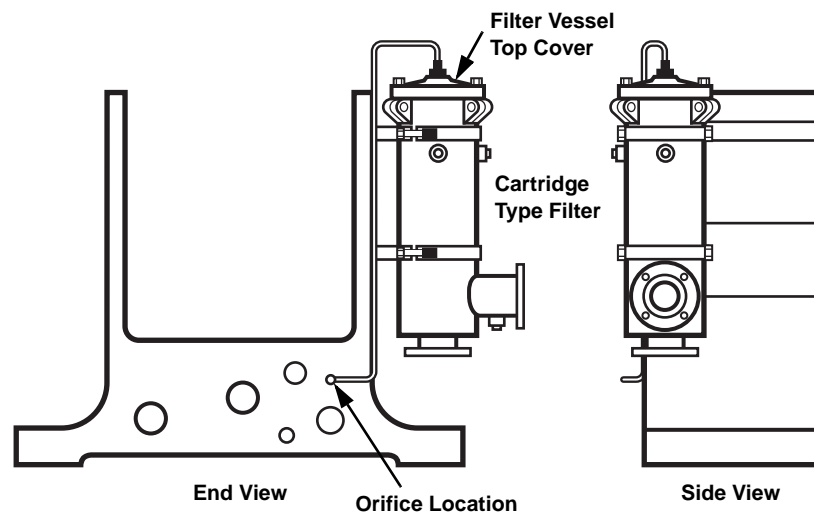
3. After the oil has completely drained, remove the spring plate assembly, strainer

tube and old filter element. Inspect the interior of the vessel and clean it as required.

4. Visually inspect the interior/exterior of the new element to be sure that it is not damaged and is free of any packaging materials.
5. Place the new element over the seat in the bottom of the vessel.
6. Insert the strainer tube and install the spring plate assembly.
7. Inspect the top cover O-ring and replace if damaged. Install the cover and tighten hold down nuts to 70-80 lb-ft (95-110 N·m) torque.
8. Install the flowing vent line and orifice, and tighten the fittings.
9. Install and tighten the filter vessel drain plug. Fill the vessel with oil, using the prelude system. Check the oil pressure gauges to be sure the vessel is full.

**NOTE: FAILURE TO FILL THE FILTER VESSEL WITH OIL PRIOR TO STARTING, CAN CAUSE SEVERE DAMAGE TO THE COMPRESSOR.**

10. After starting the compressor, check for oil leaks. Fix any leaks.
11. Replace the filter element only with an Ariel approved type element.



**FIGURE 4-23 OIL FILTER FLOWING VENT TO PREVENT AIR ENTRAPMENT - TYPICAL**

## Lube Oil Pump & Lube Oil Pressure

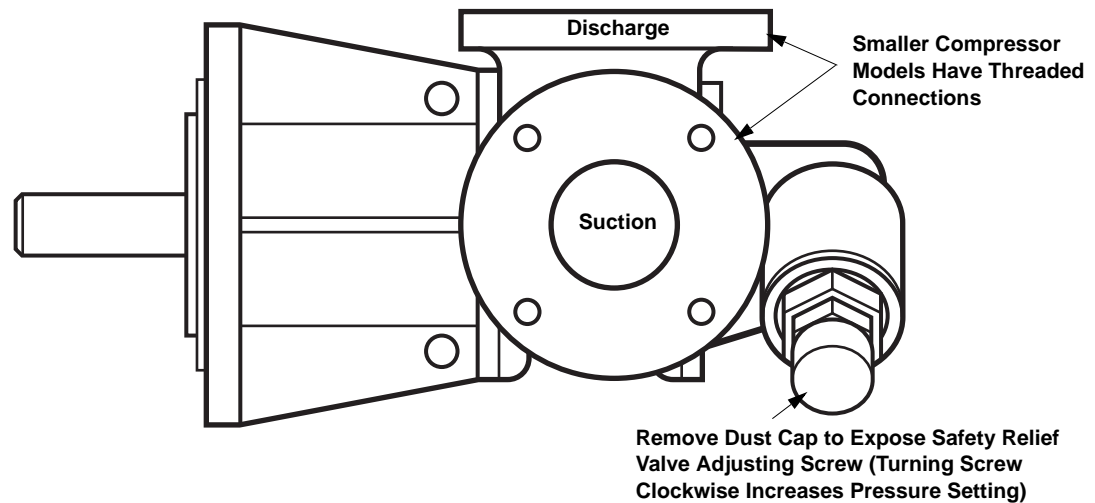


FIGURE 4-24 LUBE OIL PUMP - TYPICAL

### Description & Adjustment

If there is a separate regulating valve down stream from the pump, the spring-loaded safety relief valve within the pump head is set at the Ariel factory on a new compressor to the maximum pressure with the adjusting screw turned in all the way. Even though the adjusting screw is turned in all the way, the relief valve will still open at approximately 100 psig (7 bar<sub>g</sub>) to protect the pump from high pressure damage. In this case, do not adjust the pump safety-relief valve unless installing a new pump, then set the relief valve to maximum pressure by turning the adjusting screw clockwise in all the way.

If there is no separate regulating valve, the pump safety relief valve is set by the Ariel factory on a new compressor to regulate pressure at 60 psig (4.1 bar<sub>g</sub>) into the compressor when crankshaft speed equals or exceeds minimum normal operating speed. If oil pressure into the compressor while running at minimum operating speed and normal operating temperature does not read approximately 60 psig (4.1 bar<sub>g</sub>), adjust the pump safety relief valve. With compressor running at minimum rated speed, remove the dust cap and adjust the screw to provide oil pressure into the compressor at 60 psig (4.1 bar<sub>g</sub>). Turning the adjustment screw clockwise increases the pressure setting.

### Lube Oil Pressure Regulating Valve

If there is a separate lube oil pressure regulating valve, normal oil pressure into the compressor is set at the regulating valve by the factory at 60 psig (4.1 bar<sub>g</sub>) when crankshaft speed equals or exceeds minimum normal operating speed.

**NOTE: IF OIL PRESSURE DROPS BELOW 50 PSIG (3.5 bar<sub>g</sub>) WHEN CRANKSHAFT SPEED EQUALS OR EXCEEDS MINIMUM RATED OPERATING SPEED, THE CAUSE MUST BE FOUND AND CORRECTED.**

## Low Oil Pressure Shutdown

The low oil pressure shutdown is normally mounted by the packager and is supplied to customer specifications. Ariel provides an oil pressure pickup fitting on the oil gallery located after the cooler and filter. The electric or pneumatic oil pressure switch is to be set to actuate when oil pressure falls below 35 psig (2.4 bar<sub>g</sub>). An alarm set to actuate when oil pressure falls below 50 psig (3.4 bar<sub>g</sub>) is desirable.

### NOTE:

- 1. THE COMPRESSOR MUST HAVE A WORKING LOW OIL PRESSURE SHUTDOWN. WHEN SHUTDOWN AS RESULT OF LOW OIL PRESSURE, DO NOT ATTEMPT TO RE-START UNTIL FAULT IS FOUND AND CORRECTED.**
- 2. DO NOT ATTEMPT TO ADD OIL TO THE CRANKCASE THROUGH THE BREATHER HOLE WHILE THE UNIT IS RUNNING. THIS WILL CAUSE OIL FOAMING, AND UNNECESSARY NO-FLOW SHUTDOWNS IN THE FORCE FEED LUBRICATION SYSTEM.**
- 3. WHEN THE FORCE FEED LUBRICATION SYSTEM HAS A COMMON SUPPLY (FROM THE CRANKCASE), IT IS CONSTANTLY USING OIL FROM THE CRANKCASE, A WORKING OIL SUMP LEVEL CONTROLLER IS NECESSARY. THIS MUST BE DESIGNED TO ALLOW OIL TO FLOW INTO THE CRANKCASE FROM AN OVERHEAD TANK AT ALL AMBIENT TEMPERATURE CONDITIONS.**

## SECTION 5 - MAINTENANCE

### General Introduction

The major components of the frame assembly are the frame (or crankcase) with integral crosshead guides, crankshaft and bearings, connecting rods, chain drive system and crossheads.

A cast-in oil gallery runs the length of the crankcase. Drilled oil passages feed lubricating oil to the running gear.

The removable top cover on horizontally opposed models, (and connecting rod and chain access covers on the JGI), and crosshead guide side covers provide generous access for inspecting and removing internal components. The top cover is made of aluminum for easy handling.

Absolute cleanliness, including the use of lint-free wiping cloths, is a necessity during any maintenance on the compressor. When access covers have been removed, keep the frame covered to protect the interior from dust except when actually working on it. Any components that have been removed should be protected from falling objects that might mar or chip running surfaces.

Whenever the machine is dismantled, gaskets at non-pressure positions are to be carefully inspected before reuse. Damaged gaskets must be replaced. Gaskets at pressure locations should be replaced. Before installing a gasket, apply an antiseize lubricant to both sides or to the metal seating surfaces. This will help to hold the gasket in place during assembly and aid in easy of removal.

If replacing any major reciprocating component, that is; a connecting rod assembly, piston, piston and rod assembly, crosshead-balance nuts or crosshead, weigh component parts and compare to the Compressor Balancing Record sheet that comes in the parts manual with each compressor. If there are weight changes, recalculate opposing throw reciprocating



weight differential, refer to “Opposed Throw - Reciprocating Weight Balancing” on page 1-5.

 **CAUTION**

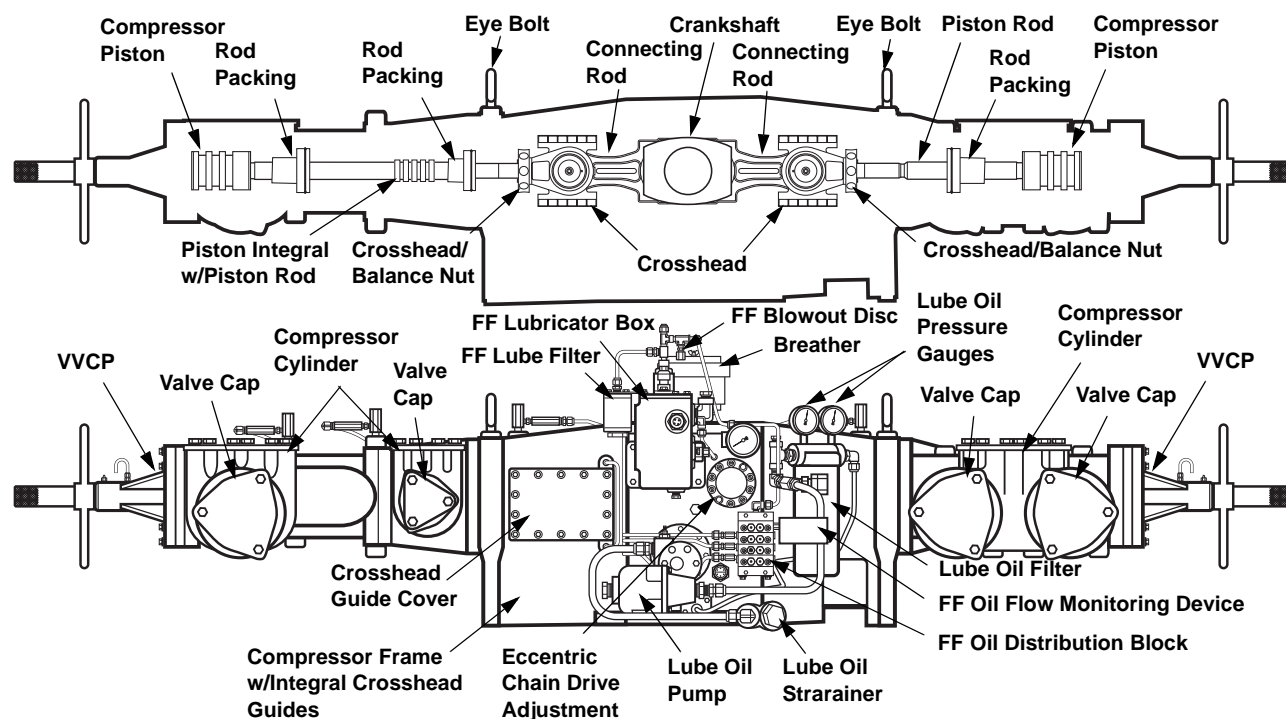
TO PREVENT PERSONAL INJURY, BE SURE THAT COMPRESSOR CRANKSHAFT CANNOT BE TURNED BY THE DRIVER OR COMPRESSOR CYLINDER GAS PRESSURE DURING MAINTENANCE: — ON ENGINE-DRIVEN COMPRESSORS, REMOVE THE CENTER COUPLING OR LOCK THE FLYWHEEL. — ON ELECTRIC MOTOR-DRIVEN COMPRESSORS, IF IT IS INCONVENIENT TO DETACH THE DRIVER FROM THE COMPRESSOR, THE DRIVER SWITCH GEAR MUST BE LOCKED OUT DURING MAINTENANCE.

BEFORE STARTING ANY MAINTENANCE OR REMOVING ANY COMPONENTS, RELIEVE ALL PRESSURE FROM THE COMPRESSOR CYLINDERS. (REFER TO PACKAGER’S INSTRUCTIONS FOR COMPLETELY VENTING THE SYSTEM.)

 **CAUTION**

AFTER PERFORMING ANY MAINTENANCE, THE ENTIRE SYSTEM MUST BE PURGED WITH GAS PRIOR TO OPERATION, TO AVOID A POTENTIALLY EXPLOSIVE AIR/GAS MIXTURE.

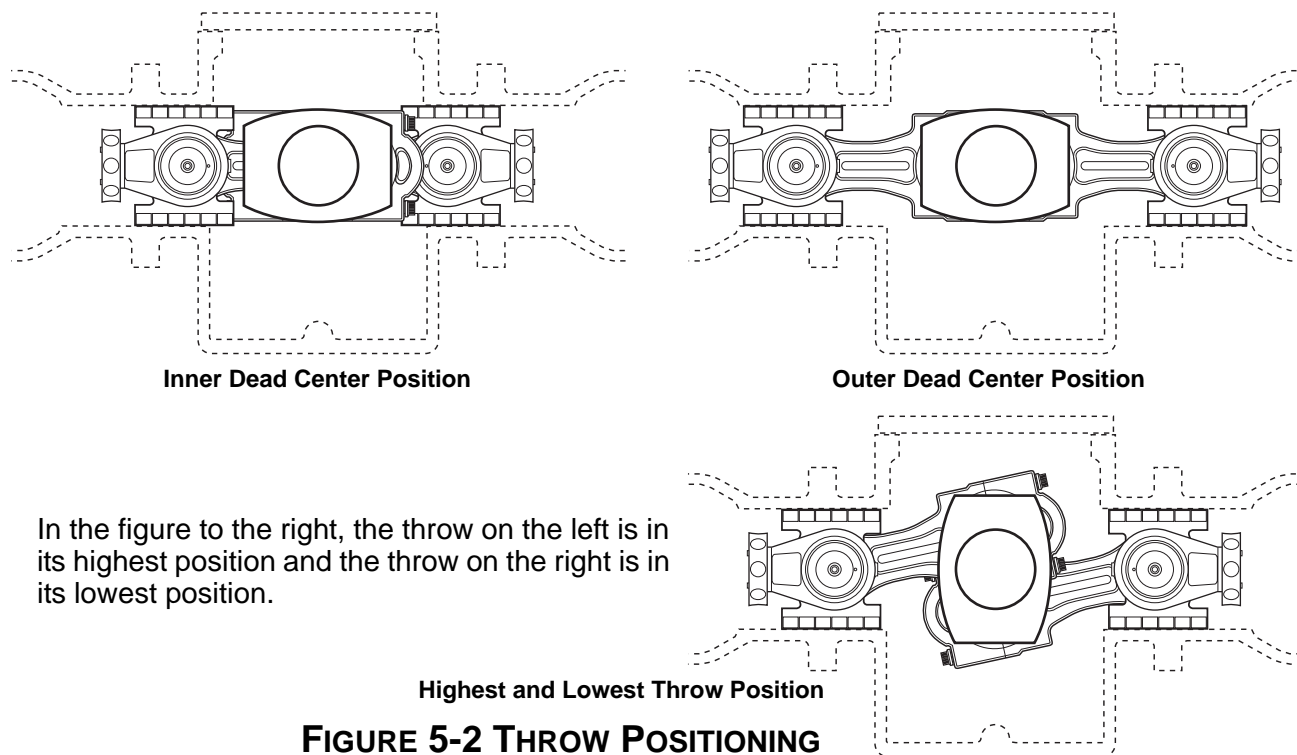
## Compressor Components



**FIGURE 5-1 COMPRESSOR COMPONENTS - TYPICAL JGM:N:P:Q**

## Positioning a Throw for Maintenance

Compressor maintenance often requires manually turning the crankshaft to locate a particular throw in one of two positions: the inner dead center or the outer dead center. During normal operation, the crossheads slide back and forth in the crosshead guides. In the inner dead center position, the crossheads slide in toward the crankcase as far as possible. In the outer dead center position, the crossheads slide out away from the crank case as far as possible (see figures below). Some procedures, such as setting piston clearances, require a dial indicator with magnetic base to locate the precise inner or outer dead center.



In the figure to the right, the throw on the left is in its highest position and the throw on the right is in its lowest position.

**FIGURE 5-2 THROW POSITIONING**

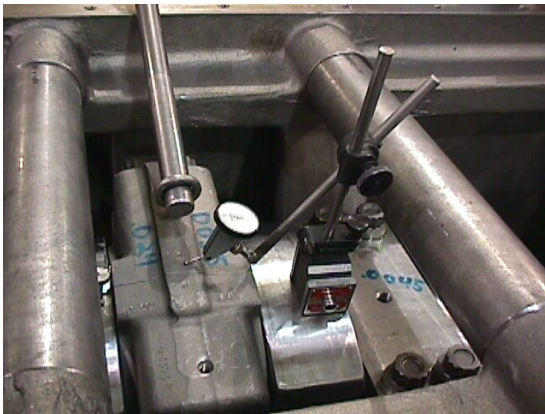
## Connecting Rod

### Connecting Rod (Crank Pin) Bearing

This bearing is a tri-metal (steel, bronze, and babbitt with a tin flash coat) precision split (2-shell) bearing. There are notches in the rod and rod cap for the bearing tabs in order to position and maintain the position of the bearing halves.

1. Do not remove the connecting rod cap to check for bearing wear, if cap is removed it is recommended that a new bearing is installed, i.e. **DO NOT REUSE BEARING SHELLS**.
2. Determine bearing wear by checking actual jack and side clearances against the clearance limits given in Table 1-3 on page 1-10 and the last bearing clearance check values, if available. High copper content in the oil analysis may be an indication of main and/or connecting rod bearing wear, and/or chain idler, cross-head, connecting rod bushings wear (excessive use of anti-seize lubricates can also elevate copper content in the oil analysis).
3. After installing a new bearing(s), check jack and side clearances against the clearance limits. Record values on a copy of from on Page 5-48.
4. Use calibrated dial indicators with 0.0005 inches (0.005 mm) increments and magnetic stands to check clearances.
5. Check Jack clearance as follows:
  - a. As shown in Figure 5-3 on page 5-5, turn crankshaft pin up to the highest throw position, install a magnetic stand on the top of adjacent crankshaft web, with a needle type dial indicator placed against the top of the connecting rod near the cap seam. Set indicator to zero.

- b. Pry connecting rod up, use an appropriate bar to pry against the frame and on an eye bolt installed in the rod, until needle on the face of the dial indicator stops moving. repeat to be sure the reading is accurate.
6. Check thrust clearance as follows:
  - a. As shown in Figure 5-4 on page 5-6, install a magnetic stand on the side of crankshaft web, with a button type dial indicator placed against the side of the connecting rod.
  - b. Use an appropriate pry bar to pry against the crankshaft web and thrust connecting rod (do not pry on rod cap) tight toward dial indicator. Release pressure on pry bar. Hold rod in place with minimum pressure to keep it from moving. Set dial indicator to zero. Then pry on the connecting rod to thrust it tight in the opposite direction and release pressure. Hold rod in place with minimum pressure to keep it from moving to determine thrust clearance. Repeat to be sure reading is accurate.
7. Be sure to remove eye bolts, magnetic stands, dial indicators and pry bars after taking readings.



Dial Indicator Magnetic Stand Placement on Top of Crankshaft Web, & Showing Eye Bolt and Pry Bar



Needle Type Dial Indicator Placement on Top of Connecting Rod



Using Pry Bar to Check Jack Clearance

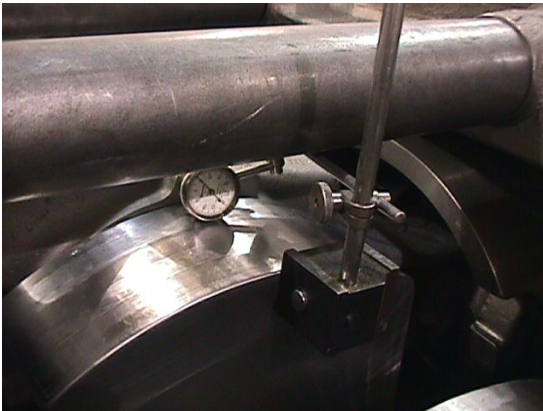
**FIGURE 5-3 MEASURING CONNECTING ROD BEARING VERTICAL JACK CLEARANCE - TYPICAL**



8. Check the part number on each connecting rod when ordering and installing bearings to be sure that the bearing part numbers being installed are compatible with the connecting rod.

**NOTE: DO MIX BEARING SHELL PART NUMBERS ON AN INDIVIDUAL CONNECTING ROD. BOTH HALF SHELLS MUST HAVE THE SAME PART NUMBER.**

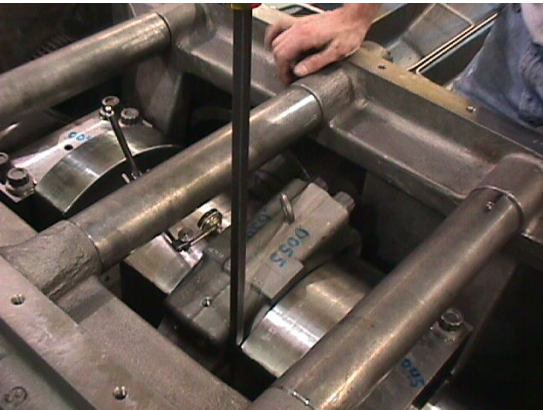
9. Connecting rods need not be removed from the compressor to replace the crank pin bearings.
10. Refer to "Connecting Rod - Installation" on page 5-8 for bearing shell installation. If clearance readings are not within tolerance after installing new bearings, contact your packager or Ariel before proceeding.



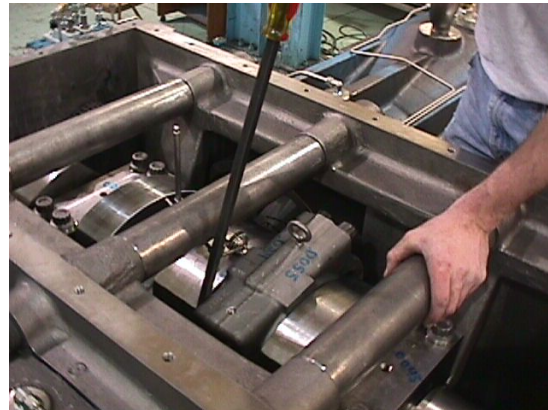
Dial Indicator Magnetic Stand Placement



Button Dial Indicator Placement



Rod Thrust Tight Toward Dial Indicator



Rod Thrust Tight Away from Dial Indicator

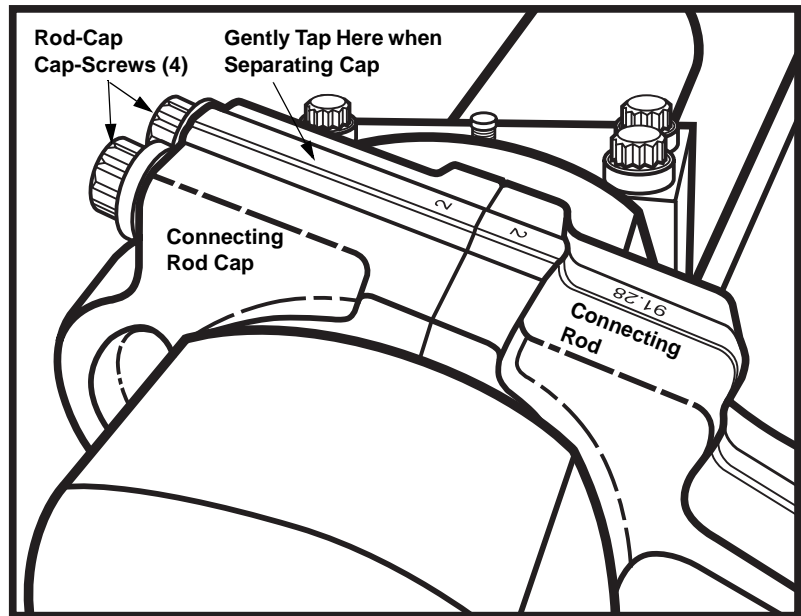
## FIGURE 5-4 MEASURING CONNECTING ROD THRUST (SIDE) CLEARANCE - TYPICAL

### Connecting Rod - Removal

1. Remove the top cover from the crankcase (connecting rod and chain access covers on the JGI) and the side covers from the crosshead guides.
2. Remove the piston and piston rod as described in "Piston and Rod" on page 5-27.
3. Move the throw to near the outer dead center position.
4. Remove the crosshead as described in "Crosshead - Removal" on page 5-11,

while supporting the connection rod so that it does not drop.

5. Turn the crankshaft until the throw is near to its highest point position. Completely loosen the connecting-rod-cap bolting and remove the top two cap-screws.
6. Separate the rod cap from the rod. Use the bottom two rod-cap cap-screws as a handles to pull on the bottom of the rod cap while tapping the top face of the rod cap with a semi-soft faced hammer. Do not pull or strike the rod cap too hard; it may break the rod cap dowels. Work the rod cap away from rod as evenly as possible. Separating the two parts unevenly may break the rod cap dowels or cause them to bind in the rod dowel holes. See Figure above.



**FIGURE 5-5 ROD AND ROD CAP SEPARATION**

7. Remove the rod cap and its bearing half shell.
8. The bearing shell may fall out when separating the connecting rod and cap from the crankshaft pin. If bearing shells do not come loose, rotate/slide them out of the connecting rod and/or cap.
9. Turn the crankshaft throw to near the inner dead center position and remove the rod through the crosshead guide opening (or connecting rod access hole on the JGI).
10. After the removal of the connecting rods, be sure to protect the crank pins from being nicked or scratched.

**NOTE: IF ALL CONNECTING RODS ARE TO BE REMOVED, IT MAY BE MORE EXPEDIENT TO REMOVE THE CRANKSHAFT PRIOR TO REMOVING THE RODS.**

## Connecting Rod Bushing Replacement

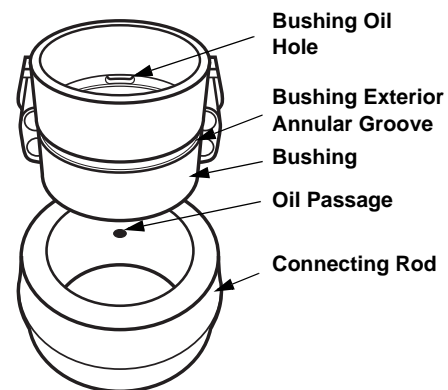
1. Check crosshead pin to connecting rod bushing clearance (see Table 1-3 on page 1-10 for recommended clearance.) Inspect the pin for wear and replace it if necessary.
2. To replace a rod bushing file or hack saw the existing bushing to reduce the tightness of the shrink fit. From the inside diameter file or saw across the length of the bushing to within 1/32 inch (1 mm) of its radial thickness. It can then be easily drifted out. Be careful, not to file or saw into the connecting rod, **as any rod bore damage makes the rod unusable.**
3. Use a hydraulic press in a qualified machine shop to install the new bushing. Do not hammer the bushing into place as this distorts the bushing bore. Before

installation, cool the new bushing in a 95% alcohol solution, with dry ice solution. Leave the bushing in the solution long enough to reach the solution temperature, about -110°F (-80°C).

**CAUTION!:** DO NOT TOUCH COLD SURFACES WITHOUT PROPER INSULATION TO PREVENT INJURY. ALCOHOL IS FLAMMABLE AND SHOULD ONLY BE USED IN OPEN AIR OR A WELL VENTILATED BUILDING. AVOID SPARKS AND OPEN FLAME. AVOID ALCOHOL VAPORS WHICH MAY CAUSE INJURY TO THE TISSUES OF THE NOSE AND EYES. AVOID EYE AND SKIN CONTACT. USE NEOPRENE OR BUTYL GLOVES, MONO-GOGGLES OR FACE-MASK AND IMPERMEABLE APRON. IT CONTAINS METHYL ALCOHOL AND IS POISONOUS IF INGESTED. SEE MANUFACTURER'S MATERIAL SAFETY DATA SHEETS FOR MORE INFORMATION. DO NOT RETURN SOLUTION TO A CLOSED CONTAINER UNTIL IT HAS REACHED ROOM TEMPERATURE OR THE CONTAINER MAY EXPLODE.

**NOTE:** ABSOLUTE CLEANLINES IS REQUIRED OF BOTH THE BUSHING AND THE CONNECTING ROD TO PREVENT DIRT FROM ACCUMULATING BETWEEN THEM. ASSEMBLY MUST BE IMMEDIATE SO THAT THE BUSHING DOES NOT WARM-UP AND STICK BEFORE IT IS IN PLACE. IF STICKING A NEW BUSHING, REMOVE BY NOTCHING AS IN REMOVAL INSTRUCTIONS, AND START OVER WITH ANOTHER NEW BUSHING. DO NOT SEAT A STUCK BUSHING WITH A PRESS OR HAMMER.

- Position the connecting rod on the press table so that the chamfered edge of the rod bushing hole is on top. Install the bushing quickly while it is very cold. Be sure to locate the bushing oil hole at the connecting rod oil passage before pressing it in. The bushing has exterior and interior annular grooves in line with the oil hole. Should the bushing shift circumferentially during operation oil can still travel to its inner surface and to the cross-head pin. However, during installation of a new bushing, no more than 1/3 of the oil passage hole in the rod should be covered by the bushing.



**FIGURE 5-6 ROD BUSHING INSTALLATION**

## Connecting Rod - Installation

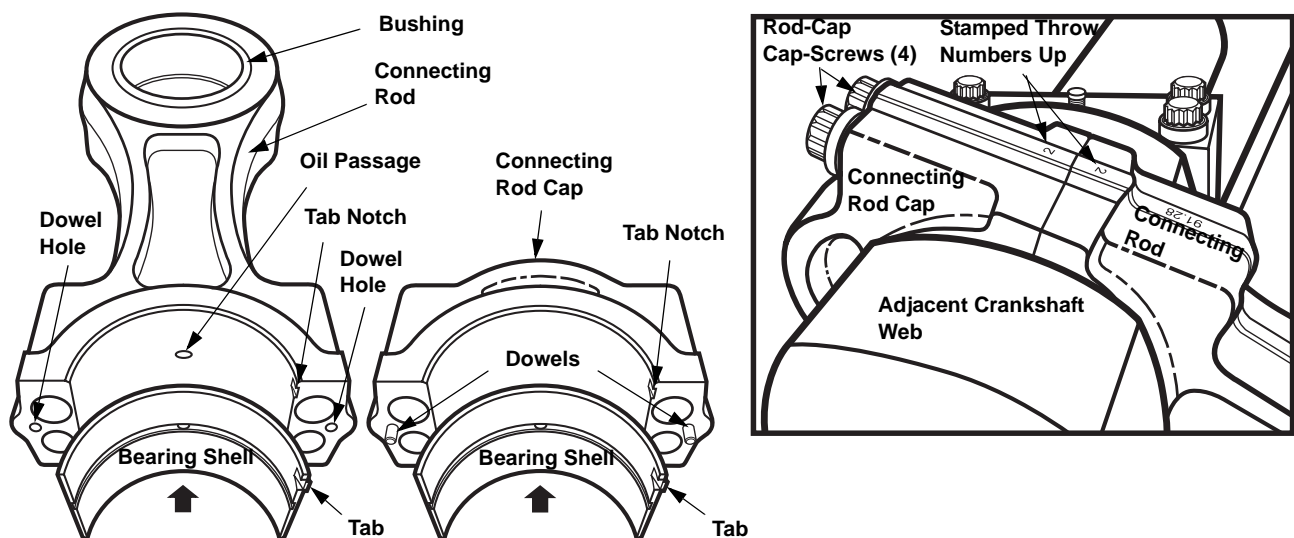
- If installing a new replacement connecting rod, stamp throw number on the tops of the connecting rod and bearing cap, (with bearing notches up), matching its throw location, see Figure 5-7 on Page 5-9.
- Check new bearing shells to see they are free of handling damage, scratches, burrs, and loose material at the tabs. **DO NOT RUB BEARING SURFACE WITH FINGERNAIL.** Check the part number on each connecting rod when ordering and installing bearings to be sure that the bearing part numbers being installed are compatible with the connecting rod.

**NOTE:** DO MIX BEARING SHELL PART NUMBERS ON AN INDIVIDUAL CONNECTING ROD. BOTH HALF SHELLS MUST HAVE THE SAME PART NUMBER.

- New bearing shells and crankshaft crank pin bearing surfaces must be abso-

lutely clean. Snap new dry half bearing shells into the rod and bearing cap with the bearing tabs properly located in the notches. With the crankcase top cover and crosshead guide covers off, turn the throw to near the inner dead center position. Apply new clean lubricating oil, same type as is used in the frame, liberally to rod bearing shell face. Slide the properly numbered rod matching the throw number, with bearing shell installed, into the crosshead guide space toward the crankshaft while supporting the rod.

**NOTE: THE CAPS AND RODS ARE NUMBERED BY THROW BEGINNING WITH NUMBER ONE AT THE DRIVE END. SEE FIGURE 1-1, FIGURE 1-2 AND FIGURE 1-3 FOR THROW NUMBERING SEQUENCE. ALWAYS INSTALL RODS AND CAPS WITH THE NUMBERS UP (OR TOWARD ACCESS OPENING IN THE JGI). BE SURE TO PROTECT CRANK PIN AT ALL TIMES.**



**FIGURE 5-7 CONNECTING ROD ASSEMBLY INSTALLATION**

4. Fit the rod to the crank pin and turn the crankshaft to position the crank pin up, near to the highest position, while supporting the rod. Oil the crankshaft crank pin bearing surfaces with new clean lubricating oil, same type as is used in the frame, before installing the connecting rod cap. Lubricate cap bolting threads and seating surfaces with a thin coating of oil. Insert cap-screws into the cap. Slide bolting out of the cap until ends of all bolts are even with the cap parting face. Use the top bolts as handles to move the cap into place. Place the properly numbered cap matching the throw number on to the top of the crank pin with the parting face parallel to the rod face, and with numbered matching number up (the tab side of the bearing toward the throw). Align the rod cap dowels with the rod dowel holes and push into the rod. Screw all cap bolting into the connecting rod and snug up. Do not tighten the bolting at this point.
5. Install the crosshead and attach to the connecting rod. See "Crosshead - Installation" on Page 5-13.
6. Tighten the connecting rod bolting an alternating (criss-cross) pattern in 25% increments for each cap to full torque, to the values listed in Table 1-12 on page 1-16.
7. Measure each crankshaft to connecting rod bearing jack clearance and connecting rod thrust (side) clearance. See "Connecting Rod (Crank Pin) Bearing" on Page 5-4. Record readings on the form on Page 5-48. Also check crosshead pin bushing clearance to Table 1-3 on page 1-10. If readings are not within tolerance



after installing new bearings, bushings, etc., contact your packager or Ariel before proceeding.

8. Examine the top cover or access cover gaskets. If there is any doubt about their condition, install new gaskets. Before installing a gasket, apply an antiseize lubricant to both sides or to the metal seating surfaces. This will help to hold the gasket in place during assembly and aid in easy of removal. Additional lubrication to provide for gasket release, is not required. Replace the top cover or access cover and crosshead guide covers. Tighten all cover cap screws hand wrench tight.

## Crosshead

### ⚠ CAUTION

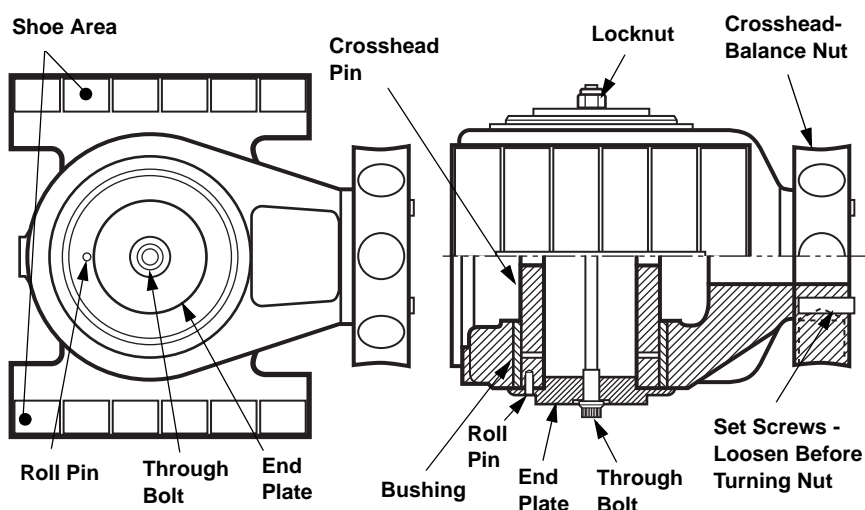
BEFORE REMOVING THE CYLINDER HEAD, BACK OFF ALL CAP SCREWS 1/8 INCH (3 mm). MAKE SURE THAT THE HEAD IS LOOSE AND THE CYLINDER IS VENTED. SEE IMPORTANT SAFETY INFORMATION PLATES ON COMPRESSOR TOP COVER, REFER TO TABLE 1-4 ON PAGE 1-6 FOR LOCATION.

### ⚠ CAUTION

CROSSHEADS ARE HEAVY. CARE MUST BE TAKEN WHEN HANDLING TO AVOID PERSONAL INJURY. THE WEIGHT OF EACH CROSSHEAD IS LISTED IN THE BALANCE SHEET THAT COMES IN THE MANUAL WITH EACH COMPRESSOR.

## Crosshead - Removal

1. Loosen all cylinder heads to the Caution note above to be sure cylinders are completely vented.
2. Remove crosshead guide side covers.
3. Remove the cylinder head (or VVCP). In the case of tandem cylinders where the outboard cylinder bore is

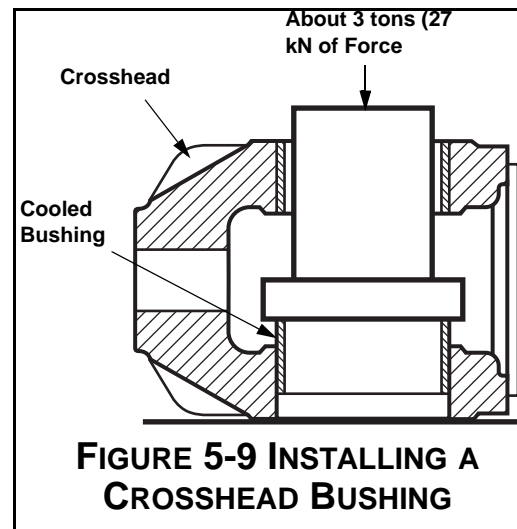


**FIGURE 5-8 CROSSHEAD - TYPICAL**

- smaller than the inboard bore, it is necessary to remove the outboard cylinder. Support such cylinders during removal and installation, as to not put excessive weight on the piston and rod assembly which might cause bending.
4. Turn the crankshaft to position the crosshead to near its inner dead center position and back off, but do not remove, the crosshead-balance nut set screws. Loosen the nut with the special slugging Peg or Open End Wrench shown in Figure 7-1 on page 7-2, depending on nut style.
5. Turn the crosshead-balance nut off the piston rod, while removing the piston and

rod assembly, see "Piston and Rod" on page 5-27.

6. Turn the crankshaft to position the crosshead near to its outer dead center position, remove the crosshead pin through bolt, lock nut, end-plates and pin. Crib JGI models so that crosshead does not fall down.
7. Turn the crankshaft to near the inner dead center position. Move the crosshead to its outer dead center position to be free of the connecting rod. Be sure the connecting rod does not drop and damage the crosshead guide surface.
8. Rotate the crosshead 90 degrees and remove it through the guide opening.
9. Check the crosshead pin to crosshead/bushing clearance, refer to Table 1-3 on page 1-10. Wear on the pin can be determined by a visual inspection.
10. Replace the pin if necessary. If the bushings need to be replaced, hacksaw or file to within 1/32 inches (1 mm) of their thickness, being careful not to cut into the crosshead. They can then be easily drifted out.
11. A press is required to install new bushings. Do not use a hammer to force a bushing into place as this will distort the bushing's bore. The new bushings are to be installed in the crosshead by cooling the bushings in a 95 percent alcohol with dry ice solution. The bushings need to be left in the solution long enough to reach the same temperature as the solution, about -110°F (-80°C). Position the crosshead on the press table so that the side receiving the new bushing is supported directly, see Figure. Quickly seat new bushings while they are still very cold.



**CAUTION!:** DO NOT TOUCH COLD SURFACES WITHOUT PROPER INSULATION TO PREVENT INJURY. ALCOHOL IS FLAMMABLE AND SHOULD ONLY BE USED IN OPEN AIR OR A WELL VENTILATED BUILDING. AVOID SPARKS AND OPEN FLAME. AVOID ALCOHOL VAPORS WHICH CAN CAUSE INJURY TO THE TISSUES OF THE NOSE AND EYES. AVOID EYE AND SKIN CONTACT. USE NEOPRENE OR BUTYL GLOVES, MONO-GOGGLES OR FACE-MASK AND IMPERMEABLE APRON. THE SOLUTION CONTAINS METHYL ALCOHOL AND IS POISONOUS IF INGESTED. SEE MANUFACTURER'S MATERIAL SAFETY DATA SHEETS FOR MORE INFORMATION. DO NOT RETURN SOLUTION TO A CLOSED CONTAINER UNTIL IT HAS REACHED ROOM TEMPERATURE OR THE CONTAINER MAY EXPLODE.

**NOTE:** ABSOLUTE CLEANLINESS IS REQUIRED OF BOTH THE CROSSHEAD AND THE BUSHINGS TO PREVENT DIRT FROM ACCUMULATING BETWEEN THE BUSHING AND CROSSHEAD BORE.

**NOTE:** THE SIDE OF THE CROSSHEAD RECEIVING THE NEW BUSHING SHOULD BE SUPPORTED DIRECTLY TO PREVENT POSSIBLE CRUSHING OF THE CROSSHEAD BY THE PRESS, SEE FIGURE 5-9 ON PAGE 1-12.

12. Visually inspect the shoe surfaces for scoring. Since they are constantly lubricated under pressure during operation, there should be virtually no wear.

## Crosshead - Installation

**NOTE: BE SURE CROSSHEADS ARE RETURNED TO THEIR ORIGINAL THROW LOCATION.**

1. With the throw positioned near to its inner dead center position, turn the crosshead on its side and slip it into the crosshead guide. Rotate the crosshead 90° into place. Make sure it does not become cocked. Should the crosshead become wedged, do not force it. Ease it off and start again. Be careful not to damage the crosshead shoe surface during installation.
2. Lift the crosshead end of the connecting rod and turn the crankshaft to near the outer dead center position to locate the connecting rod in the crosshead. Align connecting rod bushing with the crosshead bushings and insert the crosshead pin.
3. Install the end plates, through bolt and locknut. Tighten the locknut to the torque value listed in Table 1-12 on page 1-16.
4. Be sure that the crosshead-balance nut seating surfaces are flat and free of burrs. Dress with a flat stone as required. The piston rod threads are to be lubricated with a thin coat of Never Seez, regular grade, and the crosshead-balance nut seating surfaces with new oil (same grade as used in the frame).
5. Re-install the crosshead-balance nut on the piston rod. Be sure to have set-screw cup points on the crosshead side of the nut. Install the piston and rod assembly in the cylinder. See "Piston and Rod - Installation" on page 5-30.

**NOTE: PISTON END CLEARANCE MUST NOW BE SET OR SERIOUS DAMAGE COULD OCCUR. SEE THE REQUIRED PISTON CRANK END CLEARANCE AS SHOWN ON THE CYLINDER IDENTIFICATION PLATE, REFER TO TABLE 1-3 ON PAGE 1-10.**

6. Position the crankshaft to the exact inner dead center position of the throw.

**NOTE: UTILIZE A DIAL INDICATOR WITH A MAGNETIC BASE TO INDICATE THE LOCATION OF THE CROSSHEAD WHEN FINDING EXACT INNER DEAD CENTER POSITION.**

7. Determine the required piston crank end clearance from the cylinder identification plate, refer to Table 1-3 on page 1-10. Insert a feeler gage, equal to the required crank end clearance, through an open valve pocket. For 13 in. (330 mm) and larger cylinders, insert the feeler gage through a bottom valve pocket. For 2-3/4M, 3M, 2-3/4P-CE and 3-1/4P-CE class cylinders, use the Ariel furnished clearance setting tool A-13801 as a feeler gage, see Figure 7-1 on page 7-2 (this tool must be inserted horizontally with end notch side toward the crank end and rotated 90° to position the end notch up, prior to performing step 6. above). 2-1/4P-CE class cylinders use clearance setting tool A-11344. Screw the piston rod into the crosshead until piston is tight against the feeler gage, so that the feeler gage can not be removed by hand.
8. Use the Ariel furnished special slugging peg or open end wrench shown in Figure 7-1 on page 7-2 and a dead blow semi-soft faced hammer to tighten the crosshead-balance nut by the tried and true slugging method. Strike the wrench with the hammer until an audible difference can be heard, and/or on seeing the wrench "bounce" indicating that the nut is tight. Some mechanics can obtain the desired tightness in 3 to 4 strikes, while others may require more hammer blows.
9. When the nut is tight, the feeler gage can be removed by hand.

10. Be sure all tools are removed and install the cylinder head (or unloader) and tighten fasteners to Table 1-12 on page 1-16.
11. With the cylinder head or unloader (closed position) properly installed, rotate the crankshaft to the exact outer dead center position of the throw.

**NOTE: UTILIZE A DIAL INDICATOR WITH A MAGNETIC BASE TO INDICATE THE LOCATION OF THE CROSSHEAD WHEN FINDING EXACT OUTER DEAD CENTER POSITION.**

12. Remove a top head end valve.
13. Determine the required piston head end clearance limits from the cylinder identification plate, refer to Figure 1-4 on page 1-6. Measure head end clearance at the top of the head end. Using feeler gages through the open valve pocket, check the head end clearance. Determine that the measured clearance is within the required clearance limits. If clearance is out of limits, contact your packager or Ariel.
14. Remove dial indicator and base.
15. Tighten the set screws in the crosshead-balance nut.
16. Install the valve assemblies and properly tighten fasteners, refer to "Valves - Reassembly" on page 5-41 and "Bolt Tightening for Valve Caps" on page 5-42.
17. Check piston rod run out and crosshead clearances upon re-assembly, any time a piston rod is removed, see "Piston Rod Run Out" on page 5-31, and Table 1-3 on page 1-10 for crosshead clearances and checking procedure. If clearances are out of limits, contact your packager or Ariel.
18. Replace the crosshead guide side covers and gaskets, tighten all cover cap screws hand wrench tight. Before installing a gasket, apply an antiseize lubricant to both sides or to the metal seating surfaces. This will help to hold the gasket in place during assembly and aid in easy of removal.

## Crankshaft

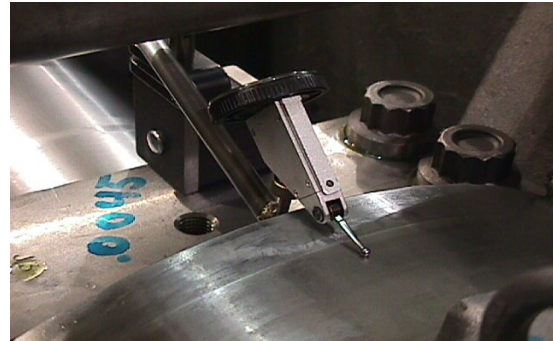
### Main Bearings - Checking Clearances

1. Do not remove main bearing caps to check for bearing wear, if a cap is removed it is recommended that a new bearing be installed, i.e. **DO NOT REUSE BEARING SHELLS.**
2. Determine main bearing wear by checking actual journal bearing vertical jack, at each bearing, and crankshaft thrust clearances against the clearance limits given in Table 1-3 on page 1-10, and last new bearing clearance values if available. High copper content in the oil analysis may be an indication of bearing wear. Use calibrated dial indicators with 0.0005 inch (0.005 mm) increments and magnetic stands to check clearances. Measure main bearing vertical jack clearances:
  - a. As shown in Figure 5-10 on Page 5-15, turn an adjacent throw up to the highest position.
  - b. Place lifting strap completely around the crankshaft at the adjacent web and attach strap to a crane or a long pry bar.
  - c. Install a magnetic stand on the top of the main bearing cap, with a needle type dial indicator placed against the top of the crankshaft web of the adja-

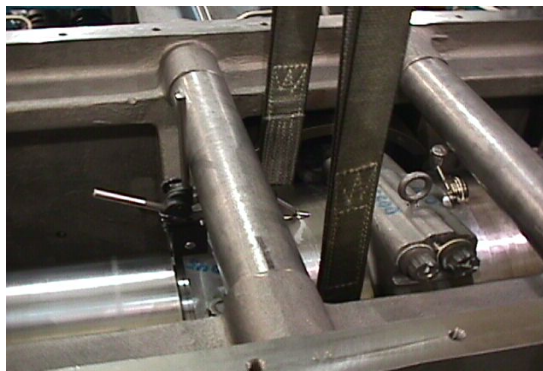
- cent turned up throw. Push down and set indicator to zero.
- d. Gently lift crankshaft with the strap until the needle on dial indicator stops moving, repeat to be sure the reading is accurate. This is best done before the connecting rods are installed by putting a clean lifting strap around the adjacent pin and pulling up on the crankshaft with the strap.
  - e. Repeat Paragraphs a. through d. for each main bearing.



Dial Indicator Magnetic Stand Placement  
on Top of the Main Bearing Cap



Needle Type Dial Indicator Placement  
on Top of Crankshaft Web



Lifting Strap Placement, Completely around Crankshaft Web - Attach Lifting Straps to Crane

### FIGURE 5-10 MEASURING CRANKSHAFT JOURNAL BEARING VERTICAL JACK CLEARANCE - TYPICAL

3. Measure the crankshaft thrust clearance as follows:
  - a. As shown in Figure 5-11 on Page 5-16, install a magnetic stand on the top of #1 main bearing cap, with a button type dial indicator placed against the side of the adjacent crankshaft web.
  - b. Use an appropriate pry bar against the compressor frame and thrust the crankshaft tight toward the dial indicator. Release pressure on the pry bar. Hold crankshaft in place with minimum pressure to keep it from moving. Set the dial indicator to zero. Then pry on the crankshaft to thrust in the opposite direction tight and release pressure. Hold the crankshaft in place with minimum pressure to keep it from moving to determine thrust clearance. Repeat to be sure the reading is accurate. Note that crankshaft thrust clearance can also be checked externally with the coupling disconnected and without removing the top covers.
  - c. If thrust clearance is out of limits, replace thrust plates at #1 main bearing

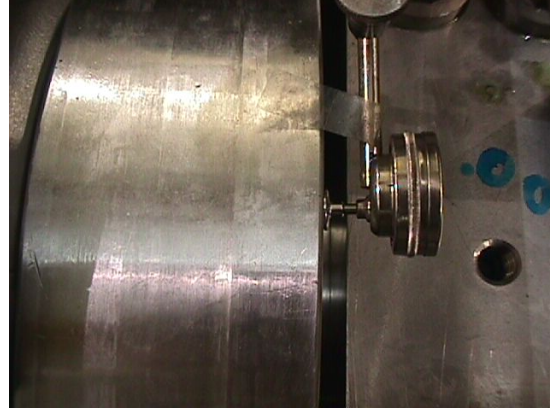


cap.

4. After installing new bearings, check jack and thrust clearances against the clearance limits. If clearances are out of limits, contact your packager or Ariel. Record values on a copy of the form on Page 5-48.



Dial Indicator Magnetic Stand Placement on Top of Main Bearing Cap



Button Type Dial Indicator Placement against the side of Crankshaft Web

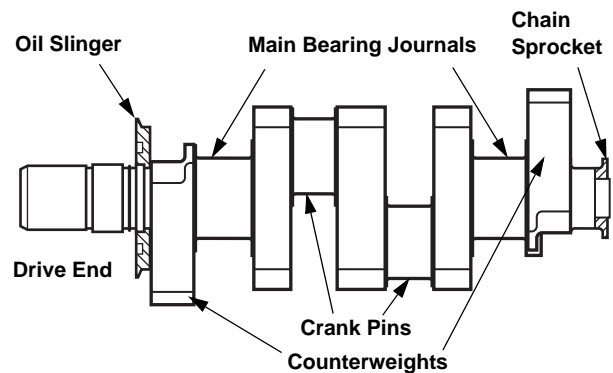


Use a Pry Bar against Compressor Frame, Thrusting Crankshaft Back & Forth

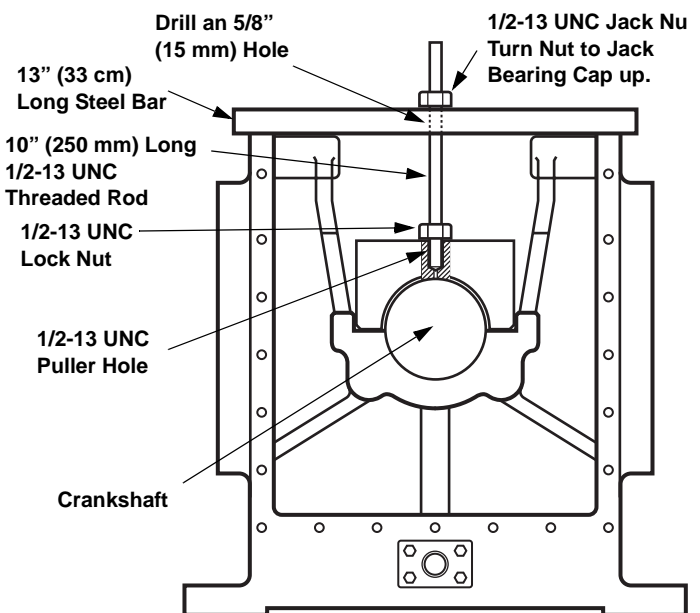
### FIGURE 5-11 MEASURING CRANKSHAFT THRUST CLEARANCE

## Crankshaft - Removal

1. Drain oil from crankcase.
2. Remove the coupling. Remove the coupling adapter.
3. Remove the top cover and crankshaft seal housing (or connecting rod, chain drive and crosshead access covers for a JGI).
4. Detach the connecting rods. (See "Connecting Rod - Removal" on page 5-6.) Move the rods to their full outer position. For the JGI, cribbing at the crosshead guide access hole is required to keep connecting rod up at the full outer position.
5. Remove the cap screws on the chain adjustment cap. Turn the cap to loosen the chain. Slip the chain off the crankshaft sprocket. Remove the force feed lubricator.
6. Remove the cap screws from the main bearing caps. Pull the caps straight up to prevent damage to the dowel fit. If the cap is tight, use a Bearing Cap Puller as illustrated in the Figure. For the JGI remove the cap screws in the bearing carrier, remove carrier and slide crankshaft out through carrier hole to remove it.
7. Before removing the crankshaft from the crankcase, wooden saddles or a notched wooden crate with sides high enough to prevent the webs or oil slinger from touching bottom should be prepared in order to store the crankshaft during maintenance - even though it may be out for only a short time. In addition, the crankshaft should be adequately protected from above so that dropped tools or equipment cannot mar the surface of pins and journals.
8. For horizontally opposed models, turn the crankshaft so that the drive end counterweight is straight up. The two throw crankshaft weighs about 100 lb (45 kg) and can be lifted out by two persons or by using a crane and a clean nylon lifting sling at the second throw crank pin. The sling lifting point is to be above the center of gravity of the shaft, so that it does not want to rotate when lifted. Lift the crankshaft to tip up the chain drive end so that the crankshaft drive end will clear the frame seal housing opening and allow removal. Great care must be taken



**FIGURE 5-12 CRANKSHAFT WITH OIL SLINGER & SPROCKET**



**FIGURE 5-13 BEARING CAP PULLER**



during this operation since the shaft could bind and become damaged. Wear gloves to avoid being cut by the slinger and to achieve a good grip. (As with each operation, the gloves should be clean to avoid marring of the running surface.)

**NOTE: THE LOWER HALF BEARING SHELLS SOMETIMES HAVE A TENDENCY TO STICK TO THE SHAFT JOURNALS BECAUSE OF THE CLOSE FITTING OILY SURFACES OF THE TWO PARTS. THEREFORE, WHEN THE SHAFT HAS BEEN LIFTED CLEAR OF THE SADDLES, APPROXIMATELY 1/4 INCH (6 mm), CHECK TO MAKE SURE THAT THE LOWER HALF BEARING SHELLS HAVE NOT COME OUT WITH THE SHAFT. IF SO, THE BEARING SHELLS SHOULD BE TAPPED BACK ONTO THE SADDLES BEFORE LIFTING THE SHAFT ANY FURTHER.**

## Oil Slinger - Removal

Although the slinger should last indefinitely with proper care, it can become nicked. Should it need replacement, suspend the crankshaft on a sling with the auxiliary end up, and heat the slinger to 400° F (240°C). It will attain a yellow glow at this temperature. When it has expanded it should fall off by itself. Do not over heat.

**CAUTION!: DO NOT TOUCH HOT SURFACES WITHOUT PROPER INSULATION TO PREVENT INJURY.**

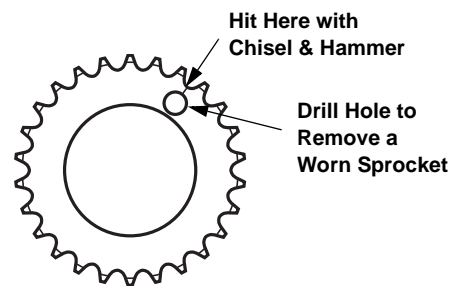
## Oil Slinger - Installation

Put the crankshaft in the horizontal position. Put a rod of at least 1/2 inches (13 mm) in diameter through the slinger. (Special care should be exercised when handling the slinger, not only to keep its surfaces unmarred, but to avoid being cut by the outer sharp edge.) With the slinger suspended from the rod, heat it with a small torch. When it has attained a yellow glow, approximately 400°F (240°C), it can be slipped over the drive end of the crankshaft. Do not over heat the oil slinger. Be sure it is properly oriented before installing. Hold the slinger in position with high temperature gloves or two pieces of clean wood, rotating it slightly to make sure it is square and tight against the shoulder, until it has cooled enough to shrink onto the crankshaft.

**CAUTION!: DO NOT TOUCH HOT SURFACES WITHOUT PROPER INSULATION TO PREVENT INJURY.**

## Chain Sprocket - Removal

1. Examine the sprocket carefully for signs of wear. If it has been in operation for five years or more, it may be convenient to replace it if the crankshaft is removed from the frame.
2. Drill a hole in the sprocket hub. This hole should be parallel to the shaft centerline and big enough that it removes most of the hub cross section, see Figure. Be careful not to touch the shaft with the drill. Mark the drill with tape so you do not drill



**FIGURE 5-14 CRANKSHAFT CHAIN SPROCKET - TYPICAL**

through the sprocket and into the crankshaft face.

3. The drilled hole will relieve most of the shrink, and a couple of good radial hits with a hammer and chisel will open the sprocket enough so it can be easily removed.

## Chain Sprocket - Installation

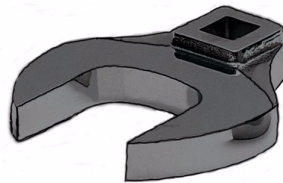
Encircle the sprocket with wire. Suspend the sprocket from the wire and heat it with a small propane torch. When it has attained a yellow glow, approximately 400°F (240°C), it can be slipped over the auxiliary end of the crankshaft. Do not over heat the sprocket. Hold the sprocket in position with high temperature gloves or two pieces of clean wood, rotating it slightly to make sure it is square, until it has cooled enough to shrink on the crankshaft.

**CAUTION!: DO NOT TOUCH HOT SURFACES WITHOUT PROPER INSULATION TO PREVENT INJURY.**

## Fan Shaft Assembly Procedure

For JG:A/2/4 and JGM:N:P:Q/2 compressors with a fan shaft, install on the crankshaft:

1. Use Loctite primer "T" and apply Loctite 620 (Green) Retaining Compound to the stud threads, on one end only.
2. Work quickly before Loctite begins to harden and thread the stud end with the Loctite into the fan shaft until fully seated, hand tight, in the bottom of the hole. Do not torque the stud in the fan shaft.
3. Do not apply Loctite to the crankshaft end of the stud.
4. Lubricate the crankshaft end stud threads and the fan shaft shoulder seating surfaces with oil.
5. Thread the stud into the crankshaft and snug up the fan shaft.
6. **Use a calibrated torque wrench with an open end 1-5/8 in. crowfoot, such as "Snap-On" SCO52 (1/2 in. drive) or equal positioned at a right angle, on the wrench flats to tighten the fan shaft.** If the crowfoot is not at a right angle to the torque wrench, adjust the torque wrench reading to provide the desired torque value on the fan shaft. Refer to the Ariel Technical Manual, Section 1, for tightening procedures.



**FIGURE 5-15 OPEN END CROWFOOT WRENCH**

7. Tighten the fan shaft to the torque value in Table 1-12 on page 1-16. Loosen the fan shaft to hand tight. Repeat the tightening torque and loosening before the final tightening torque to Table 1-12 on page 1-16, (for a total of three tightenings).
8. Check the fan shaft runout at the keyway. Runout should be less than 0.010 in.

(0.25 mm) TIR.

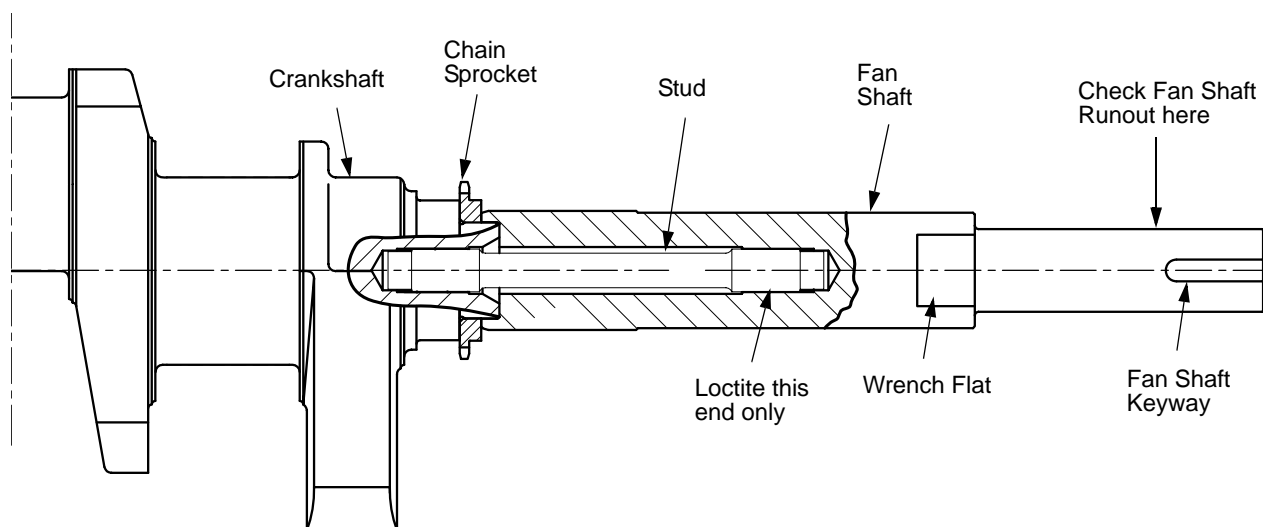


FIGURE 5-16 FAN SHAFT

## Main Bearings - Removal and Installation w/Crankshaft Removed

Do not remove a main bearing cap to check for bearing wear, if cap is removed it is recommended that a new bearing is installed, i.e. **DO NOT REUSE BEARING SHELLS**. Determine bearing wear by checking actual jack and crankshaft thrust clearances against the clearance limits given in Table 1-3 on page 1-10. See "Main Bearings - Checking Clearances" on Page 5-14. High copper content in the oil analysis may be an indication of main and/or connecting rod bearing wear, and/or chain idler, crosshead, connecting rod bushings wear (excessive use of anti-seize lubricates can also elevate copper content in the oil analysis).

There are notches in the frame and bearing cap for the bearing tabs in order to position and maintain the position of the bearing halves. Check the new bearing shells for handling damage, scratches, burrs, and loose material at the tab. **DO NOT RUB BEARING SURFACE WITH FINGERNAIL**. The bearing shells must be absolutely clean. Be sure that bearing shell part numbers on both halves match.

The old bearings halves are easily slid out, tab end first. Be sure both the main bearing saddles and crankshaft are absolutely clean, and free from nicks and burrs. New bearings are to be slid in (untabbed end first), and snapped into place. Locate tabs in the notches in the bearing saddles and bearing caps.

On JGI models, remove the carrier bearing using a hydraulic press or jack. Remove the frame bearing using a hydraulic jack. A pushing tool with a shoulder is needed. Install new bearings by cooling the bushings and using the hydraulic tools. Do not use a hammer to force the bushings into place as this will distort the bearing's bore. The new bushings are to be installed into the connecting rod by cooling the bushing in a 95 percent alcohol solution with dry ice solution. The bushing needs to be left in the solution long enough to reach the same temperature as the solution, about -110°F (-80°C). Oil holes on bearing must be aligned with holes in frame and carrier. The bushings must be pressed 3/16 in. (4.8 mm)

below flush of the thrust faces, no more than 1/3 of the oil passage hole in the rod can be covered by the bushing.

**CAUTION!: DO NOT TOUCH COLD SURFACES WITHOUT PROPER INSULATION TO PREVENT INJURY. ALCOHOL IS FLAMMABLE AND SHOULD ONLY BE USED IN OPEN AIR OR A WELL VENTILATED BUILDING. AVOID SPARKS AND OPEN FLAME. AVOID ALCOHOL VAPORS WHICH MAY CAUSE INJURY TO THE TISSUES OF THE NOSE AND EYES. AVOID EYE AND SKIN CONTACT. USE NEOPRENE OR BUTYL GLOVES, MONO-GOGGLES OR FACE-MASK AND IMPERMEABLE APRON. IT CONTAINS METHYL ALCOHOL AND IS POISONOUS IF INGESTED. SEE MANUFACTURER'S MATERIAL SAFETY DATA SHEETS FOR MORE INFORMATION. DO NOT RETURN SOLUTION TO A CLOSED CONTAINER UNTIL IT HAS REACHED ROOM TEMPERATURE OR THE CONTAINER MAY EXPLODE.**

**NOTE: ABSOLUTE CLEANLINESS IS REQUIRED. ASSEMBLY MUST BE IMMEDIATE SO THAT THE BEARING DOES NOT WARM-UP AND STICK BEFORE IT IS IN PLACE. DO NOT SEAT A STUCK BUSHING WITH A PRESS OR HAMMER.**

## **Main Bearings - Removal and Installation w/Crankshaft In Place**

**NOTE: REPLACE ONE MAIN BEARING AT A TIME. REMOVE THE CAP ON THE BEARING BRING CHANGED, CHANGE THAT BEARING AND REPLACE THE CAP AND TIGHTEN THE BOLTING PRIOR TO STARTING THE NEXT BEARING.**

1. Follow instructions in "CAUTION" on Page 5-2. Remove coupling spacer or otherwise lockout.
2. Remove the top cover.
3. Remove the cap screws from main (journal) bearing cap #1. Pull the cap straight up to prevent damage to the dowel fit. If the cap is tight, use a Bearing Cap Puller as illustrated in Figure 5-13 on Page 5-17.
4. If necessary, attach clean nylon lifting straps around the crankshaft and lift slightly to take some of the weight off the bearings and allow for easier disassembly of a bearing shell.
5. Remove the shell from the main bearing cap. Remove the main journal bearing shell from under the crankshaft, by rotating out. Start rotating the shell under the crankshaft tab side out first, by pushing or tapping with a non-metallic tool on the opposite split face side. Once the bearing shell is completely loose, use purchased separately Main Bearing Pusher Removal Tool (part number G-10706 or may be made from prints supplied by Ariel) to push out bearing shells, see Figure 7-2 on page 7-3. Once started the shell may be rotated out, by releasing the lifting straps and turning the crankshaft. Be careful not to damage the crankshaft bearing surfaces.
6. Clean and dry main bearing cap to bearing surfaces.
7. Check the new bearing shells for handling damage, scratches, burrs, and loose material at the tab. **DO NOT RUB BEARING SURFACE WITH FINGERNAIL.** The bearing shells must be absolutely clean. Install new bearing shells in cap, and frame journal, properly located in the tab notch, (rotate in the untabbed end first), keeping the backs of the shells dry and clean.

**NOTE: DO MIX BEARING SHELL PART NUMBERS ON AN INDIVIDUAL MAIN OR CONNECTING ROD. BOTH HALF SHELLS MUST HAVE THE SAME PART NUMBER.**

8. Oil crankshaft bearing surfaces with new clean lubricating oil, same type as is used in the frame, before installing the main bearing cap.
9. Replace thrust plates on bearing cap #1, if crankshaft thrust clearance is not within tolerance.
10. Install the bearing cap, containing a new half bearing shell. Be sure the dowels in the bearing caps are aligned with the holes in the crankcase base. A set screw on top of each dowel prevents it from backing out. Install the cap screws and tighten them in an alternating (criss-cross) pattern to the torque value given in Table 1-12 on page 1-16.
11. Repeat one throw at a time for each bearing until all main bearings are replaced.
12. Check crankshaft journal bearing jack (at each bearing) and crankshaft thrust clearances to values in Table 1-3 on page 1-10. See "Main Bearings - Checking Clearances" on Page 5-14. Record readings on a copy of form on Page 5-48.
13. If readings are not within tolerance after installing new bearings, contact your packager or Ariel before proceeding.
14. Account for all tools, measuring and lifting equipment, supplies, replaced parts, etc. to be sure they have all been removed from inside the crankcase and then re-install the gaskets and top cover. Before installing a gasket, apply an anti-seize lubricant to both sides or to the metal seating surfaces. This will help to hold the gasket in place during assembly and aid in easy of removal. Tighten cover bolts hand wrench tight.
15. Replace coupling spacer to packager's recommendations or remove lockout.
16. After replacing bearings, thoroughly pre-lube compressor to be sure that bearings are lubricated and to help remove foreign materials from the lube system.
17. When starting the compressor after the first 10 minutes of run time, after one hour, and after four hours, shutdown compressor and remove the frame top cover. Check the bearing cap temperatures using a temperature probe (hand held thermocouple probe or infrared thermometer), record on a copy of form on Page 5-48. **DO NOT PLACE ANY PART OF YOUR BODY INSIDE THE CRANKCASE WITHOUT OBSERVING THE "CAUTION" ON PAGE 5-2.** Complete remaining information on the "Bearing Log / Conditions After Replacing Bearings" form and fax copy to Ariel Technical Services. Keep a copy with the compressor records.

## Crankshaft - Installation

1. Put new bearing shells in place on the saddles in the frame and in the bearing caps to "Main Bearings - Removal and Installation w/Crankshaft Removed" on Page 5-20. Move the connecting rods to their full outer position. Oil crankshaft bearing surfaces with new clean lubricating oil, same type as is used in the frame, before installing. While the crankshaft is being lowered very slowly into the crankcase (if suspended by a crane with a nylon sling, use second throw crank pin), maneuver the drive end into the crankcase to clear the seal housing opening. Use clean gloves as during removal. Lower crankshaft into place so that both drive end and auxiliary end journals touch the bearing saddles at the

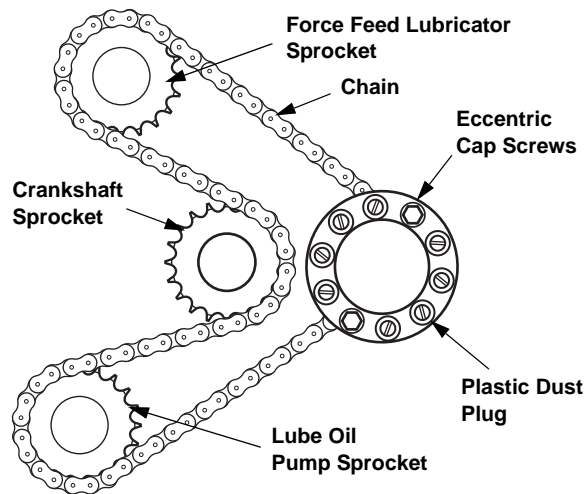
- same time. (For JGI models, slide crankshaft into position through the bearing carrier opening and then replace bearing carrier).
2. When the crankshaft is resting on the bearing saddles, install all bearing caps with their new bearing half shells. Bearing caps are match-marked to correspond with the throw position on the frame, be sure they are in the proper locations. Lubricate the bearing cap bolting threads and seating surfaces with oil and instal lightly snugged.
  3. Be sure the dowels in the bearing caps are aligned with the holes in the crankcase base. A set screw on top of each dowel prevents it from backing out.
  4. Then, starting at the thrust end, tighten the bolts in an alternating (criss-cross) pattern in 25% increments to the recommended torque value in Table 1-12 on page 1-16.
  5. Check crankshaft journal bearing jack (at each bearing) and crankshaft thrust clearances to values in Table 1-3 on page 1-10. See "Main Bearings - Checking Clearances" on Page 5-14. Record readings on a copy of the form on Page 5-48.
  6. Replace connecting rods bearings and re-attach the connecting rods refer to "Connecting Rod - Installation" on page 1-8). Re-install the packing diaphragms, piston and rod, and unloaders/head end heads, if removed.
  7. Re-install the force feed lubricator and chain drive. (See "Chain Drive System" on page 5-23).
  8. Examine the top cover gasket. If there is any doubt that it is not in good usable condition, install a new gasket. Before installing a gasket, apply an antiseize lubricant to both sides or to the metal seating surfaces. This will help to hold the gasket in place during assembly and aid in easy of removal.
  9. Re-install covers, crankshaft seal housing and the top cover. Tighten cap screws hand wrench tight. Align crankshaft dust seal to clearance requirements in Table 1-3 on page 1-10.

## Chain Drive System

### Description

The chain drive system is crankshaft-driven at the auxiliary end of the frame. The chain runs the lube oil pump and force feed lubricator. Chain tightness is controlled by an idler sprocket attached to the eccentric adjustment cap. The chain dips into the crankcase oil and, as a

result, is constantly lubricated. See Figure for the auxiliary end components and chain drive system.



**FIGURE 5-17 CHAIN DRIVE SYSTEM - TYPICAL**

## Chain Adjustment

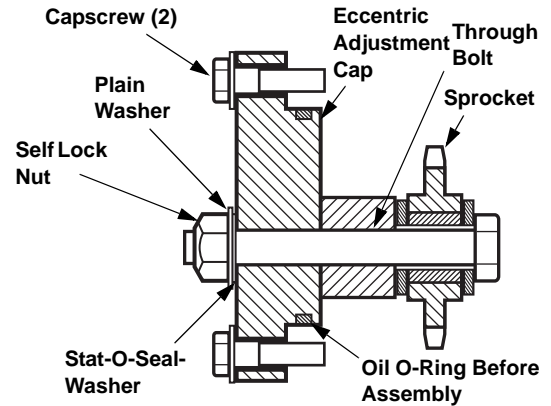
For proper chain adjustment procedures, see engineering reference ER-74 on the Ariel web-site at [www.arielcorp.com](http://www.arielcorp.com), or contact the Ariel Response Center.

## Chain and Sprocket Replacement

The chain should be replaced if the elongation exceeds 0.084 inches (2.13 mm) over a 10 pitch length. The section of chain to be measured should be stretched tight, in place, in the compressor and measured with vernier calipers. A reading made outside of the rollers at 10 pitches should be added to a reading between the inside of the same rollers and then be divided by two. If this calculation exceeds 3.834 inches (97.38 mm) for 3/8 pitch, the chain should be replaced. Any sprocket showing any undercutting should be replaced.

## Chain Idler Sprocket Replacement - (Eccentric Adjustment Cap)

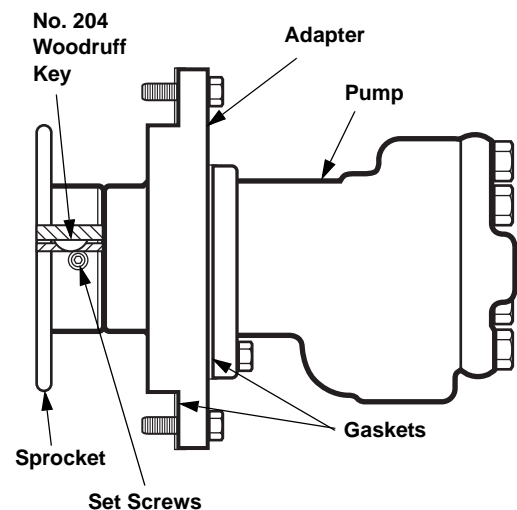
1. Remove the frame top cover (or chain access cover for JGI). Remove the two cap screws that hold the eccentric adjustment cap to the end cover. Rotate the eccentric cap to loosen the chain. After dropping the chain off the idler sprocket, the entire assembly can be removed from the frame.
2. Remove the lock nut, cap screw, sprocket, Stat-O-Seal washer and the cap O-ring. Discard these items since they must be replaced with new parts.
3. Reassemble all parts using a new cap screw, Stat-O-Seal washer, sprocket, and lock nut. Tighten the idler lock nut to the recommended torque given in Table 1-12 on page 1-16.
4. Apply oil to and install a new O-ring on the eccentric adjustment cap.
5. Install the assembly and adjust the chain according to the instructions given in "Chain Adjustment" on page 5-24.



**FIGURE 5-18 CHAIN IDLER SPROCKET (ECCENTRIC)**

## Lube Oil Pump Chain Sprocket Replacement

1. Remove the cap screws from the drive chain eccentric adjustment cap and rotate cap to loosen the chain. Remove all piping (tubing) from the pump. Remove fasteners from pump mounting adaptor, and the pump with sprocket will come free through the hole in the end cover after the removing the chain from the pump sprocket.
2. With a good machinist rule, measure the distance from the sprocket drive face to the pump mounting adaptor face to the nearest 0.01 inch or 1/64 inch or 0.5 mm, to provide for positioning the new sprocket. Record this measurement for reference.
3. With the oil pump on a bench, use an Allen Wrench to remove the sprocket set screw. Then, pull the sprocket from the pump shaft.
4. Remove the No. 204 Woodruff key.
5. If the pump is to be separated from the adapter, such as when replacing the pump, re-assemble using a new gasket. Before installing a gasket, apply an antiseize lubricant to both sides or to the metal seating surfaces. This will help to hold the gasket in place during assembly and aid in easy of removal.
6. Install a new No. 204 Woodruff key, after checking to be sure that it will fit into



**FIGURE 5-19 LUBE OIL PUMP AND SPROCKET**



- the new sprocket and shaft key-slots. If the key is too thick, it can be polished with emery cloth on a flat surface until it will slide into the slots for a snug fit. If the key is too high, file of the top edge for a snug fit.
7. Install the new sprocket to the original measurement between the sprocket drive face and the pump adapter flange face. When it is in the proper position, tighten the set screw. If the original measurement is not available, position sprocket as close as reasonably possible to the running position.
  8. Install a new gasket. Before installing a gasket, apply an antiseize lubricant to both sides or to the metal seating surfaces. This will help to hold the gasket in place during assembly and aid in easy of removal.
  9. Re-install the pump onto the frame and tighten the cap screws. Check the alignment to crankshaft drive sprocket, with crankshaft centered in end play, using a good straight edge and a good machinist rule to within 1/32 inch (1 mm). If not in alignment, loosen the set screw and adjust the sprocket position as necessary. Retighten the set screw when the sprocket is properly aligned.
  10. Re-install and adjust the chain according to the instructions in "Chain Adjustment" on page 5-24.
  11. Re-install all piping (tubing) to the pump.

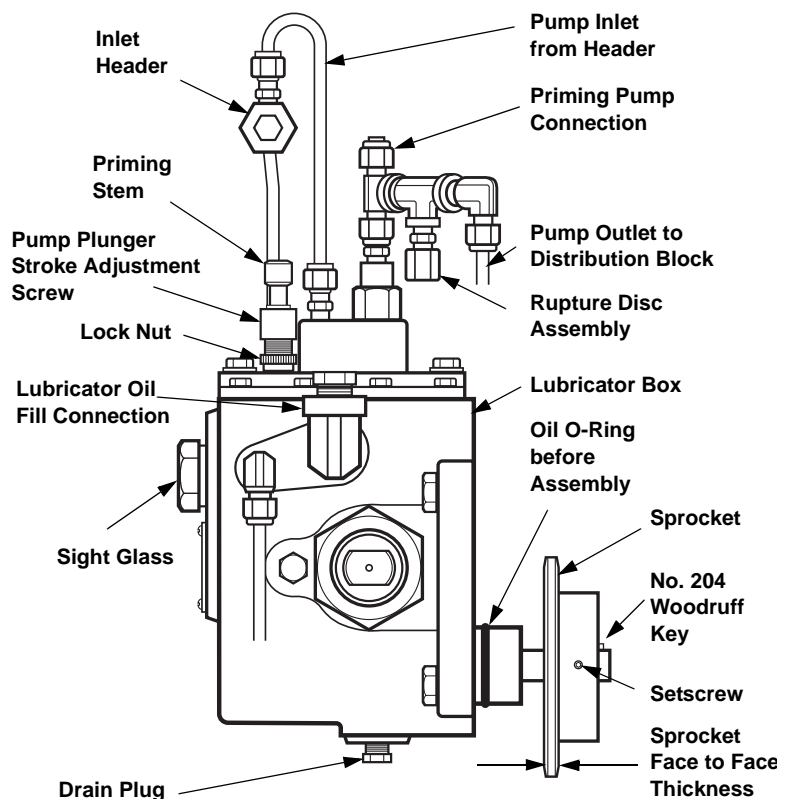
## Force Feed Lubricator Chain Sprocket Replacement

1. Remove the cap screws from the drive chain eccentric adjustment cap and rotate cap to loosen the chain.
2. Refer to the Figure.
3. After removing the chain from the lube sprocket, remove the sprocket set screw and sprocket. Detach all tubing to the lubricator.

4. Remove the four mounting bracket cap screws and remove the lubricator.

5. With the lubricator on the bench, remove the Woodruff Key from the shaft and file the shaft to remove any burrs raised by the cup point of the set screw. Install a new O-ring.

6. Install a new No. 204 Woodruff Key after first checking to make sure the key will fit into the new sprocket. If it is too thick, it can be polished with an emery cloth on



**FIGURE 5-20 FORCE FEED LUBRICATOR  
CHAIN SPROCKET - TYPICAL**

a flat surface until it can easily slide into the slots for a snug fit. If the key is too high, file of the top edge for a snug fit.

7. After the new key has been installed and it has been determined that the new sprocket will fit, oil the new O-ring and remount the lubricator on the frame.
8. Put the new sprocket onto the shaft.
9. Check alignment to the crankshaft drive sprocket with crankshaft centered in end play, using a straight edge, to within 1/32 inch (1 mm). Tighten the set screw.
10. Install chain and adjust using the instructions given in "Chain Adjustment" on page 5-24.
11. Re-attach all tubing to the lubricator.

## Piston and Rod

**NOTE: UTILIZE A DIAL INDICATOR WITH A MAGNETIC BASE TO INDICATE THE LOCATION OF THE CROSSHEAD WHEN FINDING EXACT INNER AND OUTER DEAD CENTER LOCATIONS.**

## Piston and Rod - Removal

### CAUTION

**TO PREVENT PERSONAL INJURY, BE SURE THAT COMPRESSOR CRANKSHAFT CANNOT BE TURNED BY THE DRIVER OR COMPRESSOR CYLINDER GAS PRESSURE DURING MAINTENANCE:**

- ON ENGINE-DRIVEN COMPRESSORS, REMOVE THE CENTER COUPLING OR LOCK THE FLYWHEEL.
- ON ELECTRIC MOTOR-DRIVEN COMPRESSORS, IF IT IS INCONVENIENT TO DETACH THE DRIVER FROM THE COMPRESSOR, THE DRIVER SWITCH GEAR MUST BE LOCKED OUT DURING MAINTENANCE.

**BEFORE PERFORMING ANY MAINTENANCE, COMPLETELY VENT SYSTEM. BEFORE REMOVING A CYLINDER HEAD OR VVCP, BACK OFF ALL CAP SCREW 1/8 INCH (3 mm). MAKE SURE THE HEAD IS LOOSE AND THE CYLINDER OR VVCP IS COMPLETELY VENTED.**

1. Follow steps 1. through 5. at "Crosshead - Removal" on page 5-11.
2. With the cylinder head/unloader removed and the cross-head balance nut loosened, use the piston turning/piston nut torquing tool (Ariel furnished tool) and a speed wrench to screw the piston and rod assembly out of the crosshead. The two dowels on the piston nut tool fit the holes in the piston nut. Turn the cross-head nut off the piston rod.
3. As the piston leaves the cylinder, be careful in handling the piston rings. Despite

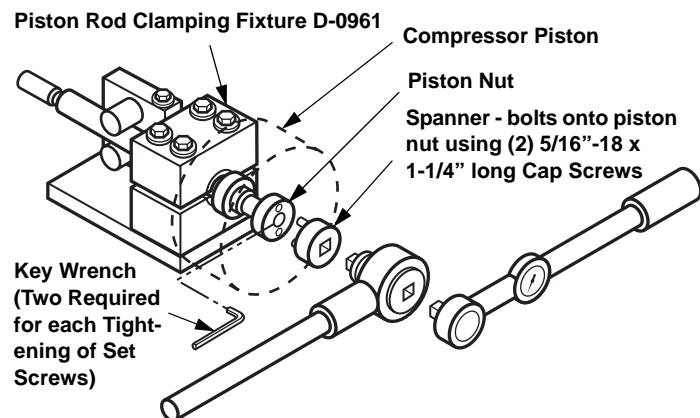
their toughness in service, rings are fragile with regard to removal. Always handle them with clean tools and hands protecting the rings from nicks, marring, and bending. Move the piston out of the cylinder until a fraction of the first ring clears the cylinder. Encircle the ring by hand until it is clear and remove it. Use this same procedure to remove the succeeding rings and wear band, if applicable.

- Slide the piston rod out of the head end. The threaded crosshead end of the rod is 1/8 inches (3 mm) smaller in diameter than the inside diameter of the packing. Using extreme care, slowly slide the piston rod through the packing to avoid damaging the rod threads or the packing rings.

## Piston and Rod Disassembly

The Piston and Rod Clamping Fixture shown in the Figure will be useful for the piston and rod disassembly and reassembly operations. This fixture may be purchased from Ariel.

- Clamp the piston and rod assembly in the special Clamping Fixture (D-0961), using the bushing for a 1-1/8" rod size (see Figure). Tighten the four 12-point cap screws to prevent the rod from turning. The fixture will properly hold the piston rod to prevent damage to the parts and promote safety during disassembly and reassembly. The Clamping Fixture must be securely bolted down to prevent it from turning with the piston rod. It should be at a convenient height of approximately three feet or 0.9 meters. Remove the setscrews from the piston nut. Although the piston nut has been staked to lock the setscrews, they can be forced out, by turning with an Allen key wrench, past the small lip that has been formed.



**FIGURE 5-21 PISTON AND ROD CLAMPING FIXTURE**

### **! CAUTION**

**TRAPPED GAS PRESSURE IN HOLLOW PISTONS CAN PRESENT A PERSONAL SAFETY HAZARD WHEN SERVICING THE PISTON AND ROD ASSEMBLY. WORK IN A WELL VENTILATED, NON SPARKING AREA. DO NOT BREATHE GAS EMITTED FROM PISTONS WHEN VENTING TRAPPED GAS.**

- Remove piston nut using the piston turning/piston nut torquing tool (see Figure 7-1 on page 7-2). Two 5/16-18 x 1-1/4 in. bolts should be used to secure the tool

to the nut

3. After the piston nut has been removed, the piston and collar will slip off the end of the rod.

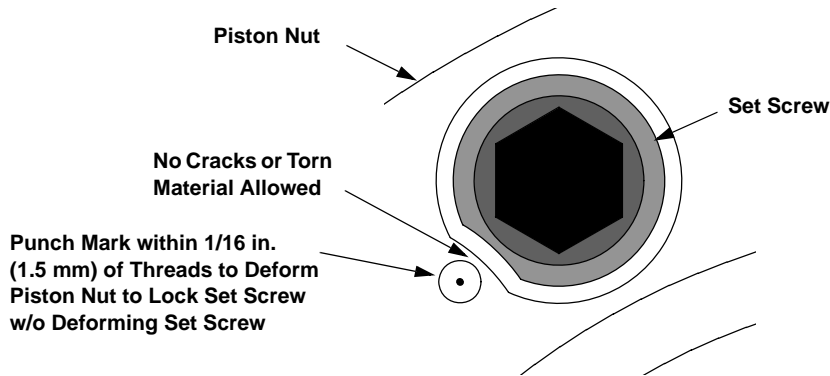
## Piston and Rod Reassembly

1. Clean all piston and rod assembly parts thoroughly. Be sure piston is internally clean and dry.
2. Inspect each part for nicks, burrs or scratches and dress surfaces with a fine grit stone as required.
3. Inspect the piston rod threads and collar shoulder. Threads should be clean and free of burrs. Fit collar and nut into piston to verify the outside diameter fits, and turn freely by hand in the piston. Install the collar and nut onto the piston rod to verify that the inside diameter fits and rotates freely. Run the piston nut down by hand until the rod threads protrude to verify freedom of thread engagement. Remove nut and collar.
4. Check piston rings to determine wear (see "Determining Ring Wear:" on page 5-32). Replace piston rings as required.
5. Clamp the piston rod in Torque Fixture D-0961. See Figure 5-21 on Page 5-28.
6. Apply a thin coat of Never-Seez, regular grade, to piston rod shoulder and rod collar locating band, and collar face in contact with the piston, then slide collar onto rod.
7. Apply a thin coat of Never-Seez, regular grade, to the piston rod threads at the piston end, then slide piston onto rod and collar.

**NOTE: IF ONE END OF SINGLE PIECE PISTONS ARE MACHINED 0.001 IN. (0.03 mm) UNDERSIZE ACROSS A 3/4 IN. (20 mm) WIDE BAND (FOR MANUFACTURING PURPOSES); THIS IS THE HEAD END OF THE PISTON.**

8. Apply a thin coat of Never-Seez, regular grade, to the piston nut threads and piston mating face. Install nut and hand tighten to make up the piston and rod assembly.
9. Use the piston turning/piston nut torquing tool and a torque wrench to tighten the piston nut. The two dowels on the turning tool fit holes in the nut and two 5/16-18 x 1-1/4 in. bolts should be used to secure the tool to the nut. Tighten the piston nut to the recommended torque in Table 1-12 on page 1-16.
10. After tightening nut, the piston rod should not protrude more than 0.010 in. (0.25 mm) past the piston face.
11. Apply a thin coat of Never-Seez, Regular Grade, to two new Allen set screws. Two new Allen key wrenches are also required per nut at each tightening and are discarded after their one time destructive use. Install the set screws and tighten so that the Allen wrench is permanently deformed by tightening past its yield point (twisted through an additional 15° arc). A piece of heavy wall tubing or equal of a proper inside diameter to fit over the Allen wrench is required to extend the "handle" end of the wrench to achieve proper tightening. The Allen wrenches used must conform to ASME B18.3 requirements for hexagonal keys.
12. Use a 60° center punch to prick-punch the piston nut, within 1/16 in. (1.5 mm) of the set screw threads, to stake the set screws in place. Prick-punch marks should deform the nut to lock the set screws without deforming the set screw. The staked piston nut must not exhibit any cracks or torn material that might

allow chips to come loose in service. See Figure 5-22 on Page 5-30.



**FIGURE 5-22 STAKING COMPRESSOR PISTON NUT TO LOCK SET SCREWS**

13. Weigh the piston rod assembly with piston rings, and wear bands if applicable, included. Weigh parts on a calibrated scale to 0.1 pounds (0.05 kg). Stamp the weight on the piston's head end. Remove any raised lips caused by stamping using a fine grit flat stone to avoid clearance measurement errors. Record this weight for future reference.

## Piston and Rod - Installation

1. With the crosshead, wiper packing and piston rod packing case installed, install the piston rod assembly with piston rings into the cylinder. The threaded crosshead end of the rod is 1/8 inches (3 mm) smaller than the inside diameter of the packing. It is not necessary to use an entering sleeve if reasonable care is taken, but a plastic sleeve may be helpful to be sure packing rings are not damaged. A piston rod entering sleeve is available from Ariel as a purchased separately tool, see Figure 7-2 on page 7-3. See "Piston Rings - Installation" on page 5-32 and "Wear Band - Installation" on page 5-33.
2. As the piston enters the cylinder, encircle the first ring by hand to allow it to enter the cylinder without damage. Use the same procedure for succeeding rings, and wear band if applicable.
3. Be sure that the crosshead-balance nut seating surfaces are flat and free of burrs. Dress with a fine grit flat stone as required. The piston threads are to be lubricated with a thin coat of Never Seez, regular grade, and the crosshead-balance nut seating surfaces with new oil (same grade as used in the frame).
4. With the setscrew cup points on the crosshead side of the crosshead-balance nut, re-install the nut onto the piston rod. Turn nut on to rod threads to allow enough clearance to attach the rod to the crosshead.
5. Use the piston turning/piston nut torquing tool a speed wrench to screw the piston rod into the crosshead. The two dowels on the turning tool fit holes in the piston nut or piston/rod as applicable.
6. Follow the instructions in "Crosshead - Installation" on page 5-13 for tightening the crosshead-balance nut and setting piston end clearance to secure the piston rod to the crosshead, and for closing the cylinder and crosshead guide. Check piston end clearance, piston rod run-out and crosshead clearance to specifications.

## Piston Rod Run Out

Check piston rod run out after installing a new unit, after relocating a unit or after any maintenance that could affect rod run out.

Verify that the crosshead guides are properly shimmed to level. Verify that the crossheads are in direct contact with the bottom guide. A 0.0015 inches (0.04 mm) feeler stock should not be able to be inserted more than 1/2 inches (13 mm) at all four corners of the crosshead.

Position the dial indicator<sup>1</sup> stem against the piston rod, close to the packing case. Set the indicator to zero with the piston toward the crank end. Readings are to be taken in both the vertical and horizontal directions. When measuring vertical rod movement, upward movement will be recorded as positive, downward movement will be recorded as negative. When measuring horizontal rod movement, rod movement toward the auxiliary end of the frame, will be recorded as a positive reading, movement toward the drive end of the frame will be recorded as a negative reading. Copy Table 5-1 to record readings. Bar over crankshaft by hand and record readings at mid-stroke and with piston at the head end.

**TABLE 5-1 PISTON ROD RUN OUT**

THROW NUMBER:		1	2
Vertical	Piston @ CE	0	0
	Mid-Stroke		
	Piston @ HE		
Horizontal	Piston @ CE	0	0
	Mid-Stroke		
	Piston @ HE		

Compare readings to Table 5-2.

**TABLE 5-2 MAXIMUM ACCEPTABLE PISTON ROD RUN OUT READINGS**

DIRECTION	JGM, JGN, JGP & JGQ		JGI
	INCHES	(mm)	
Vertical	0.0010	(0.025)	N/A
Horizontal	0.0005	(0.013)	

If a vertical reading is greater than the maximum acceptable reading, the following procedure is used to determine acceptability: With the piston at the head end, use feeler gages to determine clearance at the top of the piston. On rider ring pistons this clearance is over the band. Feeler top clearance is divided by ( $\div$ ) 2 and then the following amount is subtracted: (-)0.003 inches (0.08 mm). Place a feeler of this calculated thickness under the bottom of the piston. Place the feeler under the wear band on wear band pistons. This feeler should be long enough to stay under the piston as the piston is moved throughout its stroke. Re-measure vertical run out and compare to acceptable limits in the table above. The horizontal

1. Use a 0.0001 inches (0.001 mm) increment dial indicator.

readings, taken without the use of feelers are to be used for acceptance. Copy Table 5-3 and record calculations and readings.

**TABLE 5-3 FEELER THICKNESS TO CORRECT FOR PISTON WEIGHT**

LINE	THROW NUMBER:	1	2
1.	Top Feeler Clearance		
2.	Line 1 (Divided by 2)		
3.	Line 2 - 0.003 in. (-0.08 mm)	- 0.003 in. (-0.08 mm)	- 0.003 in. (-0.08 mm)
4.	Bottom Feeler Thickness		
5.	Vertical - Piston @ CE	0	0
6.	Vertical - Piston @ HE		

If readings are not within acceptable limits after replacing worn parts and correcting any piping misalignment, the piston rod assembly should be replaced.

## Piston Rings

JGI, JGM, JGP, JGN and JGQ cylinders use one-piece angle cut filled Teflon piston rings.

### Determining Ring Wear:

Ariel recommends replacing rings when the end gap has increased three times the new dimension. To measure the end gaps, insert the rings in the cylinders without pistons. (See Table 1-7 on page 1-12 or Table 1-9 on page 1-14 for new end gap dimensions.)

### Removal:

See paragraph 3. at "Piston and Rod" on page 5-27 for piston ring removal.

### Piston Rings - Installation

1. Place the rings over the grooves in the piston. Compress the Teflon one-piece rings by hand.
2. With the rings fully compressed in the grooves, insert the rod and piston into the cylinder. Make sure the rings stay in place while inserting the piston and rod.

**NOTE: RING GAPS ARE TO BE STAGGERED AROUND THE PISTON, RATHER THAN IN LINE.**

3. Follow the steps under "Piston and Rod - Installation" on page 5-30.

## Wear Bands

1-3/4JG-FS-HE and 1-3/4SG-FS-HE cylinder class pistons use a one-piece angle cut Teflon wear band.

## Determining Wear Band Wear:

Since the wear band does not work as a sealing ring, end gap is not critical. The amount of wear band projection beyond the outer diameter of the piston is important. Wear band projection can be checked by measuring piston to cylinder bore clearance at the bottom of the bore. This can be done without removing the piston from the cylinder. Replace the wear band before it has worn enough to allow the piston to touch the cylinder bore.

## Wear Band - Installation

Install the wear band as if it was another piston ring as above. Wear bands are only used on 1-3/4JG-FS-HE and 1-3/4SG-FS-HE cylinder class pistons.

## Piston Rod Pressure Packing - Removal

**CAUTION!: BE SURE THAT ALL PRESSURE IS RELIEVED FROM THE COMPRESSOR CYLINDERS PRIOR TO REMOVING PACKING.**

1. Remove the piston and piston rod. See "Piston and Rod - Removal" on page 5-27.
2. Remove packing diaphragm and oil wiper packing.
3. Disconnect all tubing connections from the top of the packing flange and the primary vent tube from the bottom of the flange. Remove the twelve point cap screws that hold the pressure packing flange to the cylinder.
4. At this point do not remove the small nuts from the studs. These studs hold the entire packing case together so it can be removed as an assembly.
5. Screw two short 3/8-16 UNC cap screws into the two tapped holes provided in the crankend face of the packing flange. An appropriate prybar under the heads of the cap screws can be used to pull the entire pressure packing out into the crosshead guide. It will then come out through the side opening of the guide. The pressure packing may now be taken to a clean place for disassembly.
6. Set the pressure packing on a clean surface on its nose cup or cylinder end. Three long tie studs hold the pressure packing together. The stud holes are not equally spaced. This prevents the stack of parts from being aligned incorrectly. Remove the stud nuts and the pressure packing can be unstacked. Replace these nuts each time the pressure packing is serviced.
7. Ring wear can be determined by placing the assembled rings, (note match-marks), on the piston rod. Check end gap clearance. If the ends butt, or nearly butt, they should be replaced by new rings. See "Types of Piston Rod Packing Rings" on page 5-35.
8. Fins or wire edges on the rings due to wear should be carefully filed off so that all matching edges will be square.
9. The metal gasket on the end cup can be pried loose with a sharp awl. Be careful not to scratch the sides of the gasket groove.
10. Before reassembly be certain all parts are perfectly clean.



## Piston Rod Packing - Reassembly

1. Be sure to refer to the pressure packing assembly in the Ariel Parts Book. Please contact your distributor if you do not have a Parts Book. A pressure packing assembly drawing also is packaged with each pressure packing re-build kit.
2. Care must be taken to prevent scratching the mating surfaces of the cups, which can cause problems. Cup surfaces must be clean and dry when being re-assembled.
3. If installing a new set of rod rings in an existing packing case, the case parts need to be inspected for wear. Cups should be smooth and flat on the back side where the rod rings must seal. If the cups or grooves have worn concave or tapered, they should be reground or relapped. Do not reduce the cup thickness to less than the rework dimension shown on the packing assembly drawing in the Ariel Parts Book. It is rarely necessary to alter the crosshead side of the cups, however, if this is found necessary, care must be taken so that the correct side clearance for the renewal rings is not destroyed.

**NOTE: IF PREMATURE WEAR IS SUSPECTED, REFER TO THE ARIEL "LUBE TYPE & RATE RECOMMENDATIONS" ON PAGE 4-26.**

4. Before a packing case is installed, it should always be disassembled and thoroughly cleaned in an appropriate solvent for the intended service.
5. Before assembling the rings into the case, the following is recommended: Put each ring set individually onto the rod and check the total end gap. See "Types of Piston Rod Packing Rings" on page 5-35 for end gap tolerances. File at a gap to restore total end gap within tolerance. With the ring set on the rod, shine a light from behind the ring, if any light is observed between the ring and the rod, the ring set is not acceptable.
6. Make sure that each rod ring and cup is properly positioned and that rings are liberally coated with a clean lubricant before reassembly. Only use the same lubricant that is used in the force feed lube system. Examine all parts for unusual nicks or burrs which might interfere with the free floating of the rod ring in the cups. Particular care should be taken with rod rings made of soft materials, such as bronze or TFE, and it is extremely important that wiper rings be handled and installed so as to prevent damage to the scraping edges.
7. Parts should be laid out on a work bench so that they can be installed progressively with each in its correct position and the rod rings with their proper faces toward the pressure. Be sure that the tie studs are completely screwed into the end cup. The stud holes are not equally spaced. This prevents the stack of parts from being aligned incorrectly. Note that all rod ring segments are carefully lettered and must be assembled accordingly. This is most important for proper sealing. Center, side-loaded AL rings prior to tightening tie stud nuts. Tighten the tie stud nuts to the recommended torque value given in Table 1-12 on page 1-16. Make sure that all rings move freely, radially, in their grooves using your fingers. Side loaded rings will be snug, but should still move using your fingers. Be sure these rings are centered. If the packing is water cooled, see "Water-Cooled Piston Rod Packing" on page 5-38.
8. For new installations, care must be given to the cleaning of all accumulated dirt in the lines and compressor because foreign material will lodge in the packing to become destructively abrasive. Refer to "Oil System Cleanliness" on Page 4-15.

9. Prior to installing the packing case into the cylinder, the end cup gasket must be inspected for nicks and damage that would cause it to leak in service. When in doubt, replace the gasket with a new one.
10. Prior to installing the packing case into the cylinder, be sure the gasket surfaces in the packing counter bore on the crank end of the cylinder are clean and not scratched.
11. Re-install the complete packing case assembly with the oil supply point on top. Use the rod packing bolts to pull the packing into place, but do not tighten at this time.
12. Re-install the packing diaphragm and wiper packing.
13. Re-install the piston and rod. Follow the steps under "Piston and Rod - Installation" on page 5-30.
14. After the crosshead-balance nut has been tightened, tighten the rod packing bolts evenly in 25% increments to the recommended torque in Table 1-12 on page 1-16. This procedure will bring the pressure packing up square on its nose gasket. Alignment is readily accomplished by the use of feelers to maintain a uniform clearance all around between the case bore and the rod.

**NOTE: THE FINAL TORQUE FOR THE ROD PACKING BOLTS SHOULD BE REPEATED UNTIL NO TURNING OF THE FASTENERS IS OBSERVED. THE TORQUE ON THESE FASTENERS SHOULD BE RE-CHECKED AT THE NEXT SERVICE INTERVAL.**

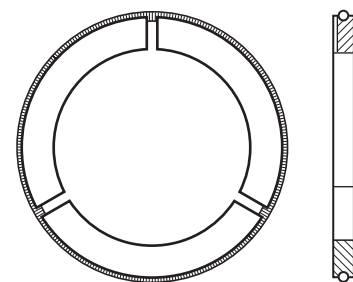
15. Retighten the small tie stud nuts. Re-install the tubing connections for the oil supply, primary vent and/or coolant. Take care not to cross-thread the tubing nuts. Tubing nuts must be tight. Refer to the Swaglock "Tube Fitting Instructions" on the Ariel web site in Vendor Literature.

**NOTE: AFTER INSTALLING THE NEW PRESSURE PACKING RINGS, REFER TO "FORCE FEED LUBRICATION SYSTEM" ON PAGE 4-51 FOR INSTRUCTIONS FOR PRIMING THE FORCE FEED LUBE SYSTEM. PRIMING SHOULD BE REPEATED EACH TIME A COMPRESSOR IS STARTED BECAUSE OIL LINES MAY HAVE BEEN BLED DURING DOWN TIME. FOLLOW INSTRUCTIONS IN "FORCE FEED LUBRICATOR ADJUSTMENT" ON PAGE 3-12 FOR LUBRICATION RATES THAT ARE RECOMMENDED FOR BREAK-IN OF A NEW MACHINE. BREAK-IN LUBE RATES ARE TWICE THE NORMAL RATES - OR ONE-HALF THE NORMAL INDICATOR PIN CYCLE TIME.**

## Types of Piston Rod Packing Rings

### Type "P" Pressure Breaker

This is a single ring. It is cut radially into three equal segments. Total end clearance for the ring is 0.023 to 0.029 inches (0.6 to 0.7 mm) for PEEK rings and 0.011 to 0.017 inches (0.3 to 0.4 mm) for bronze and cast iron rings. Maintain the end gap by adjusting ring gap or replacing the ring. This ring breaks down or slows the gas flow without sealing it completely.

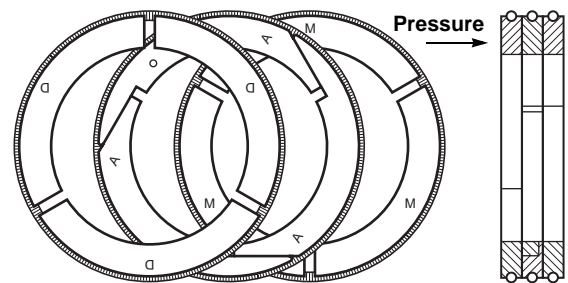


Letters toward pressure/cylinder

**FIGURE 5-23 TYPE "P" PRESSURE BREAKER**

## Type "BTR" Single Acting Seal Set

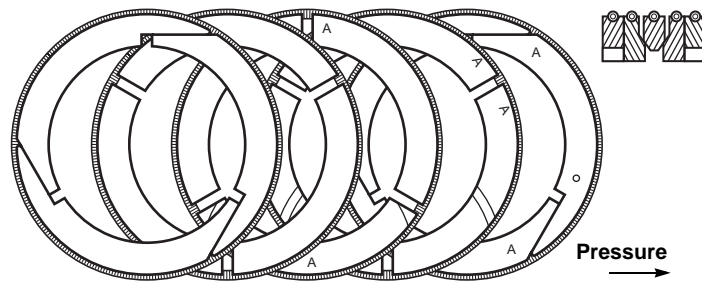
This set is made up of three rings. It seals in one direction only. The first ring (pressure side) is radially cut. The second ring is a tangentially step cut ring. The first two rings are doweled so the cuts are staggered from one ring to the other. The installed total end gap is 1/8 to 5/32 inches (3 to 4 mm) for Teflon and 7/32 to 1/4 inches (5 to 6 mm) for bronze and PEEK. Maintain the end gap by adjusting ring gap or replacing the ring. The third ring is called a back-up ring and is radially cut. The bore in this ring is larger than the rod diameter. This allows the radial joints to be tight together forming a gas seal. No dowel is necessary for this ring.



**FIGURE 5-24 TYPE "BTR" SINGLE ACTING SEAL SET**

## Type "AL" Double Acting Seal Set

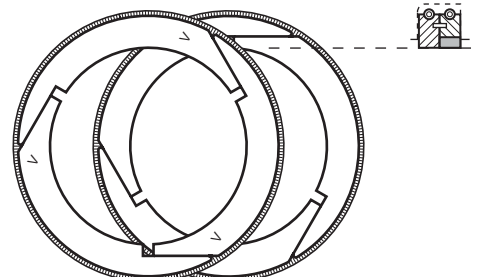
This set is made up of five Teflon rings. The center three are radial cut and the two outboard rings are step-tangent cut. The last two rings on each end are doweled together to stagger the cuts. The center ring, along with the two adjacent rings, form a wedge that overcomes rod friction and forces the set to have constant contact against both groove faces during either direction of rod travel. The installed total end gap is 1/8 to 5/32 inches (3 to 4 mm) for rings 1, 2, 4 and 5. This ring set is designed for gas purge applications. Maintain end gap by adjusting ring gap or replacing the ring. "AL" rings must be centered when installed in the packing case. Since the AL ring set seals end-to-end in the cup and with the low lube rate, newly installed rings could run virtually dry for the first few hours of operation. To avoid damage to the rings and rod, copiously oil the ring set during installation, before the rod is installed. Only use the same lubricant that is used in the force feed lube system.



**FIGURE 5-25 TYPE "AL" DOUBLE ACTING SEAL SET**

## Type "BD" Double Acting Seal Set

This set consists of two tangentially step cut rings. The rings are doweled so the tangential cuts are staggered from one ring to the other. The installed total end gap is 1/8 to 5/32 inches (3 to 4 mm) for Teflon and 7/32 to 1/4 inches (5 to 6 mm) for bronze and PEEK. Maintain end gap by adjusting ring gap or replacing the ring. The set is double acting in that it will seal in either direction. It is used in cylinders operating near atmospheric pressure to prevent air from entering the cylinder. Install with the match mark letters facing the pressure.



**FIGURE 5-26 TYPE "BD" DOUBLE ACTING**

## Type "3RWS" Oil Wiper Set

The three cast iron rings in this set are radially cut and doweled to stagger the cuts from one ring to the other. They keep crankcase oil out of the packing and cylinder. Assemble with the blank face towards the oil (crankcase) and the slotted side towards the pressure packing. Total end gap installed is 3/16 to 7/32 in. (5 to 6 mm). Maintain end gap by adjusting ring gap or replacing the ring.

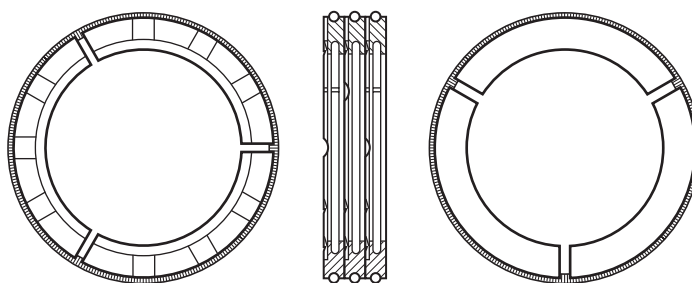
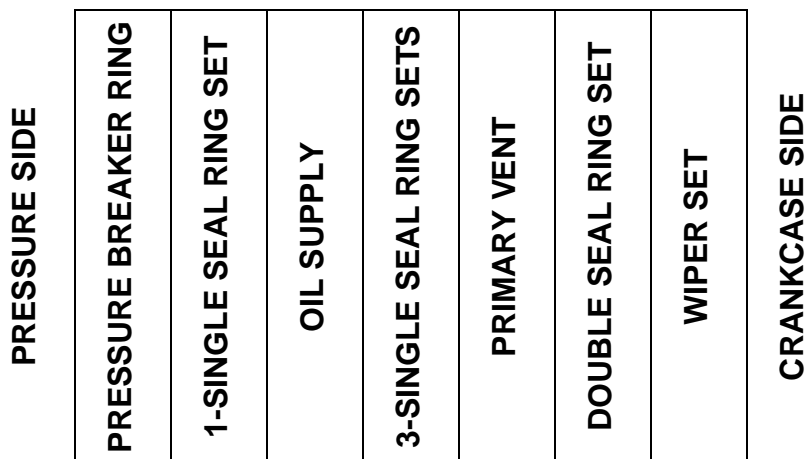


FIGURE 5-27 TYPE "3RWS" WIPER SET

## Typical Arrangement of Piston Rod Packing Rings

The general arrangement of the oil supply, seal ring and vent locations is shown below:



The oil wiper rings and a seal ring set are carried on a separate diaphragm in the crosshead guide when a "two compartment distance piece" is supplied.

**NOTE: REFER TO THE PACKING ASSEMBLY IN THE ARIEL PARTS BOOK. SEE FIGURE 2-4 ON PAGE 2-13 FOR PACKING TUBING AND DISTANCE PIECE VENTING AND FIGURE 2-5 ON PAGE 2-14 FOR PACKING LUBRICATION AND VENTING.**

## Piston Rod Packing Ring Material

In the past, bronze was the standard material for Ariel packing rings. Bronze, however, is unsatisfactory for sour gas service, (hydrogen sulfide in the gas). PEEK, cast iron and Teflon provide outstanding service with sour gas, and since they perform equally well with sweet gas, they are now the standard materials.

A typical packing will have a PEEK pressure breaker, Teflon/cast iron single acting rings, all Teflon double acting rings, and a cast iron wiper set. The Teflon is glass reinforced and impregnated with molybdenum disulfide. This provides a strong, slick material to reduce friction and wear.

## Water-Cooled Piston Rod Packing

When any disassembly of a “water”-cooled rod packing case is required from the as supplied - as received condition from the manufacturer, proper reassembly and testing is required. This is to test the cases for leaks.

### Reassembly

Refer to “Piston and Rod Reassembly” on page 5-29 and “Types of Piston Rod Packing Rings” on page 5-35.

Be sure to refer to the pressure packing assembly in the Ariel Parts Book. Ariel provides a Parts Book for each unit. Please contact your distributor if you do not have the Parts Book. A pressure packing assembly drawing also is packaged with each pressure packing re-build kit.

“Water”-cooled cases are lapped, and special care must be taken to prevent scratching the mating surfaces of the cups, which can cause significant problems. Cup surfaces must be clean and dry when being re-assembled.

The cups are numbered on the outside diameter and are to be assembled in consecutive order, starting with the end cup. Refer to the pressure packing assembly the Ariel Parts Book and Figure 5-28 on Page 5-38. The studs are offset so the cups will only fit one way.

Make sure the tie studs are completely screwed into the end cup. Put the proper ring in the groove and facing the proper direction. Long tie studs hold the pressure packing together. The stud holes are not equally spaced. This prevents the stack of parts from being aligned incorrectly. Be careful when sliding parts onto the tie studs to be sure that no scratching occurs to the lapped faces. Unless non-lube, rings are to be lightly coated with new clean lubricant before reassembly. Only use the same lubricant that is used in the force feed lube system.

Install second cup next, put the rings in place, and make sure the two (2) small O-rings are in place around the coolant holes.

Continue assembling the remaining parts in the proper configuration to the packing case drawing, in consecutive order, by repeating the above step.

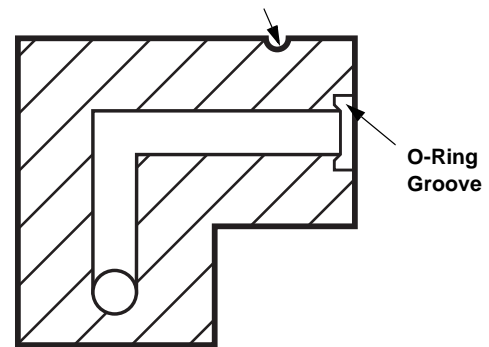
Install tie stud-nuts and tighten to the values given in Table 1-12 on page 1-16. Make sure that all rings move freely, radially, in their grooves using fingers.

### Testing

100 percent verification of function is required for all internal passages.

The passages are to be checked by blowing clean, dry compressed air through the connection taps on the flange and verifying that air is exiting at the proper holes. When air is applied to the connection tap stamped “Coolant In”, air should be exiting the connection tap stamped

Coolant Turnaround Cup Circumferential Identification Groove (All - beginning in 2006)



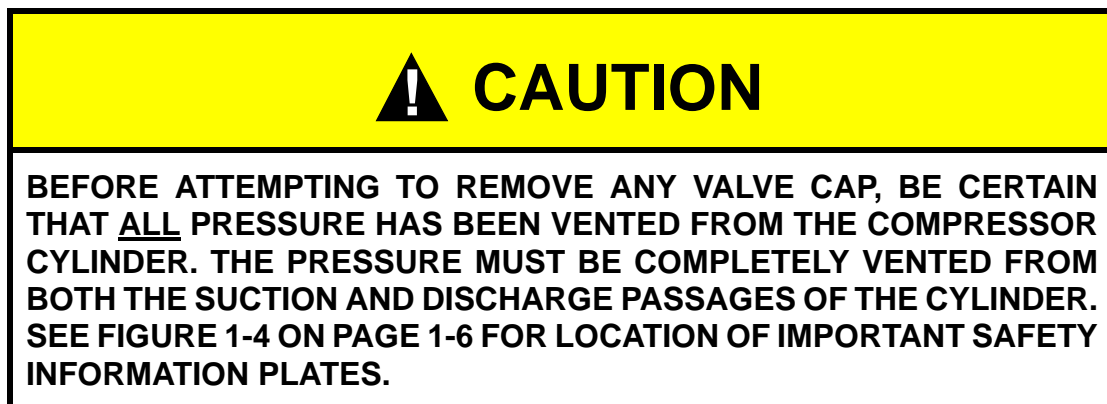
**FIGURE 5-28 “WATER”-COOLED PACKING CASE TURNAROUND CUP**

“Coolant Out”, or if air is applied to the connection tap stamped “Lube”, air should be exiting at the appropriate cup on the inside diameter of the case.

Pressure leak test packing cases as follows:

1. Apply 60 to 100 psi (4 to 7 bar) dry, compressed air pressure to the connection tap stamped “Coolant In”. For water cooled rod packing cases in non-lube service, compressed air is to be oil free. Air should exit at the connection tap stamped “Coolant Out”. Air applied to the connection tap stamped “Lube” should exit at the appropriate cup on the inside diameter of the case.
2. Plug the connection tap stamped “Coolant Out” and apply 60 to 100 psi (4 to 7 bar) dry, compressed air pressure to the connection tap stamped “Coolant In” through a ball valve with a calibrated pressure gauge located between the ball valve and packing case. Close the ball valve and disconnect the air supply. There should be no pressure drop for five minutes minimum. Cases which fail this testing procedure are to be disassembled, inspected, repaired, re-assembled and re-tested. Packing cases may be bolted into place in a cylinder head to aid sealing, using proper bolting and tightening torques.

## Valves



## Valves - Removal

1. Slightly loosen all of the bolts on each valve cap. With all the bolts loose, the cap should stay in its original position. If it pushes out on its own accord, **STOP!** Take steps to completely vent the cylinder. See Caution above. A typical valve assembly is shown in Figure 5-29 on Page 5-41.
2. After all the above safety checks and with cap screws still in place but loosened, move the valve-cap out until the O-ring clears the cylinder to be sure that the cylinder is properly vented. A pair of appropriate pry bars, one on each side of the cap, will help pry it out.
3. Remove cap screws and valve cap.

**CAUTION!:** BE CAREFUL TO PREVENT THE VALVE CAP, RETAINER AND/OR VALVE FROM FALLING OUT OF BOTTOM VALVE POCKETS TO PREVENT THE POTENTIAL OF PERSONAL INJURY.

4. With the retainer still in place, screw a valve puller tool over the valve center bolt. See Figure 7-1 on page 7-2.
5. It may be necessary to loosen the plastic thumb screw retainer-keeper in the valve retainers.
6. For high pressure applications that use a metallic gasket seal, the cylinder will vent when cap screws are first loosened.
7. Now the valve and retainer can be pulled out together. For cylinder class 1-3/4JG-FS-HE and 2-1/2JG-FS-HE tandem cylinders, the suction and discharge piping and cylinder head must be removed to gain access to the concentric valve. A concentric valve combines the suction and discharge valves in one assembly. See Caution at "Piston and Rod" on page 5-27.
8. In most cases the flat metal gasket will remain in the pocket. It is difficult to see. A flashlight and a small mirror on an adjustable rod are the best tools to see the gasket clearly. On cylinders with horizontal valves, the gasket may fall into the gas passage. A small magnet on a flexible extension rod will help fish it out. This gasket should be replaced if damaged.

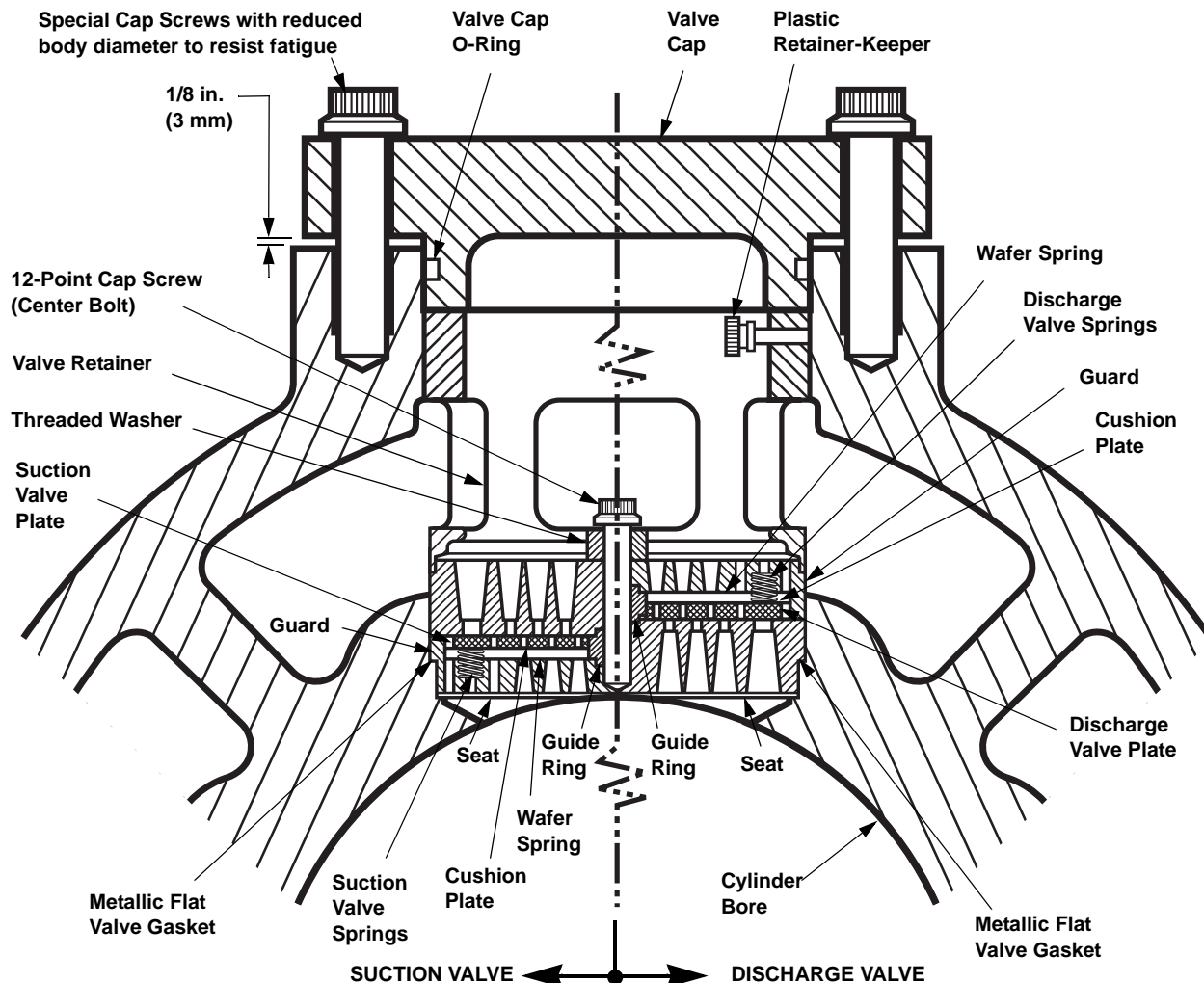
## Valves - Maintenance

Ariel uses valves manufactured by Hoerbiger Corporation. Before servicing any valve refer to the correct valve assembly drawing and parts list and Hoerbiger's literature in the Ariel Parts Book. On the valve assembly drawing you will notice that valves have different springing for different pressure levels. The cylinder cover sheet in the Parts Book lists the valve originally supplied with each cylinder. If different operating pressures are encountered, then different springs may be required.

The suction valve must be selected on the basis of operating suction pressure and the discharge valve for operating discharge pressure. Proper valve spring selection is also based upon the operating speed (RPM), gas specific gravity and the suction temperature of the gas.

Contact Ariel in Mount Vernon, for assistance in valve selection.

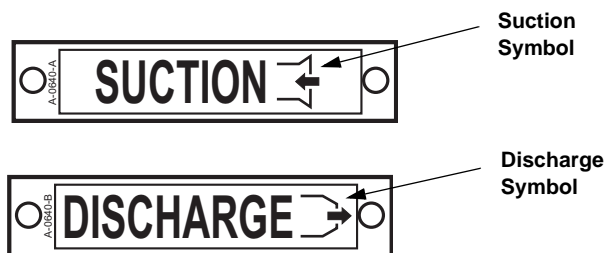




**FIGURE 5-29 TYPICAL VALVE ASSEMBLIES**

### Valves - Reassembly

1. The 1/32 inches (0.8 mm) thick soft metallic flat gasket should be coated with an anti-seize lubricant. It can then be either inserted into the valve pocket or stuck onto the valve. In either case, care must be taken to keep this gasket from falling into the gas passage.
2. Be sure that suction valves are installed only in suction pockets and discharge valves only in discharge pockets. The valve pockets have identification plates. All valves are installed with the valve fastener(s) positioned away from the cylinder bore. If a valve is not marked for suction or discharge, or to verify the type, depress the valve plate by hand. It is recommended that a



**FIGURE 5-30 COMPRESSOR CYLINDER VALVE POCKET IDENTIFACATION PLATES**



tool which is softer than the valve plate material be used or care be exercised to prevent damage to the plate. A suction valve plate can only be depressed from the valve fastener (bolting) side of the valve, and a discharge valve plate can only be depressed from the side of the valve that goes toward the cylinder bore. Reference Figure 5-29 on page 5-41.

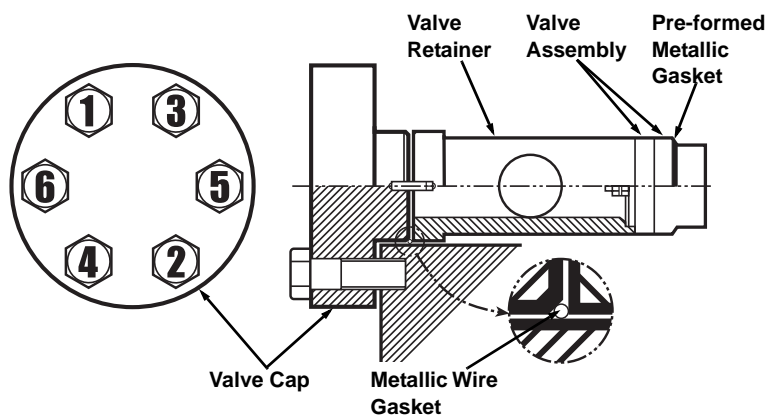
3. Using the proper valve puller/installation tool, illustrated in Figure 7-1 on page 7-2, the valve and the retainer may be inserted into the pocket together. Be sure the valve is properly seated in the pocket. When installed correctly the valve should rotate freely when turned by hand, and the distance from the outer retainer face to the surface of the valve boss on the cylinder will be 1/8 inch (3 mm) shorter than the length of the nose on the valve cap.
4. The retainer keeper is a plastic thumb screw in a threaded hole in the bottom valve retainers. This should be screwed through just far enough to provide friction so that bottom retainers will not fall out while the cap is being installed.
5. Inspect the valve cap o-ring for cuts or gashes and replace it if necessary. Lubricate the o-ring and the nose of the valve cap. Some high pressure cylinders use a soft metallic wire gasket in lieu of the o-ring design. Insert the cap and tighten the bolting evenly to the recommended torque in Table 1-12 on page 1-16. See "Bolt Tightening for Valve Caps" on page 5-42. If the assembly is correct, the distance from the underside of the cap to the valve boss surface on the cylinder will be 1/8 inches (3 mm).

**NOTE: BE CERTAIN ALL PARTS, GASKET FACES, AND MATING SURFACES ARE ABSOLUTELY CLEAN AND ALWAYS USE CLEAN, FRESH OIL ON THE THREADS BEFORE RE-INSTALLING BOLTS.**

## Bolt Tightening for Valve Caps

Proper fastener tightening technique is essential for sealing of valve caps with soft metallic wire gaskets used in some high pressure cylinders. It is important to draw up bolting to full torque in even and gradual steps. Do not allow the valve cap to be tightened with bias on one bolt or to become cocked in the bore. Such bias or cocking can cause uneven crush of the gasket, which could cause a leak and could also cause bolt failure. This step tightening procedure is also recommended for all valve caps.

Install the valve assembly (and high clearance spacer, when applicable), with the flat gasket(s) and valve retainer, in the valve pocket. See "Valves - Reassembly" on page 5-41. For high pressure applications, place a new, proper, soft metallic wire gasket on the retainer and install the valve cap. Be careful not to gouge the bore, distort or damage the wire gasket. Always use a new metallic wire gasket; wire gaskets are not reusable.




**FIGURE 5-31 HIGH PRESSURE VALVE CAP ASSEMBLY**


Lubricate threads and bolt seating surfaces with petroleum type lubricant (except for stainless steel bolting, use a thin coating

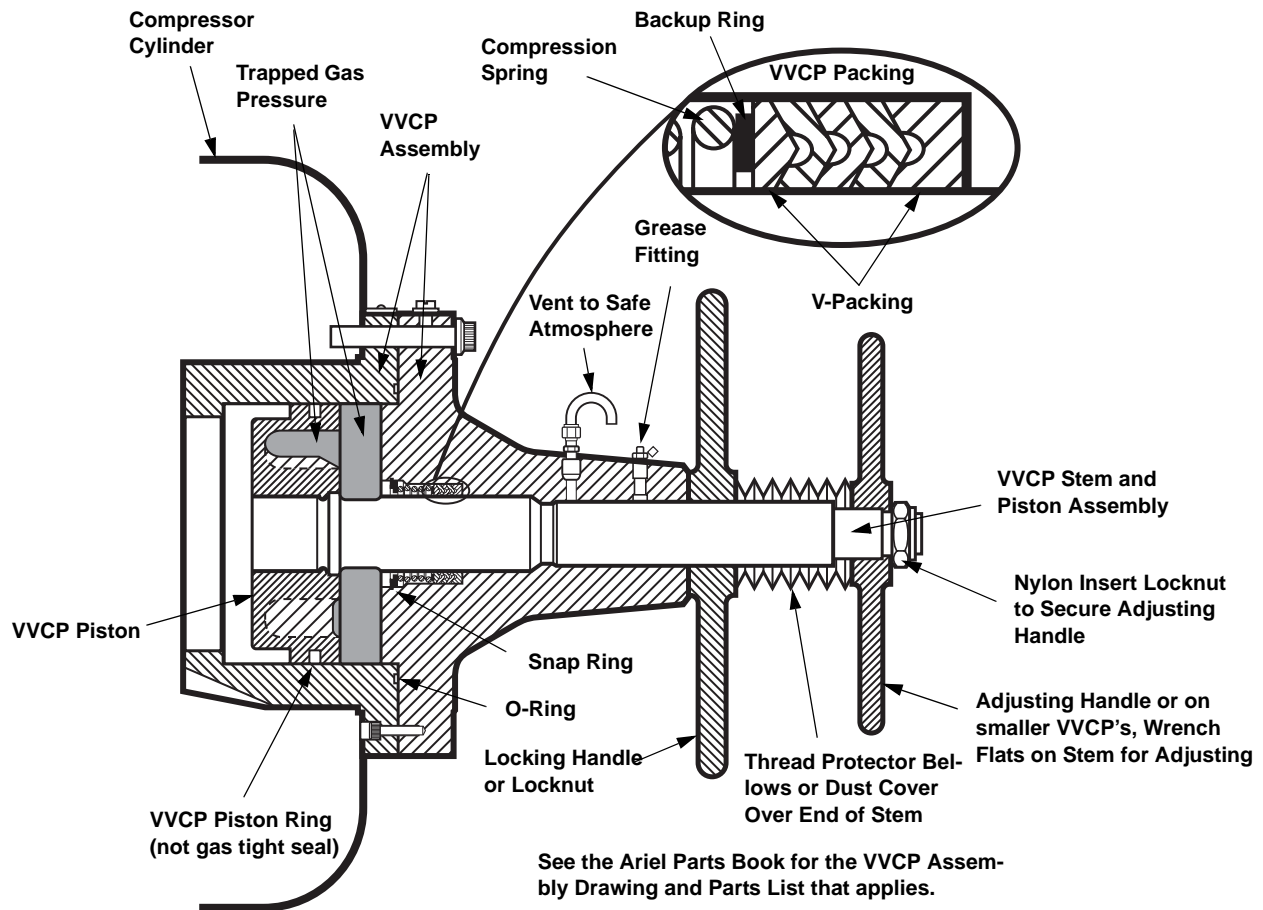
of Never-Seez, regular grade), and install bolting. Do not otherwise use anti-seize compounds on valve cap bolting. Tighten each cap screw until snug using a criss-cross pattern. Next, tighten each bolt to 25% of full torque, moving across from bolt to bolt, in a criss-cross pattern. See Figure 5-31 on Page 5-42, 1-2-3-4-5. Repeat this step for 50%, 75% and 100% of full torque. If the assembly is correct, the distance from the underside of the cap to the valve pocket boss surface on the cylinder will be uniform 1/8 inches (3 mm).

Proper tightening and torquing is important for all valve caps, but is especially important for high pressure valve cap assemblies. High pressure applications have caution plates on the cylinder which are stamped with proper torque values:

 <b>CAUTION</b>
<b>SEVERE PERSONAL INJURY AND PROPERTY DAMAGE CAN RESULT IF VALVE CAP BOLTING IS NOT INSTALLED TO PROPER TORQUE OF _____ FT. LBS. _____ N·M.</b>
<b>REFER TO TECHNICAL MANUAL FOR PROPER TORQUING PROCEDURE.</b>

## **VVCP - Head-End Variable Volume Clearance Pocket**

 <b>CAUTION</b>
<b>TRAPPED GAS PRESSURE CAN PRESENT A PERSONAL SAFETY HAZARD WHEN SERVICING THE VVCP. WORK IN A WELL VENTILATED, NON SPARKING AREA. DO NOT BREATHE GAS EMITTED FROM VVCP WHEN VENTING TRAPPED GAS.</b>



**FIGURE 5-32 COMPRESSOR CYLINDER WITH VVCP - TYPICAL**

## VVCP - Removal

**CAUTION!:** BE SURE THAT ALL PRESSURE IS RELIEVED FROM THE COMPRESSOR CYLINDERS PRIOR TO REMOVING VVCP.

Disconnect VVCP packing vent. Remove the VVCP from the cylinder using similar procedures as when removing a cylinder head. The approximate weights of VVCP's for handling purposes can be found in the current Ariel Performance Program.

## VVCP - Disassembly

For larger VVCP's, unsnap thread protector bellows from the slot in adjusting handle. With the locking handle locked, remove nylon-insert locknut and adjusting handle. Smaller VVCP's are not equipped with an adjusting handle, but have wrench flats on the stem for adjustment. Some smaller VVCP's have a dust cover. The smallest VVCP's have a locking nut in lieu of a locking handle. A hammer or puller may be required to break adjusting handle to stem tapered fit. Loosen the locking handle (or locknut) and unscrew to remove. Remove head bolting to remove VVCP from cylinder. Remove socket head screws at inside of bolt flange and separate the halves of the VVCP. Unscrew the VVCP stem and piston assembly to remove.

## VVCP - Maintenance

To replace or clean the VVCP packing, mechanically depress the packing assembly spring and remove the snap ring. A piece of threaded rod, two hex nuts and two heavy washers may be used to compress the packing assembly. The inner washer must be large enough to catch the packing assembly, and small enough to allow the snap ring to be compressed and removed. Use proper snap ring pliers. Replace the VVCP packing when excessive leakage is noted at the vent. Remove the VVCP piston ring; replace as necessary.

Clean all parts to remove all debris, rust, etc. The stem and piston are permanently attached to each other, do not attempt to disassemble. When replacing the VVCP packing, place new packing between two flat surfaces, such as two pieces of wood and tap wood with hammer to relax the packing elements prior to assembly.

Reassemble the VVCP in reverse order, lubricate and install a new O-ring at the bolt flange between the two-halves. Refer to Section 1 for bolting tightening torque value. Lubricate stem with three to four pumps of all-purpose petroleum grease with a hand pump grease gun at the grease fitting.

To re-install the VVCP on the cylinder, use a new head gasket. Lubricate threads and bolting seating surfaces with petroleum type lubricant and install bolting. Tighten each cap screw until snug using a criss-cross pattern. Next tighten each cap screw to 25 percent of full torque, moving from cap screw to cap screw in a criss-cross pattern. Repeat this step for 50, 75, and 100 percent of full torque. Refer to Section 1 for tightening torque value.

Reconnect VVCP packing vent. Re-install and tighten locking handle (or locknut), install bellows, adjusting handle and Nylon-insert locknut, if applicable. Be sure that thread protector bellows are properly aligned when installing adjusting handle. Tighten Nylon-insert locknut. Refer to Section 1 for tightening torque value. When installing a new VVCP, check total piston end clearance, check crank end/head end feeler gage clearances with VVCP completely closed. Refer to Section 1 for clearances.

## VVCP - Adjustment

VVCP clearance volume may be changed with the compressor running or stopped. Consult the Packager's instructions regarding where to set the VVCP. Also refer to the VVCP data sheet in the Ariel Technical Manual Parts Book.

The VVCP piston ring is designed not to be gas tight, to allow a nearly balanced gas pressure for ease of VVCP adjustment with the cylinder pressurized. Gas pressure behind the VVCP piston normally vents when cylinder is vented. Process debris or rust around the piston ring can make a seal that takes some time to vent. If gas is trapped behind the piston, the VVCP can be adjusted when the cylinder is pressurized, but difficult to turn when cylinder is vented. This problem is corrected by disassembling the VVCP and cleaning.

To adjust volume, loosen stem locking handle (or locknut), so that stem is free to turn. Turn stem by use of adjusting handle on outboard end of shaft (or wrench flats). Turn clockwise to load; counterclockwise to unload the compressor cylinder. See the VVCP instruction plate on the equipment for the dimensional positions for fully closed (load) and fully open (unload). Reference Section 1 for an illustration. Re-tighten stem locking handle (or locknut) to hold stem in place.

## Compressor Cylinder Re-Boring & Bore Restoration Guidelines

Compressor cylinder re-boring and bore restoration guidelines are to be followed for cylinder maintenance to provide efficient, cost-effective operation:

1. If the cylinder bore surface is blemished or gouged, affecting efficiency or causing rapid ring wear, or is more than 0.001 inches per inch of cylinder bore diameter (0.001 mm/mm) out of round or tapered, the cylinder body should be replaced or the bore restored to the guidelines below.
2. It is essential that a cylinder has counterbores to allow for ring over-travel, or future wear would make piston removal very difficult. Ariel compressor cylinders are provided with counterbores that are 0.050 inches (1.27 mm) larger than the nominal cylinder bore. The maximum over-bore on an Ariel cylinder bore diameter is 0.044 inches (1.12 mm) larger than the nominal bore diameter, provided the new main bore is concentric with both counterbores, leaving 0.003 inches (0.08 mm) minimum steps to the counterbores.
3. If the cylinder is bored more than 0.020 inches (0.51 mm) larger than the nominal bore diameter, a special oversize wear band and/or sealing rings may be required depending on pressures and gas conditions. This is more applicable for light gases, such as Hydrogen. Oversize wear bands and piston rings are not available from Ariel. See Section 1 (Ariel Technical Manual) for maximum ring end gaps.
4. In a given cylinder class, a smaller-bore cylinder can be re-machined to the larger-bore diameter and counterbores. (New piston, piston rings, wear band if applicable, re-stamping cylinder data tag, and hydro-testing are required). Re-boring can expose internal casting shrinkage, which would render the cylinder body unusable.

**NOTE: CAUTION: ANY RE-MACHINING OF THE COUNTERBORES IN ORDER TO RESTORE THE BORE OF A SMALLER-BORE CYLINDER OF A GIVEN CYLINDER CLASS REQUIRES HYDRO-TESTING THE CYLINDER BODY AT 1.5 TIMES THE MAWP RATING ON THE CYLINDER DATA TAG BY A QUALIFIED FACILITY, BEFORE RETURNING THE CYLINDER TO SERVICE.**

5. Cylinder design is based on the wall thickness at the counterbores of the larger cylinder bore for any given cylinder class. Therefore, **the larger-bore cylinder counterbores of a cylinder class cannot be machined larger.** In this case, the cylinder should either be replaced or reconditioned. Reconditioning may include aftermarket application of metal spray. Ariel does not provide this service. Contact Ariel for a copy of Reference ER-40 "Thermal Spraying Compressor Cylinder Bores to Return to OEM Dimensions" for additional information.
6. Any re-boring operation will remove the hard nitrided layer in ductile iron cylinders, which is provided to extend the service life of the bore. The user should determine the cylinder bore hardness required for the application. To maintain the OEM hardness level, re-machined iron bore surfaces should be hardened after finish machining by nitriding or other hardening process that does not result in distortion or changes in the bore that are detrimental to operation of the compressor. Resulting bore hardness is to be taken into consideration when metal spraying. Contact Ariel for assistance on cylinder bore hardness requirements.
7. Cylinder re-boring and bore restoration must be done by qualified suppliers and

take into consideration the resulting bore diameters, geometry, surface hardness and finish. Contact Ariel for the applicable dimensions and tolerance limits to help determine inspection limits when restoring cylinder bores and to ensure a mechanically sound product.

## Ethylene Glycol Contamination

Ethylene glycol contamination of a compressor can result from water-cooled compressor rod packing or oil cooler leaks.

Ethylene glycol anti-freeze coolant mixture leaking into the compressor crankcase oil can cause crankshaft seizure due to lack of adequate lubrication. Crankcase oil should be changed as recommended in Section 6, while being routinely sampled and analyzed by a qualified laboratory to verify suitability for continued use, including checking for ethylene glycol contamination.

Even small quantities of ethylene glycol in the oil can be detrimental. If contamination is less than 5 percent, drain oil, replace filters and flush oil system with a 50/50 mixture of butoxyethanol (Dow Chemical Co. Dowanol EB or equal) and 10W oil using a motor driven pump. Flushing should be done on a warm compressor. Bearings should be continuously flushed for 1/2 hour while barring over crankshaft. All surfaces that come in contact with crankcase oil are to be flushed which includes spraying all interior surfaces in the crankcase. Completely drain cleaning mixture, being sure to drain all components of the oil system. Repeat flushing operation using a 60/40 mixture of 10W oil and kerosene or fuel oil. Completely drain system, install new filters and fill crankcase and filters with the proper oil. The coolant leak is to be found and repaired.

If sampling indicates that glycol contamination is greater than 5 percent or the compressor has seized due to contamination, the unit is to be torn down, cleaned with 100 percent butoxyethanol, flushed with kerosene or fuel oil and repaired as required. All surfaces that come in contact with the crankcase oil must be cleaned with butoxyethanol, including all passages and piping, and then flushed with kerosene or fuel oil. Oil and filters must be changed. Coolant leak is to be found and repaired.

Butoxyethanol presents health and safety hazards. Use proper eye and skin protection and adequate ventilation. Do not use near open flame or sparks. See manufacturer's Material Safety Data Sheet for complete details.

Ethylene glycol, butoxyethanol, contaminated oils, and solvents must be properly disposed. A chemical disposal service should be used.

SERIAL NO. F- \_\_\_\_\_ MODEL \_\_\_\_\_ Date \_\_\_\_\_

CRANKSHAFT THRUST (END) CLEARANCE:

CRANKSHAFT SERIAL NUMBER	THRUST CLEARANCE, IN. (mm)

CONNECTING ROD THRUST (SIDE) CLEARANCE, IN. (mm)

THROW NUMBER:	1	2	3	4	5	6

JACK CLEARANCES, IN. (mm)

THROW NUMBER:	1	2	3	4	5	6
MAIN BEARINGS						
CONN. ROD BEARINGS						

If measured clearances exceed the tolerances in Table 1-3 on page 1-10, after installing new bearings, contact your packager or Ariel before proceeding.

DATE	TIME	RPM	OIL PRESSURE FILTER INLET PSIG (bar <sub>g</sub> )	OIL PRESSURE FILTER OUTLET PSIG (bar <sub>g</sub> )	OIL TEMPERATURE INTO FRAME °F (°C)	REMARKS

BEARING CAP TEMPERATURES, °F (°C), AFTER RUN TIME OF:

THROW	10 MINUTES		1 HOUR		4 HOURS	
	MAIN	ROD	MAIN	ROD	MAIN	ROD
1						
2						
3						
4						
5						
6						

## SECTION 6 - TECHNICAL ASSISTANCE

### Recommended Maintenance Intervals

Like all equipment, Ariel compressors do require maintenance. The frequency of maintenance is dictated by the environment in which the compressor is placed, the loads the user imposes on the compressor and the cleanliness of the gas.

First and foremost on the preventative maintenance list is the completion and compliance with the Ariel Corporation Packagers Standard and Compressor Start Up Check List. All items must be adhered to, both before and after start up.

The following is a guide only and, as stated above, may vary due to operating conditions. The time intervals start from the start up date of the unit. If your oil supplier's recommended oil service changes are more frequent than the Ariel recommendations, the supplier's intervals should be followed. Regular oil analysis is recommended. If problems develop the oil should be changed immediately and the cause of the problem determined and corrected.

A log book should be kept with each unit. Every maintenance item can be entered with exacting detail in order that records will be available for tracking maintenance costs per unit and for trouble-shooting.

Operator logs should be reviewed by qualified personnel to determine trends in compressor performance and/or maintenance.

**CAUTION! BE SURE THAT THE COMPRESSOR IS COMPLETELY VENTED TO RELIEVE ALL GAS PRESSURE, AND THE DRIVER WILL NOT EXERT TORQUE ON THE COMPRESSOR CRANKSHAFT THAT COULD RESULT IN INJURY, PRIOR TO TAKING COUPLING READINGS, RE-CHECKING BOLTING TORQUES ON PRESSURE CONTAINING COMPONENTS OR REMOVING ACCESS COVERS FOR PERFORMING INTERNAL INSPECTION OR MAINTENANCE ON THE COMPRESSOR. IN THE CASE OF A DIRECT DRIVE MOTOR, THE BREAKER IS LOCKED OUT. FAILURE TO FOLLOW THESE STEPS CAN RESULT IN SERIOUS PERSONAL INJURY OR DEATH.**

### Daily

After running a new compressor (or after a re-location, re-configuring or major overhaul) for the first 24 hours, shutdown, vent gas system and perform a hot alignment check at coupling within 30 minutes, while barring driver shaft to packager's recommendations. Realign if necessary to hold coupling hub face and rim hot alignment within 0.005 inch (0.13 mm) TIR, except for hub O.D. >17 in. (>43 cm) angular hub-face limit is increased to 0°1' (0.0167°). Also check fastener torque on gas nozzle flange, valve cap, cylinder head, compressor rod



packing flange and, if applicable, crosshead guide to frame bolting. Reference Ariel Technical Manual, Fastener Torque Tightening Values or Toolbox Torque Chart, ER-63. After the first week or 150 hours, repeat this fastener torque check.

If bearing temperatures increase or a visual inspection of the crankcase indicates bearing wear, check main, connecting rod and crankshaft-thrust bearing clearances. Replace affected bearings if clearances are out of tolerances. See the Ariel Technical Manual for instructions and clearance tolerances.

1. Check frame oil pressure. It should be 50 to 60 psig (3.5 to 4.2 bar<sub>g</sub>) when at operating temperature. Compressor inlet oil temperature is 190°F (88°C) maximum.
2. Check frame oil level. It should be visible in the sight glass and approximately mid-level when running, if not, determine and correct cause. Do not overfill. Check oil makeup tank for sufficient oil supply.
3. Check lubricator block cycle time. Refer to information plate on top of lubricator box for correct cycle time. Very dirty or wet gas may require a more frequent cycle time than normal.
4. Check primary and secondary packing vents for blowing. If blowing, determine cause and, if necessary, replace packing internal parts.
5. Check and correct any gas leaks.
6. Check and correct any oil leaks.
7. Check operating pressure and temperatures. If not normal, determine cause of abnormality and correct. It is recommended that a daily log of operating temperatures and pressure be kept for reference.
8. Check shutdown set points.
9. Low oil pressure shutdown 45 psig (3.1 bar<sub>g</sub>) minimum.
10. High discharge gas temperature shutdowns are to be set within 10% or as close as practical above the normal operating discharge temperatures, but not to exceed the "Maximum Discharge Temperature Shutdown Setting" for the service in which the compressor is operating.
11. High and low pressure shutdowns are to be set as close as practical. Consideration should be given to the rod load capacity of the machine.
12. Check lubricator box oil level.
13. Check for unusual noises or vibrations.

## Monthly (in addition to Daily Requirements)

After running a new compressor (or after a re-location, re-configuring or major overhaul) for the first month or 650 hours, shutdown, vent gas system and check fastener torque on gas nozzle flanges, valve caps, cylinder heads and compressor rod packing flanges. Reference Ariel Technical Manual, Fastener Torque Tightening Values or Toolbox Torque Chart, ER-63. Fasteners that turn at the first month check, should be re-checked after the second month or 1300 hours. If loosening persists, consult your packager or Ariel to help determine the cause and recommend the correction.

1. Check and confirm safety shutdown functions.

2. Take a frame oil sample and send to a reputable lubricant laboratory for analysis. See the Ariel Packager's Standards or Technical Manual Lube Section for a listing of what an oil analysis should provide. If the oil analysis results indicate, change oil. If an oil analysis indicates lead, tin or copper particles in the oil, check main, connecting rod and crankshaft-thrust bearing clearances. If bearing clearances are outside of the limits, replace the affected bearings. See the Ariel Technical Manual for instructions and clearance tolerances.

### **Every 6 Months or 4000 Hours (plus Daily/Monthly)**

1. Drain and replace lubricator box oil.
2. Change oil filter or when oil filter differential pressure exceeds the filter change value, see filter information plate on the top cover or Ariel Technical Manual, Lube Section for value.
3. Change oil. A more frequent oil change interval may be required if operating in an extremely dirty environment or if the oil supplier recommends it or if an oil analysis dictates it. A less frequent oil change interval may be allowed if the oil is replenished on a regular basis due to force feed lubricator usage.
4. Clean sintered element in the small oil filter supplied on the force feed lubrication system or every time main oil filter is changed.
5. Clean strainer when oil is changed.
6. Open frame when oil is changed and visually inspect for foreign material. Disassembly is not recommended unless a reason for it is found.
7. Check fluid level in torsional vibration damper (if applicable). Take fluid sample for viscosity testing.
8. Re-tighten hold down stud-nuts to proper torque values. Inspect for frame twist or bending to be sure the main bearing bores are in alignment. Check frame top cover mounting surface flatness tolerance and/or soft foot (reference Ariel document ER-82 or Technical Manual Section 2). For soft foot check, more than 0.002 inch (0.05 mm) pull down requires re-shimming.
9. Realign if necessary to hold coupling hub face and rim hot alignment within 0.005 inch (0.13 mm) TIR, except for hub O.D. >17 in. (>43 cm) angular face limit is increased to 0°1' (0.0167°).
10. Check cylinders for the proper lubrication rates. Reference Ariel Technical Manual, Lube Section for a practical indication using the paper test method.

### **Yearly or 8000 Hours (plus Daily/Monthly/6 Months)**

1. Check main, connecting rod, and crankshaft-thrust bearing clearances with a pry bar and dial indicator. See the Ariel Technical Manual for instructions and clearance tolerances. Any time bearing clearances are outside the limits, replace the affected bearings. Disassembly to check clearances is not recommended. Disassembly should be performed if the pry bar check indicates excessive clearance.
2. Check crosshead guide clearance with feelers and if outside the limits listed in the Ariel Technical Manual, Clearances Table, replace the affected parts.
3. Inspect valves for broken plates and loose center bolts, replace broken parts

and tighten center bolts. Reference Ariel Technical Manual, Fastener Torque Tightening Values or Toolbox Torque Chart, ER-63.

4. Inspect cylinder bores for damage or wear. If the cylinder bore surface is blemished or gouged, efficiency can be affected and/or rapid ring wear can result, or is more than 0.001 inch per inch of cylinder bore diameter (0.001 mm/mm) out of round or tapered, the cylinder body should be replaced or the bore restored. Contact Ariel for re-boring and bore restoration guidelines.
5. Inspect piston ring end gap. Replace rings that are outside the maximum limit listed in the Ariel Technical Manual, Clearance Tables.
6. Inspect piston rods for damage and excessive wear. If gouged or scratched, replace the rod. If the rod is more than 0.005 inch (0.13 mm) under size, out of round more than 0.001 inch (0.03 mm), or tapered more than 0.002 inch (0.05 mm) replace the rod.
7. Rebuild cylinder packing cases.
8. Check and re-calibrate all temperature and pressure gauges.
9. Check and record compressor rod run out.
10. Grease VVCP stem threads at grease fitting, with 2 to 3 pumps of multi-purpose grease using a standard hand pump grease gun.
11. Clean crankcase breather filter.
12. Adjust drive chains.
13. Pressure test distribution blocks.
14. Check gas nozzle flange, valve cap, cylinder heads, compressor rod packing, crosshead pin through bolt, crosshead guide to frame, crosshead guide to cylinder, cylinder mounting flange to forged steel cylinder, distance piece to cylinder, distance piece to crosshead guide and tandem cylinder to cylinder fastener torque.
15. If the compressor is equipped with crankcase over-pressure relief valves, inspect and exercise valves to the manufacturer's recommendations.

### **Every 2 Years or 16,000 Hours (plus Daily/Monthly/6 Months/Yearly)**

1. Check auxiliary end chain drive for sprocket teeth undercutting and chain for excessive stretching.
2. Rebuild oil wiper cases.

### **Every 4 Years or 32,000 Hours (plus Daily/Monthly/6 Months/1 & 2 Years)**

1. Check crosshead pin to crosshead pin bore and connecting rod bushing bore by removing crosshead pins.
2. Check for excessive wear in the auxiliary end drive chain tightener.
3. Check for excessive ring groove wear in pistons.

## Every 6 Years or 48,000 hours (plus Daily/Monthly/6 Months/1, 2 & 4 Years)

1. Replace lubricator distribution blocks.
2. Replace crosshead bushings.

## Trouble Shooting

Minor problems can be expected during the routine operation of an Ariel compressor. These troubles are most often traced to liquid, dirt, improper adjustment or to operating personnel being unfamiliar with Ariel compressors. Difficulties of this type can usually be corrected by cleaning, proper adjustment, elimination of an adverse condition, replacement of a relatively minor part or proper training of the operating personnel.

Major problems can usually be traced to long periods of operation with unsuitable lubrication, careless operation, lack of routine maintenance or the use of the compressor for purposes for which it was not intended.

Recording of the interstage pressures and temperatures on multistage units is valuable because any variation, when operating at a given load point, indicates trouble in one of the stages. Normally, if the interstage pressure drops the trouble is in the lower pressure cylinder. If it rises, the problem is normally in the higher pressure cylinder.

While it would be impossible to compile a complete list of every possible problem, listed below are some of the more common ones with their possible causes.

Problem	Possible Causes
Low Oil Pressure	Oil pump failure. Oil foaming, as shown in sight glass, from counterweights striking oil surface (oil level too high) or from vortex at strainer inlet (oil level too low) or leaks in pump suction line. Cold oil. Dirty oil filter. Interior frame oil leaks. Excessive leakage at bearings. Improper low oil pressure switch setting. Oil pump relief valve set too low. Defective pressure gauge. Plugged oil sump strainer. Improper end clearance in oil pump.
Noise in Cylinder	Loose piston. Piston hitting cylinder head end head or crank end head. Loose crosshead balance nut. Broken or leaking valve(s). Worn or broken piston rings or wear bands. Valve improperly seated or damaged gasket seat. Liquids in cylinder.

Problem	Possible Causes
Excessive Packing Leakage	<ul style="list-style-type: none"> <li>Worn packing rings.</li> <li>Improper lube oil and or insufficient lube rate.</li> <li>Dirt in packing.</li> <li>Packing rings assembled incorrectly.</li> <li>Improper ring side or end gap clearance.</li> <li>Plugged packing vent system.</li> <li>Scored, tapered or out of round piston rod.</li> <li>Excessive piston rod run-out.</li> <li>Packing not seated or properly run in.</li> </ul>
Packing Over Heating	<ul style="list-style-type: none"> <li>Lubrication failure.</li> <li>Improper lube oil and/or insufficient lube rate.</li> <li>Worn packing rings.</li> <li>Dirt in packing.</li> <li>Improper ring side or end gap clearance.</li> <li>Scored, tapered or out of round piston rod.</li> <li>Excessive piston rod runout.</li> </ul>
Excessive Carbon on Valves	<ul style="list-style-type: none"> <li>Excessive lube oil.</li> <li>Improper lube oil.</li> <li>Oil carry-over from inlet system or previous stage.</li> <li>Broken or leaking valves causing high temperature.</li> <li>Excessive temperature due to high pressure ratio across cylinders.</li> </ul>
Relief Valve Popping	<ul style="list-style-type: none"> <li>Faulty relief valve.</li> <li>Leaking suction valves or rings on next higher stage.</li> <li>Obstruction, bind or valve closed in discharge line.</li> </ul>
High Discharge Temperature	<ul style="list-style-type: none"> <li>Excessive ratio across cylinder due to leaking inlet valves or rings on next higher stage.</li> <li>Fouled intercooler piping.</li> <li>Leaking discharge valves or piston rings.</li> <li>High inlet temperature.</li> <li>Improper lube oil and or lube rate.</li> </ul>
Frame Knocks	<ul style="list-style-type: none"> <li>Loose crosshead pin or pin caps.</li> <li>Loose or worn main, crankpin or crosshead bearings.</li> <li>Low oil pressure.</li> <li>Cold oil.</li> <li>Incorrect oil.</li> <li>Knock is actually from cylinder end.</li> <li>Low fluid level in damper.</li> </ul>
Drive End of Crankshaft Oil Leak	<ul style="list-style-type: none"> <li>Clogged vent or vent piping.</li> <li>Excessive cylinder packing leakage.</li> </ul>
Piston Rod Oil Wiper Leaks	<ul style="list-style-type: none"> <li>Worn wiper rings.</li> <li>Wipers incorrectly assembled.</li> <li>Worn/scored rod.</li> <li>Improper fit of rings to rod/side clearance.</li> </ul>

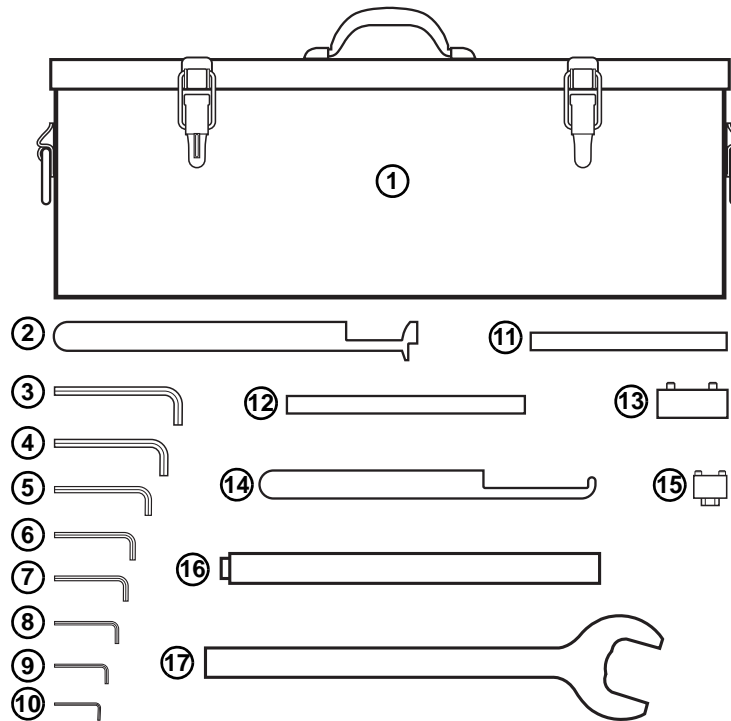
## **SECTION 7 - APPENDICES**

### **Ariel Tools**

#### **Ariel Furnished Tools**

Ariel provides Tool Kit G-0038 with every JGI:M:N:P:Q compressor. It contains the tools shown in the figure below. These tools are specifically designed for use on Ariel compressors. Clean all tools before use and verify full tool engagement with the part being removed or installed. If the Tool Kit is missing or if a tool is missing, worn, or broken, call your Ariel

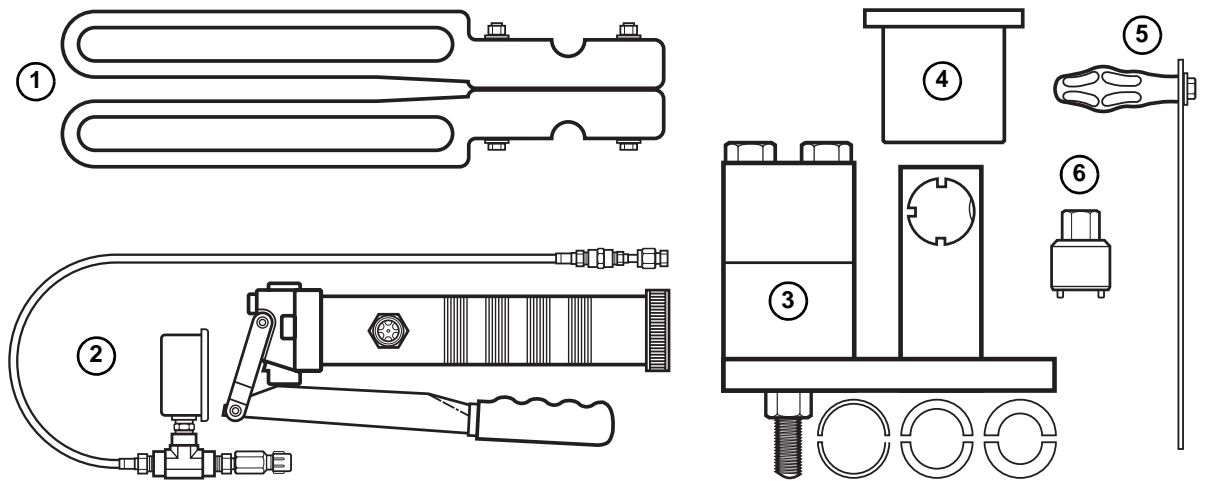
distributor for a replacement. Do not use worn or broken tools, or substitutes for Ariel furnished tools.



1. Tool Box, A-0798.
2. Crank End Clearance Setting Tool, 0.035 in. (0.89 mm), A-13801. Provided only for 2-3/4M, 3M, 2-3/4P-CE, and 3-1/4P-CE class cylinders.
3. 3/8 in. Allen Wrenches, Long Arm, 2 provided.
4. 5/16 in. Allen Wrenches, Short Arm, 3 provided.
5. 1/4 in. Allen wrench, Short Arm, 3 provided.
6. 3/16 in. Allen Wrenches, Short Arm, 5 provided.
7. 5/32 in. Allen Wrenches, Short Arm, 5 provided
8. 9/64 in. Allen Wrenches, Short Arm, 1 provided.
9. 1/8 in. Allen Wrenches, Short Arm, 10 provided.
10. 3/32 in. Allen Wrenches, Short Arm, 10 provided.
11. Valve Puller Tool, 5/16 x 1/2 in. UNF, A-0135.
12. Valve Puller Tool, 1/4 x 3/8 in. UNF, A-0409.
13. Piston Turning/Piston Nut Torquing Tool, A-0279, for 3/4 in. square drive wrench.
14. Crank End Clearance Setting Tool, 0.035 in. (0.89 mm), A-11344. Provided only for 2-1/4P-CE class cylinders.
15. Piston Turning Tool, A-1678, for 9/16 in. socket, provided only with small tandem cylinders.
16. Peg Wrench for Round Crosshead-Balance Nuts, 3/4 in. Diameter, A-0076.
17. Open End Wrench for Hex Crosshead-Balance Nuts, 2 in., B-0016.
18. Piston Entering Sleeve, provided only with compressors cylinders with step to bore. See Ariel Parts Book for part number, not shown.
19. Piston Rod Entering Sleeve A-8561, not shown.
20. Fastener Tightening Torque Chart, ER-63, not shown.

**FIGURE 7-1 ARIEL FURNISHED TOOLS**

## Ariel Tools - Purchased Separately From Authorized Dealer



1. Ratchet-Wrench-Extension Support for turning the piston and rod assembly, B-1240. Shown assembled for storage in tool box. Useful for large bore cylinders.
2. Force Feed Lubrication System Purge Gun (Hand Pump Kit), G-7162.
3. Piston and Rod Clamping Fixture, D-0961.
4. Piston Rod Entering Sleeve G-7194.
5. Main-Bearing Plastic Removal Tool, G-10706.
6. Force Feed Lubricator Bearing-Housing (left hand thread) Spanner Wrench, A-8158. 1" hex.

**FIGURE 7-2 PURCHASED SEPARATELY TOOLS**

## Minimum Hand & Commercial Tools Required

The following standard tools are normally all that is required to work on Ariel reciprocating compressors. These tools are in addition to the Ariel furnished and optional tools listed above. Acquiring high-quality tools and user-friendly, secure tool storage facilities are cost effective. Please contact Ariel if you have questions about tools on Ariel units.

- Tool boxes for hand tools.
- 15 - 18 in. Adjustable Wrench (Crescent Type).
- Combination Open/Boxed End Wrench Set - including sizes up through 1-1/8 in.
- Screw Driver Set, Flat and Phillips - including 2 - Medium; 1 - Extra Large; 1 - Extra Long Sizes.
- Forged Steel Punch and Chisel Set, including a 60° Center Punch.
- 3/8 in. Square Drive Wrench Set, including:
  1. 12 Point Socket Set w/ Breaker Bar, Ratchet, Speed Wrench, Extensions.
  2. Universal Joint, Impact Type (Ball).
  3. Adapter to 1/2 in. Drive.
  4. 12 Point Box-End "Torque Adapter" Extension Wrench Set, including 1/2 & 5/8 in. sizes, for tandem forged steel cylinder mounting bolts on smaller frame sizes.
  5. Calibrated Torque Wrench, 10 Lb-In to 250 Lb-In (1 to 30 N·m) range.
- 1/2 in. Square Drive Wrench Set, including:
  1. 12 Point Socket Set w/ Breaker Bar, Ratchet, Speed Wrench, Extensions.
  2. Universal Joint, Impact Style (Ball).



3. Adapters to 3/8 in. and 3/4 in. Drive.
  4. 1-1/4 and 1-5/8 in. Open End Crowfoot "Torque Adapter" Extension Wrenches.
  5. 1-1/2 and 2-1/4 in. boxed end "Torque Adapter" Extension Wrenches.
  6. 1/4, 1/2, and 5/8 in. Hex Key (Allen) Socket.
  7. Calibrated Torque Wrench, 50 LB-FT to 250 LB-FT (65 to 350 N·m) range, for use with right and left hand threads.
- 3/4 in. Square Drive Wrench Set, including:
    1. 12 Point Socket Set w/ Breaker Bar, Ratchet, Extensions.
    2. Adapters to 1/2" and 1" Drive.
    3. Calibrated Torque Wrench to 600 LB-FT (800 N·m) range.
  - 1 in. Square Drive Wrench set, including:
    1. 12 Point Socket Set (w/ Sockets up through 2-5/8 in.).
    2. Calibrated Torque Wrench to 1000 Lb-Ft (1400 N·m) range.
  - Two (2) Dead Blow Semi-Soft Faced Hammers, Primarily for Slugging the Cross-head-Balance Nut Wrench, approximately 100 ounce or 6 lb (3 kg) for JGC:D frames and 56 ounce or 3.5 lb (1.5 kg) for smaller frames.
  - Long Blade Feeler Gage Pack in Assorted Thickness'.
  - Pry Bar - 3 feet (1 m) Long.
  - Hexagon Allen-Type Key-Wrenches (to ANSI/ASTM B18.3) for Piston-Nut Set-Screws. Two Hex Wrenches are Consumed (Destroyed) with each Tightening of a Piston Nut. A quantity of hex wrenches needs to be kept on hand, considering the consumption during maintenance. Hex Allen-type-wrench sizes for piston-nut set-screws - nominal inch sizes:
    1. JG:A:M:N:P:Q:I 3/32
    2. JGR:J:W:B:V:KBB:V 1/8
    3. JGH:E:K:T 5/32
    4. JGC:D:Z:U 3/16
  - Tape Measure.
  - Flashlight.
  - Small Mirror on a Flexible Extension Rod.
  - Small Magnet on a Flexible Extension Rod.
  - Small Gas Torch.
  - Electric and/or Pneumatic Drill
  - Twist Drill Set
  - Machinist scale with 0.01 inch or 0.5 mm increments.
  - Calibrated Button and Needle type Dial Indicators with 0.0005 inches (0.005 mm) increments, magnetic stands and mounting hardware.
  - Torque Multiplier and/or Hydraulic Torque Wrench for larger frame sizes.

TABLE 7-1: SI METRIC CONVERSION

MEASUREMENT	CONVERSION
Area	<ul style="list-style-type: none"> <li>square inch or <math>\text{in}^2 \times 0.00064516 = \text{meter}^2</math> or <math>\text{m}^2</math></li> <li>square inch or <math>\text{in}^2 \times 6.4516 = \text{centimeter}^2</math> or <math>\text{cm}^2</math></li> </ul>
Flow - Gas	<ul style="list-style-type: none"> <li>Million standard cubic feet/day or MMSCFD (at 14.696 psia &amp; 60°F) <math>\times 0.310 = \text{normal meter}^3/\text{second}</math> (at 1.01325 bar &amp; 0°C), or <math>\text{m}^3/\text{s}_n</math></li> <li>Standard cubic feet/minute or SCFM (at 14.696 psia &amp; 60°F) <math>\times 1.607 = \text{normal meter}^3/\text{hour}</math> (at 1.01325 bar &amp; 0°C), or <math>\text{m}^3/\text{h}_n</math></li> </ul>
Flow - Liquid	<ul style="list-style-type: none"> <li>US gallons per minute or GPM <math>\times 0.0630902 = \text{liter/second}</math> or <math>\text{L/s} = \text{dm}^3/\text{s}</math></li> <li>US gallons per minute or GPM <math>\times 0.227125 = \text{meter}^3/\text{hour}</math> or <math>\text{m}^3/\text{h}</math></li> </ul>
Force	<ul style="list-style-type: none"> <li>lbf or pound (force) <math>\times 4.44822 = \text{Newton}</math> or <math>\text{N}</math></li> </ul>
Heat	<ul style="list-style-type: none"> <li>British Thermal Units or BTU <math>\times 1.05506 = \text{kilojoule}</math> or <math>\text{kJ}</math></li> </ul>
Length	<ul style="list-style-type: none"> <li>inches or in or " <math>\times 25.4000 = \text{millimeters}</math> or <math>\text{mm}</math></li> <li>feet or ft <math>\times 0.304800 = \text{meter}</math> or <math>\text{m}</math></li> </ul>
Mass	<ul style="list-style-type: none"> <li>pound (mass) or <math>\text{lb}_m \times 0.453592 = \text{kilogram}</math> or <math>\text{kg}</math></li> </ul>
Moment or Torque	<ul style="list-style-type: none"> <li>Lb x Ft or pound-foot (force) <math>\times 1.35583 = \text{Newton-meter}</math> or <math>\text{N-m}</math></li> <li>Lb x In or pound-inch (force) <math>\times 0.112985 = \text{Newton-meter}</math> or <math>\text{N-m}</math></li> </ul>
Power (Horsepower based on 550 ft-lb/sec.)	<ul style="list-style-type: none"> <li>Horsepower or HP <math>\times 0.745700 = \text{kilowatt}</math> or <math>\text{kW}</math></li> </ul>
Pressure or Stress G or g suffix = gauge pressure; A or a = absolute; D or d = differential	<ul style="list-style-type: none"> <li>psi <math>\times 6894.757 = \text{Pascal}</math> or <math>\text{Pa}</math></li> <li>Pa <math>\times 0.000145 = \text{psi}</math></li> <li>psi <math>\times 6.894757 = \text{kiloPascal}</math> or <math>\text{kPa}</math></li> <li>kPa <math>\times 0.145 = \text{psi}</math></li> <li>bar <math>\times 100\,000 = \text{Pa}</math></li> <li>Pa <math>\times 0.00001 = \text{bar}</math></li> <li>bar <math>\times 100 = \text{kPa}</math></li> <li>kPa <math>\times 0.01 = \text{bar}</math></li> <li>psi <math>\times 68.94757 = \text{millibar}</math> or <math>\text{mbar}</math></li> <li>mbar <math>\times 0.0145 = \text{psi}</math></li> <li>psi <math>\times 0.06894757 = \text{bar}</math></li> <li>bar <math>\times 14.5 = \text{psi}</math></li> </ul>
Speed	<ul style="list-style-type: none"> <li>feet per minute or FPM <math>\times 0.005080 = \text{meter per second}</math> or <math>\text{m/s}</math></li> <li>revolutions per minute or RPM or <math>\text{r/min} \times 60 = \text{revolutions per second}</math> or <math>\text{rev/s}</math></li> </ul>
Temperature	<ul style="list-style-type: none"> <li>(degrees Fahrenheit or °F - 32) <math>\div 1.8 = \text{degrees Celsius}</math> or °C</li> </ul>
Time	<ul style="list-style-type: none"> <li>sec or s = second</li> <li>minute or min <math>\times 60 = \text{s}</math></li> <li>hour or hr or h <math>\times 60 = \text{min}</math></li> <li>h <math>\times 3600 = \text{s}</math></li> </ul>
Viscosity (Dynamic)	<ul style="list-style-type: none"> <li>Saybolt Universal seconds or SUS or SSU <math>\times 0.22 - (180 \div \text{SUS}) = \text{mm}^2/\text{s} = \text{centistoke}</math> or <math>\text{cSt}</math> (for a range of 33 through 200,000 SUS)</li> </ul>

**TABLE 7-2: USEFUL SI METRIC MULTIPLE AND SUBMULTIPLE FACTORS**

<b>FACTOR</b>	<b>PREFIX</b>	<b>SI SYMBOL (Maintain Case)</b>
1 000 000 = $10^6$	mega	M
1 000 = $10^3$	kilo	k
100 = $10^2$	hecto (not recommended)	h
10 = $10^1$	deka (not recommended)	da
0.1 = $10^{-1}$	deci (not recommended)	d
0.01 = $10^{-2}$	centi	c
0.001 = $10^{-3}$	milli	m
0.000 001 = $10^{-6}$	micro	$\mu$

## Gas Analysis Common Abbreviations

TABLE 7-3: GAS ANALYSIS COMMON ABBREVIATIONS

COMMON ABBREVIATION	COMPONENT NAME (SYNONYM)	CHEMICAL FORMULA
C1	Methane	CH <sub>4</sub>
C2	Ethane	C <sub>2</sub> H <sub>6</sub>
C3	Propane	C <sub>3</sub> H <sub>8</sub>
IC4	Iso-Butane (2-Methyl Propane)	C <sub>4</sub> H <sub>10</sub>
NC4	N-Butane	C <sub>4</sub> H <sub>10</sub>
IC5	Iso-Pentane (2-Methyl Butane)	C <sub>5</sub> H <sub>12</sub>
NC5	N-Pentane	C <sub>5</sub> H <sub>12</sub>
NEOC5	Neopentane	C <sub>5</sub> H <sub>12</sub>
NC6	Hexane	C <sub>6</sub> H <sub>14</sub>
NC7	Heptane	C <sub>7</sub> H <sub>16</sub>
NC8	Octane	C <sub>8</sub> H <sub>18</sub>
NC9	Nonane	C <sub>9</sub> H <sub>20</sub>
NC10	N-Decane	C <sub>10</sub> H <sub>22</sub>
NC11	N-Undecane (Hendecane)	C <sub>11</sub> H <sub>24</sub>
NC12	N-Dodecane	C <sub>12</sub> H <sub>26</sub>
C2-	Ethylene (Ethene)	C <sub>2</sub> H <sub>4</sub>
C3-	Propene (Propylene)	C <sub>3</sub> H <sub>6</sub>
BENZ	Benzene	C <sub>6</sub> H <sub>6</sub>
TOL	Toluene	C <sub>7</sub> H <sub>8</sub>
EBNZ	Ethylbenzene	C <sub>8</sub> H <sub>10</sub>
CO	Carbon Monoxide	CO
CO <sub>2</sub>	Carbon Dioxide	CO <sub>2</sub>
H <sub>2</sub> S	Hydrogen Sulfide	H <sub>2</sub> S
H <sub>2</sub>	Hydrogen	H <sub>2</sub>
O <sub>2</sub>	Oxygen	O <sub>2</sub>
N <sub>2</sub>	Nitrogen	N <sub>2</sub>
H <sub>2</sub> O	Water	H <sub>2</sub> O
He	Helium	He
Ar	Argon	Ar
---	Air	---

## Technical and Service Schools on Ariel Compressors

Ariel schedules several in-plant schools each year, which include classroom and hands-on training. See the Ariel Website ([www.arielcorp.com](http://www.arielcorp.com)) go to "Support" and follow the links at "Product Training" for more information and/or to register. Ariel can also send a representative to provide customized training on location. Contact Ariel for details.

## Ariel Customer Technical Bulletins

Ariel Customer Technical Bulletins provide changes, corrections and /or additions to the Technical Manual, for Packagers and End Users. Read these bulletins before operating or servicing the equipment.

For the latest editions of Ariel Customer Technical Bulletins, visit [www.arielcorp.com](http://www.arielcorp.com), or obtain copies direct from your Packager or Ariel.

To view Ariel Customer Technical Bulletins from the Ariel Web Site requires Acrobat Reader software to be installed on your computer. To get a free current version of Acrobat Reader, click Downloads/Computer Tools on the Ariel Home Page, then click the Acrobat Reader link. To view and print Ariel CTB's (with Acrobat Reader installed), click Support/Customer Technical Bulletins on the Ariel Home Page, then click on the type of equipment. To download a CTB electronic file, right click the desired CTB number, then click Save Target As... in the pop up window. After using printed or downloaded CTB's, destroy all prints and files. Seek the latest CTB information from the Ariel Web Site.

## Vendor Literature

When available, vendor literature on purchased parts used in Ariel Compressors is provided on the Ariel Website ([www.arielcorp.com](http://www.arielcorp.com)), or copies may be obtained from the Packager or from Ariel.

## Ariel Contact Information

Contact	Telephone	Fax	E-Mail
Ariel Response Center	888-397-7766	740-397-1060	<a href="mailto:arc@arielcorp.com">arc@arielcorp.com</a>
Spare Parts	(toll free USA & Canada) or 740-397-3602 (International)	740-393-5054	<a href="mailto:spareparts@arielcorp.com">spareparts@arielcorp.com</a>
Order Entry		740-397-3856	---
Ariel World Headquarters	740-397-0311	740-397-3856	<a href="mailto:info@arielcorp.com">info@arielcorp.com</a>
Technical Services			<a href="mailto:fieldservice@arielcorp.com">fieldservice@arielcorp.com</a>
Web Site: <a href="http://www.arielcorp.com">www.arielcorp.com</a>			

Ariel Response Center Technicians or Switchboard Operators answer telephones during Ariel business hours, Eastern Time - USA or after hours by voice mail. Contact an authorized distributor to purchase Ariel parts. Always provide Ariel equipment serial number(s) to order spare parts. The after-hours Telephone Emergency System works as follows:

1. Follow automated instructions to Technical Services Emergency Assistance or Spare Parts Emergency Service. Calls are answered by voice mail.
2. Leave a message: caller name and telephone number, serial number of equipment in question (frame, cylinder, unloader), and a brief description of the emergency.
3. Your voice mail routes to an on-call representative who responds as soon as possible.

**FRAME**

**THIS PAGE LEFT INTENTIONALLY BLANK**

8/01/12

ARIEL CORPORATION  
SALES ORDER COVER SHEET

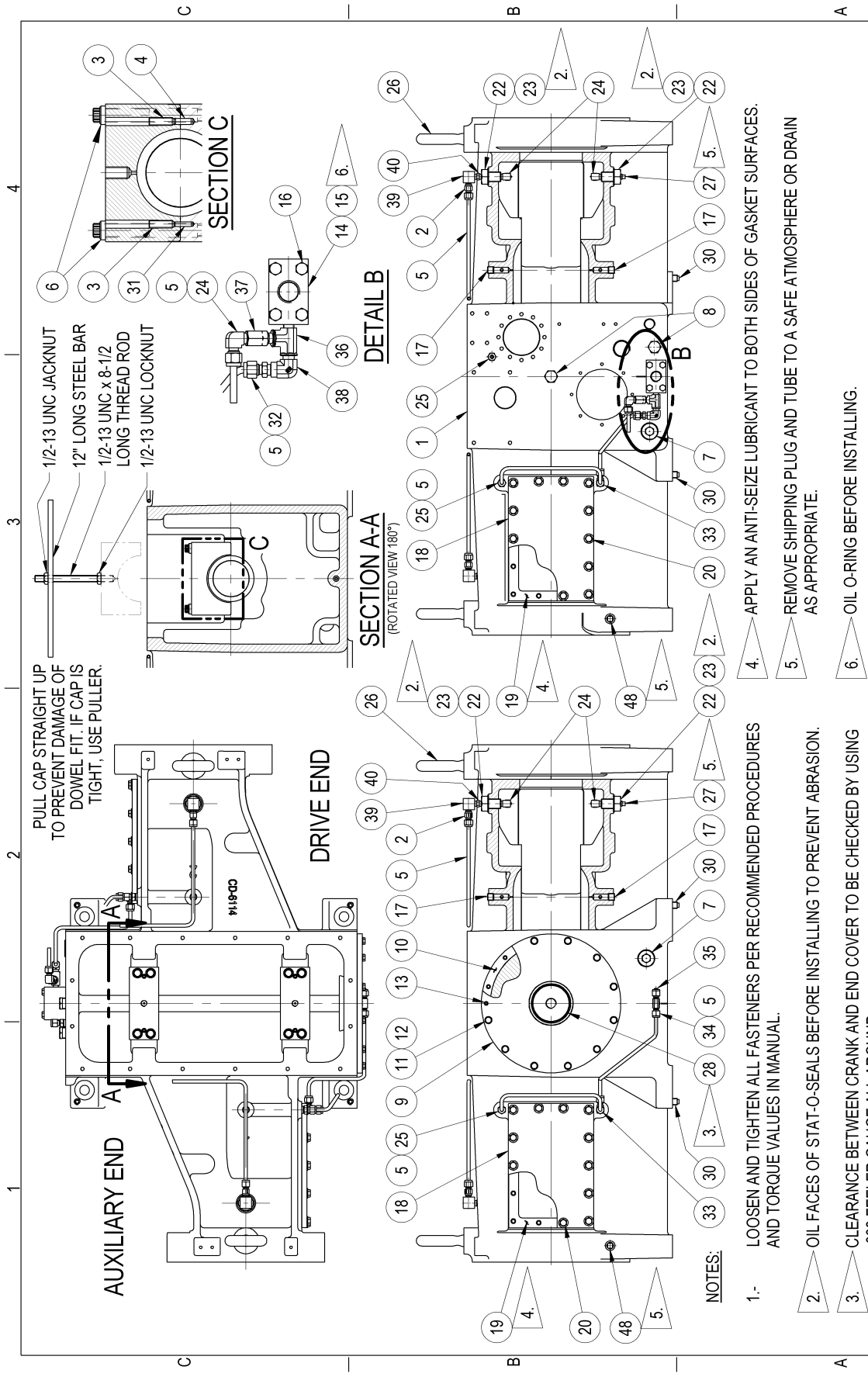
C/N: 001

RHCOVP02

SERIAL #: F-39114

PART: JGN:Q CLASS	DESCRIPTION: JGN-JGQ	FRAME CLASS	
PART NUMBER	QTY	DESCRIPTION	DRAWING NO.
G-20021	1	FRAME ASSEMBLY, JGM:N:P:Q/2	A-18920
G-5690	1	CRANKSHAFT ASSY,JGQ/2	A-6501
G-1662	2	CONN ROD FS,JG:A:N:Q,UNF THD.	A-3985
G-0154	2	CROSSHEAD ASSEMBLY, JG:A:N:Q:325JGS	A-6873
B-0015	1	XHD NUT, .7#,HEX,G:A:M:P	B-0015
D-0061	1	CROSSHEAD, MED, DI, 19.2#, JG:A:M:P:N:Q	D-0061
D-3284	1	CROSSHEAD, XLGT, DI, 8.0#, JG:A:M:P:N:Q	D-3284
L-00765	1	18T-18T-9T-6S	N.A.
G-3220	1	1"SIGHT GLASS,JGAMP:RWJ/2&ACF	N.A.
G-19674	1	LUBE OIL PUMP ASSEMBLY, JGM:P:N:Q/2	A-18552
FF LUBRICATOR A	1	FORCE FEED LUBRICATOR	A-18919 2 SHT
G-5095	1	DIST.BLK.MTG.SPACER,M:N:P:Q	N.A.
G-2706	1	RUPTURE DISC ASSEMBLY, 7300 PSI	N.A.
G-1080	2	FF TUB.TANDEM,JG:A:M:P EA CYL	N.A.
G-1079	1	FF TUBING,JG:A:M:P/2 D.A.CYLS	N.A.
G-2935	1	FORCE FEED TUBING, BOTTOM LUBE, JG:A:M:P:N:Q:R:W:J:H:E:K:T, EACH CYLINDER, STD	N.A.
G-9055	1	FORCE FEED TUBING, M=R2, W/CYL>3600	N.A.
G-0176	1	CHAIN ASSEMBLY, STANDARD OR REVERSE ROTATION, JGM:P:N:Q	A-7765
G-0173	1	TOP COVER ASSEMBLY, STANDARD AND REVERSE ROTATION, JGM:P:N:Q	A-7931
G-19557	1	FORCE FEED GAUGE ASSEMBLY, 7500 PSI, GAUGE BRACKET, 3/8 TUBE, M:N:P:Q	A-18429
G-14217	1	FF S/D,PRO-FLO-JR,DC,STD	N.A.
G-16340	1	TOOL KIT ASSY, JG:M:N:P:Q:I:S	N.A.





**ARIEL CORPORATION**  
35 BLACKJACK ROAD  
MOUNT VERNON, OHIO 43050

REV	DESCRIPTION	INITIALS	DATE

REV	DESCRIPTION	INITIALS	DATE
0	17233	EON	EON

REV	DESCRIPTION	INITIALS	DATE

REV	DESCRIPTION	INITIALS	DATE

REV	DESCRIPTION	INITIALS	DATE

ASSEMBLY DWG. NO. **A-18920**  
SCALE NONE  
SHT 1 OF 1

8/01/12

PARTS LIST

FRAME AND OIL/DUST SEAL ASSEMBLY  
JGM:P:N:Q/2

PART NO. G-20021  
REF DRAWING A-18920

ITEM	PART NUMBER	QTY	DESCRIPTION
1	D-6117	1	FRAME, JGM:P:N:Q/2
2	A-18496	2	CHECK VALVE, DOUBLE BALL, SS, 1/4 TUBE INLET X 1/8 NPT OUTLET,
3	FS0400DG	0	SET SCREW, CUP POINT, 5/16-18 X 1"
4	FP0500FE	0	DOWEL PIN, 1/4 OD X 3/4 LONG, +.0002
5	PT0200CB	153."	TUBING, SS, 1/4 OD X .035 WALL
6	FC0120GT	8	12-POINT CAPSCREW, 1/2-13 X 4-1/2, G8
7	PP0850KB	2	PIPE PLUG,1"NPTF,HEX SOC,STL
8	PP0810GB	2	PIPE PLUG, HEX HEAD, 1/2 NPT, STL
9	C-0080	1	SHAFT SEAL HOUSING,JGM:P:N:Q
10	A-0194	1	FIBER GASKET,10.625 OD X 09.265 ID X .031,OIL SEAL JGM:P:N:Q
11	FC0102CF	12	HEX HEAD CAPSCREW, 1/4-20 X 7/8, G5
12	FW0501BA	12	FLAT WASHER, 1/4 I.D. PLAIN
13	FP0505FG	1	ROLL PIN, 1/4 OD X 1" LONG
14	A-0147	1	END PLATE, OIL GALLERY, JG:A/2:4
15	A-0009	1	O-RING, VT, 1.387 OD X .139, 75/85 DUROMETER
16	FC0102CK	4	HEX HEAD CAPSCREW, 1/4-20 X 2, G5
17	PP0850CB	4	PIPE PLUG,1/4NPTF,HEX SOC,STL
18	A-0066	2	COVER, GUIDE, JG:M:P:A:S
19	A-0067	2	FIBER GASKET,09.500 X 06.438 X .031,GUIDE COVER JG:M:P
20	A-10185	28	SEMS BOLT, 5/16-18 X 1", G5
22	A-0101	4	LUBE FITTING, 3/4-10 X 1
23	FW0550IA	4	STAT-O-SEAL, 3/4 DIA., NITRILE

WHEN A ZERO APPEARS IN THE QUANTITY COLUMN IT  
DOES NOT REPRESENT THE QUANTITY REQUIRED.

\*\*\* ALWAYS PROVIDE SERIAL NUMBER WHEN ORDERING SPARE PARTS. \*\*\*



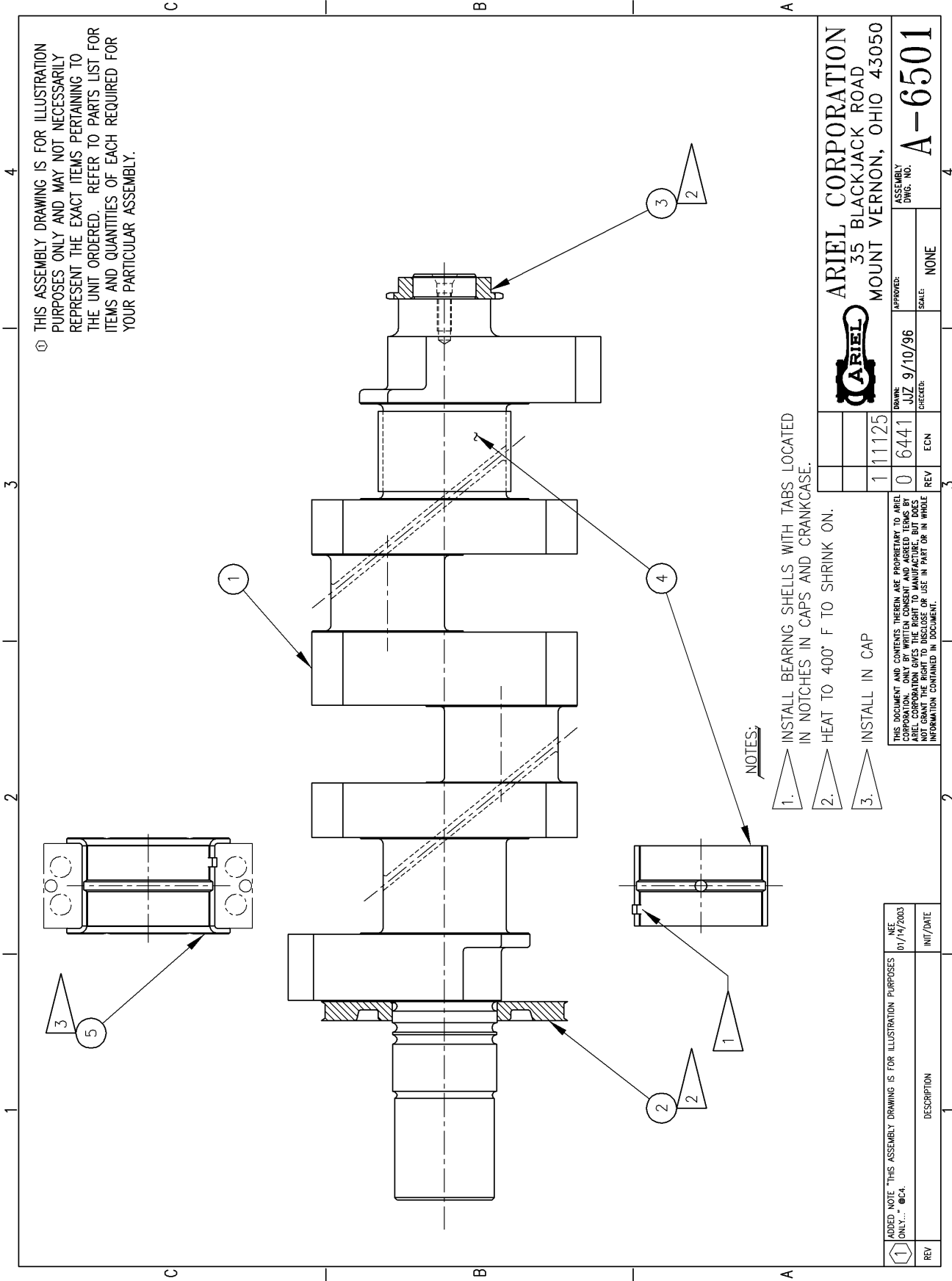
8/01/12

PARTS LIST

24	A-0815	5	MALE ELBOW, STL, 1/4 TUBE X 1/8 NPT
25	A-0827	3	MALE CONNECTOR, STL, 1/4 TUBE X 1/4 NPT
26	A-3881	2	EYEBOLT, 7/8-9 UNC
27	A-15842	2	PIPE PLUG, 1/8NPT, SQUARE HEAD, STL, DRILLED
28	A-0245	1	DUST SEAL, TFE, JG:A:M:P:N:Q
30	FS0401GH	4	SET SCREW, HALF DOG POINT, 1/2-13 X 1-1/4
31	FP0500EE	0	DOWEL PIN, 3/16 OD X 3/4 LONG, +.0002
32	A-0830	1	MALE CONNECTOR, STL, 1/4 TUBE X 1/8 NPT
33	A-0856	2	MALE RUN TEE, STL, 1/4 TUBE X 1/4 NPT
34	A-0808	1	MALE BRANCH TEE, STL, 1/4 TUBE X 1/4 NPT
35	A-0918	1	PLUG, TUBE FITTING, STL, 1/4 TUBE
36	A-15556	1	STREET TEE, STL, 1/8P
37	A-3763	1	CHK VLV, 1/8MX1/8F, SS, PPT/14PSI
38	A-0804	1	STREET ELBOW, 90° 1/2", 1/8 NPT, STL
39	A-17774	2	OIL TRAP, BODY, SS, 1/8 NPT
40	A-17775	2	OIL TRAP, STEM, SS, 1/8 NPT
48	A-12569	2	PIPE PLUG, 1/4NPT, SQUARE HEAD, STL, DRILLED

WHEN A ZERO APPEARS IN THE QUANTITY COLUMN IT  
DOES NOT REPRESENT THE QUANTITY REQUIRED.

\*\*\* ALWAYS PROVIDE SERIAL NUMBER WHEN ORDERING SPARE PARTS. \*\*\*



① THIS ASSEMBLY DRAWING IS FOR ILLUSTRATION PURPOSES ONLY AND MAY NOT NECESSARILY REPRESENT THE EXACT ITEMS PERTAINING TO THE UNIT ORDERED. REFER TO PARTS LIST FOR ITEMS AND QUANTITIES OF EACH REQUIRED FOR YOUR PARTICULAR ASSEMBLY.

**NOTES:**

- 1. INSTALL BEARING SHELLS WITH TABS LOCATED IN NOTCHES IN CAPS AND CRANKCASE.
- 2. HEAT TO 400° F TO SHRINK ON.
- 3. INSTALL IN CAP

①	ADDED NOTE "THIS ASSEMBLY DRAWING IS FOR ILLUSTRATION PURPOSES ONLY..." 004.	REV
	DESCRIPTION	
	INIT/DATE	
	REV	

THIS DOCUMENT AND CONTENTS THEREIN ARE PROPRIETARY TO ARIEL CORPORATION. ONLY BY WRITTEN CONSENT AND AGREED TERMS BY ARIEL CORPORATION WILL ANY INFORMATION BE DISCLOSED OR IN WHOLE OR IN PART BE REPRODUCED OR USED FOR ANY PURPOSES NOT GRANTING THE RIGHT TO DISCLOSE OR USE IN PART OR IN WHOLE INFORMATION CONTAINED IN DOCUMENT.

1	11125	REV
0	6441	ECN
		CHECKER
	JJZ 9/10/96	SCALE
		APPROVER

**ARIEL CORPORATION**  
 35 BLACKJACK ROAD  
 MOUNT VERNON, OHIO 43050

ASSEMBLY DWG. NO. **A-6501**

4 3 2 1 1 2 3 4

8/01/12

PARTS LIST

CRANKSHAFT AND MAIN BEARINGS, NO KEY WAY      PART NO. G-5690  
JGQ/2, 3" STROKE      REF DRAWING A-6501

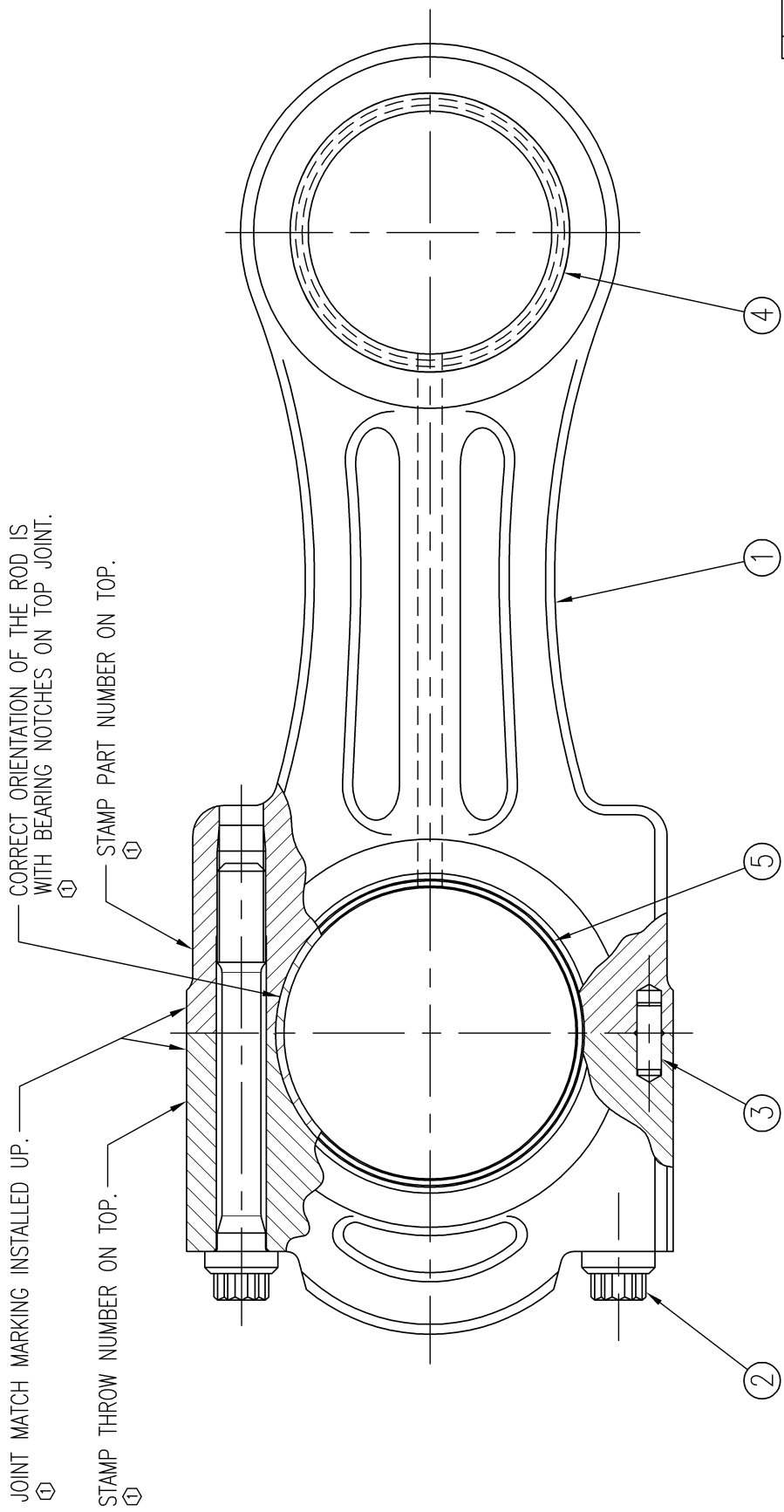
ITEM	PART NUMBER	QTY	DESCRIPTION
1	AD-1972	1	CRANKSHAFT ASSEMBLY, FS, NO KEYWAY, JGA:Q:P/2
2	B-0004	0	OIL SLINGER, JG:A:M:P:Q:N
3	A-0003	0	SPKT, 35-1 X 24T
4	B-0024	3	SLEEVE BEARING, HALF SHELL, MAIN, JG:M:P:S
5	B-0025	1	SLEEVE BEARING, HALF SHELL, THRUST, JG:A:M:P:N:Q:S
99	AD-1972-C	0	CRANKSHAFT ASSEMBLY WITH CRATE, JGA:Q:P/2

WHEN A ZERO APPEARS IN THE QUANTITY COLUMN IT  
DOES NOT REPRESENT THE QUANTITY REQUIRED.

\*\*\* ALWAYS PROVIDE SERIAL NUMBER WHEN ORDERING SPARE PARTS. \*\*\*

NOTES

1. LOOSEN OR TIGHTEN ALL FASTENERS PER RECOMMENDED PROCEDURES AND TORQUE VALUES IN MANUAL.
2. PRESS BRONZE BUSHING IN WHILE MAINTAINING ALIGNMENT OF OIL HOLE TO OIL PASSAGE IN ROD.
3. INSTALL BEARING SHELLS WITH TABS LOCATED IN NOTCHES IN ROD AND ROD CAP.



116756  
04734

**ARIEL CORPORATION**  
35 BLACKJACK ROAD  
MOUNT VERNON, OHIO 43050

**ASSEMBLY**  
DWG. No. **A-3985**

REV	DESCRIPTION
①	ADDED NOTES: "JOINT MATCH MARKING INSTALLED UP", "STAMP THROW NUMBER ON TOP", "STAMP PART NUMBER ON TOP", AND "CORRECT ORIENTATION OF THE ROD IS WITH BEARING NOTCHES ON TOP JOINT".

8/01/12

PARTS LIST

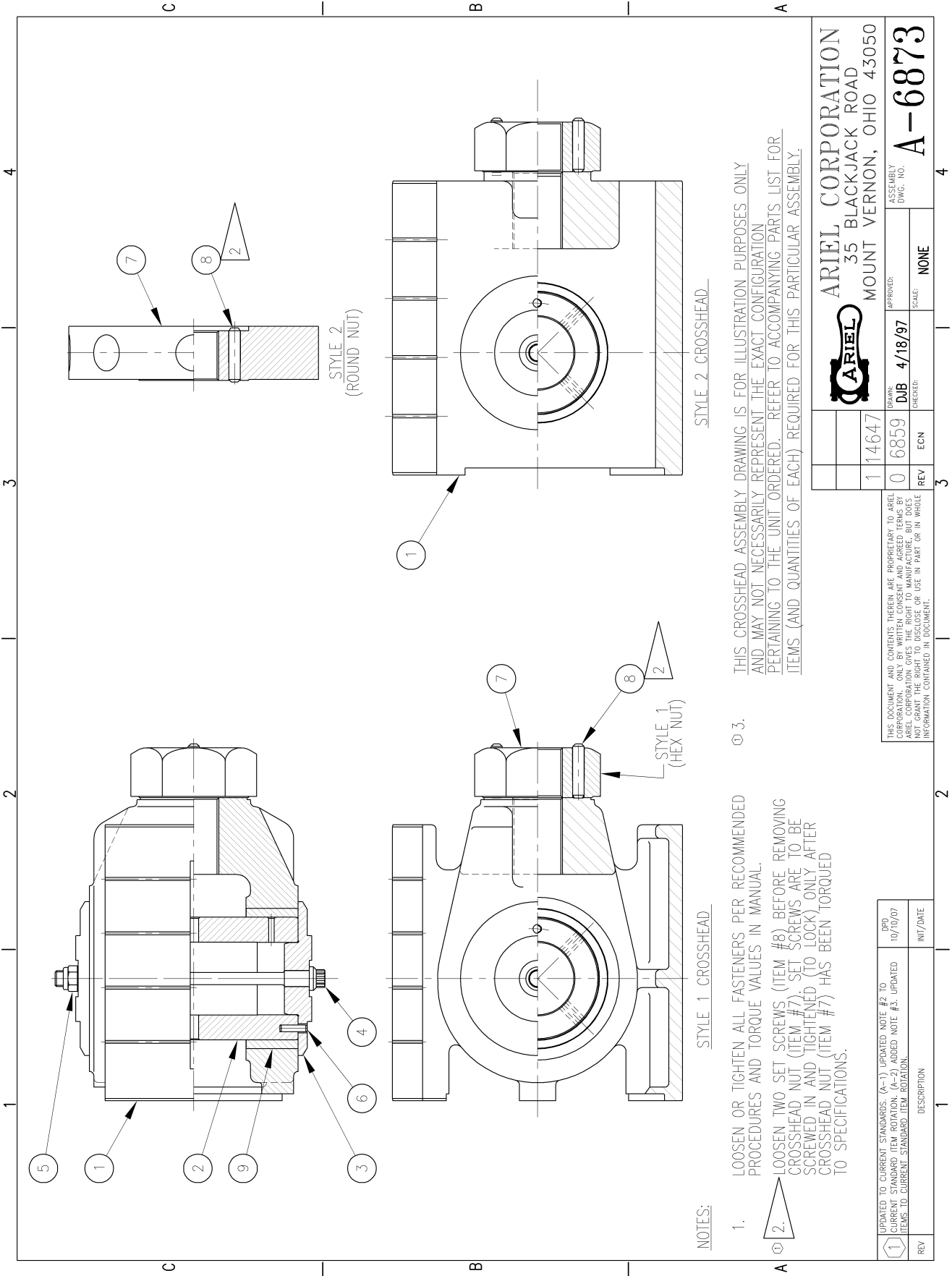
CONNECTING ROD, FORGED STEEL, UNF THREAD      PART NO. G-1662  
JG:A:N:Q, 325JGS      REF DRAWING A-3985

ITEM	PART NUMBER	QTY	DESCRIPTION
1	AD-1043	1	CONNECTING ROD ASSEMBLY, FS, UNF, JG:A:N:Q:325JGS
2	A-2120	0	12-POINT CAPSCREW, 1/2-20 X 4, G8
3	FP0500FE	0	DOWEL PIN, 1/4 OD X 3/4 LONG, +.0002
4	B-0003	0	BUSHING, CONNECTING ROD, BZ, JG:A:M:P:S:I
5	B-0023	2	SLEEVE BEARING, HALF SHELL, CONNECTING ROD, JG:A:M:P:N:Q:I:S

WHEN A ZERO APPEARS IN THE QUANTITY COLUMN IT  
DOES NOT REPRESENT THE QUANTITY REQUIRED.

\*\*\* ALWAYS PROVIDE SERIAL NUMBER WHEN ORDERING SPARE PARTS. \*\*\*





NOTES:

1. LOOSEN OR TIGHTEN ALL FASTENERS PER RECOMMENDED PROCEDURES AND TORQUE VALUES IN MANUAL.
2. LOOSEN TWO SET SCREWS (ITEM #8) BEFORE REMOVING CROSSHEAD NUT (ITEM #7). SET SCREWS ARE TO BE SCREWED IN AND TIGHTENED (TO LOCK) ONLY AFTER CROSSHEAD NUT (ITEM #7) HAS BEEN TORQUED TO SPECIFICATIONS.
3. THIS CROSSHEAD ASSEMBLY DRAWING IS FOR ILLUSTRATION PURPOSES ONLY AND MAY NOT NECESSARILY REPRESENT THE EXACT CONFIGURATION PERTAINING TO THE UNIT ORDERED. REFER TO ACCOMPANYING PARTS LIST FOR ITEMS (AND QUANTITIES OF EACH) REQUIRED FOR THIS PARTICULAR ASSEMBLY.

STYLE 1 CROSSHEAD

STYLE 2 CROSSHEAD

		<b>ARIEL CORPORATION</b> 35 BLACKJACK ROAD MOUNT VERNON, OHIO 43050	
APPROVED:	SCALE: NONE	ASSEMBLY DWG. NO.	A-6873
DRAWN: DJB	CHECKED: DJB	4/18/97	
1	14647	REV	3
0	6859	ECN	3

THIS DOCUMENT AND CONTENTS THEREIN ARE PROPRIETARY TO ARIEL CORPORATION. ONLY BY WRITTEN CONSENT AND AGREED TERMS BY ARIEL CORPORATION WILL ANY INFORMATION BE DISCLOSED OR IN WHOLE OR IN PART GRANT THE RIGHT TO DISCLOSE OR USE IN PART OR IN WHOLE INFORMATION CONTAINED IN DOCUMENT.

REV	DESCRIPTION	INIT/DATE
1	UPDATED TO CURRENT STANDARDS: (A-1) UPDATED NOTE #2 TO CURRENT STANDARD ITEM ROTATION. (A-2) ADDED NOTE #3. UPDATED ITEMS TO CURRENT STANDARD ITEM ROTATION.	DPB 10/10/07

8/01/12

PARTS LIST

CROSSHEAD, PIN AND BALANCE NUT  
JG:A:N:Q, 325JGS

PART NO. G-0154  
REF DRAWING A-6873

ITEM	PART NUMBER	QTY	DESCRIPTION
1	CROSSHEAD	0	FOR PART NO. SEE COVER SHEET
1	D-0060	0	CROSSHEAD, LGT, DI, 11.5#, JG:A:M:P:N:Q
1	D-0061	0	CROSSHEAD, MED, DI, 19.2#, JG:A:M:P:N:Q
1	D-0089	0	CROSSHEAD, HVY, BZ, 24.2#, JG:A:M:P:N:Q
1	D-2979	0	CROSSHEAD, HVY, BZ, 26.7#, JG:A:M:P:N:Q
1	D-3284	0	CROSSHEAD, XLGT, DI, 8.0#, JG:A:M:P:N:Q
2	A-0060	1	CROSSHEAD PIN, JG:A:M:P:I:S
3	A-0061	2	END PLATE, CROSSHEAD PIN, JG:A:M:P:N:Q
4	A-0059	1	12-POINT CAPSCREW, 3/8-24 X 5, SPECIAL
5	FN0461EA	1	SELF-LOCK NUT,ESNA,3/8-24
6	FP0505CE	2	ROLL PIN, 1/8 OD X 3/4 LONG
7	A-0051	0	CROSSHEAD NUT, 2.7#, ROUND, JG:A:M:P
7	A-0052	0	XHD NUT,4.7#,RND,G:A:M:P
7	A-0053	0	XHD NUT,6.7#,RND,G:A:M:P
7	A-0377	0	XHD NUT,8.7#,RND,G:A:M:P
7	A-3886	0	XHD NUT,10.0#,RND,G:A:MP
7	B-0015	0	XHD NUT, .7#,HEX,G:A:M:P
7	CROSSHEAD NUT	0	FOR PART NO. SEE COVER SHEET
8	FS0455CG	0	SET SCREW, CUP POINT, NYLON PATCH, 1/4-28 X 1"
9	B-0002	0	BUSHING, CROSSHEAD, BZ, JG:A:N:Q

WHEN A ZERO APPEARS IN THE QUANTITY COLUMN IT  
DOES NOT REPRESENT THE QUANTITY REQUIRED.

\*\*\* ALWAYS PROVIDE SERIAL NUMBER WHEN ORDERING SPARE PARTS. \*\*\*



8/01/12

PARTS LIST

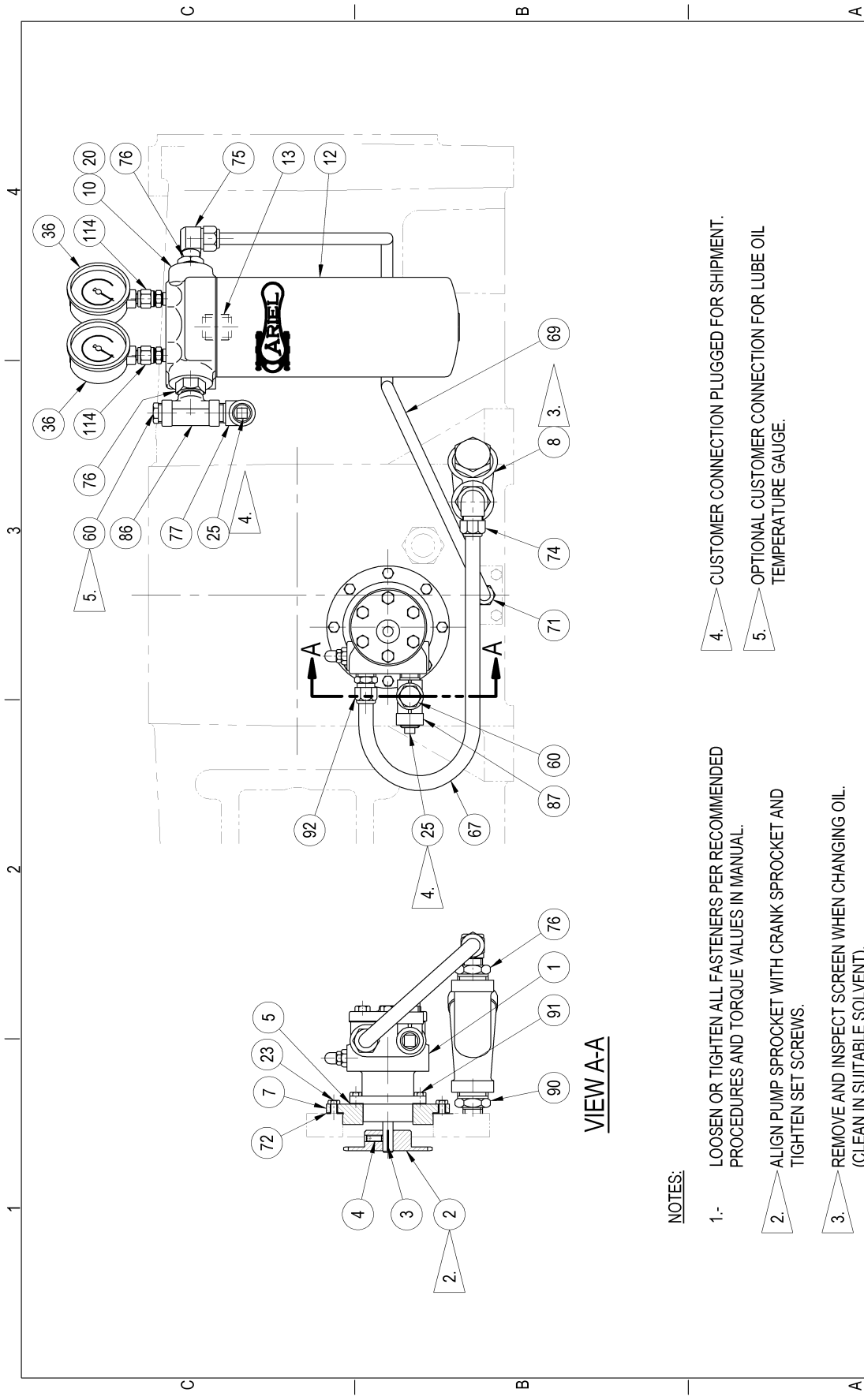
CRANKCASE LUBE OIL LEVEL SIGHT GLASS  
JG:A, JGM:P, JGR:W & JGJ/2

PART NO. G-3220  
REF DRAWING N.A.

ITEM	PART NUMBER	QTY	DESCRIPTION
1	A-0077	1	SIGHT GLASS,1" NPT

WHEN A ZERO APPEARS IN THE QUANTITY COLUMN IT  
DOES NOT REPRESENT THE QUANTITY REQUIRED.

\*\*\* ALWAYS PROVIDE SERIAL NUMBER WHEN ORDERING SPARE PARTS. \*\*\*



**VIEW A-A**

**NOTES:**

- 1.- LOOSEN OR TIGHTEN ALL FASTENERS PER RECOMMENDED PROCEDURES AND TORQUE VALUES IN MANUAL.
- 2. ALIGN PUMP SPROCKET WITH CRANK SPROCKET AND TIGHTEN SET SCREWS.
- 3. REMOVE AND INSPECT SCREEN WHEN CHANGING OIL. (CLEAN IN SUITABLE SOLVENT).
- 4. CUSTOMER CONNECTION PLUGGED FOR SHIPMENT.
- 5. OPTIONAL CUSTOMER CONNECTION FOR LUBE OIL TEMPERATURE GAUGE.

**ARIEL CORPORATION**  
 35 BLACKJACK ROAD  
 MOUNT VERNON, OHIO 43050

**ARIEL**

ASSEMBLY  
 DWG. NO. **A-18552**  
 SHT 1 OF 1

REV	DESCRIPTION	INITIATE	DATE

REV		REV		REV		REV	



THIS DOCUMENT AND CONTENTS THEREIN ARE PROPRIETARY TO ARIEL CORPORATION. ONLY BY WRITTEN CONSENT AND AGREED TERMS BY ARIEL CORPORATION GIVES THE RIGHT TO REPRODUCE OR USE IN PART OR IN WHOLE INFORMATION CONTAINED IN DOCUMENT.

8/01/12

PARTS LIST

LUBE OIL PUMP, STRAINER, FILTER  
JGM/2, JGP/2, JGN/2, JGQ/2

PART NO. G-19674  
REF DRAWING A-18552

ITEM	PART NUMBER	QTY	DESCRIPTION
1	C-0084	1	LUBE OIL PUMP, M:P:N:Q:I:JG:A/2, THL
2	A-0002	1	SPROCKET, 35-1 X 30T
3	FK0360AA	1	WOODRUFF KEY, #204, 1/2 OD X 1/16 WIDE
4	FS0455CE	1	SET SCREW, CUP POINT, NYLON PATCH, 1/4-28 X 3/4
5	A-0073	1	FIBER GASKET, .031, TUTHILL OIL PUMP
7	B-0029	1	ADAPTER, LUBE OIL PUMP, TUTHILL, JG:A/2
8	A-8247	1	LUBE OIL STRAINER, 3/4 NPT
10	C-0394	1	LUBE OIL FILTER HEAD, SINGLE L/R
12	A-0661	1	SPIN-ON FILTER, LUBE OIL
13	A-0660	0	STUD, LUBE OIL SPIN-ON FILTER
20	FC0102EG	2	HEX HEAD CAPSCREW, 3/8-16 X 1", G5
23	FC0102CF	8	HEX HEAD CAPSCREW, 1/4-20 X 7/8, G5
25	A-15683	2	PIPE PLUG, 1/2NPT, SQUARE HEAD, STL, DRILLED
36	A-18450	2	GAUGE, 100PSI, BOTTOM MOUNT, 3/8 TUBE
60	PP0810GB	2	PIPE PLUG, HEX HEAD, 1/2 NPT, STL
67	PT0200GC	24."	SS,TUBING, 5/8 OD X .049 WALL
69	PT0200FB	54."	SS,TUBING, 1/2 OD X .035 WALL
71	A-0857	1	MALE CONNECTOR, STL, 1/2 TUBE X 1/2 NPT
72	A-0068	1	FIBER GASKET,05.250 OD X 03.875 ID X .031, LUBE OIL PUMP MOUNTING, JG/2:M:P
74	A-0860	1	MALE ELBOW, STL, 5/8 TUBE X 1/2 NPT
75	A-0901	1	MALE ELBOW,STL, 1/2T X 1/2P
76	A-0844	3	HEX REDUCING BUSHING, STL, 3/4 NPT(MALE) X 1/2 NPT(FEMALE)

WHEN A ZERO APPEARS IN THE QUANTITY COLUMN IT  
DOES NOT REPRESENT THE QUANTITY REQUIRED.

\*\*\* ALWAYS PROVIDE SERIAL NUMBER WHEN ORDERING SPARE PARTS. \*\*\*



8/01/12

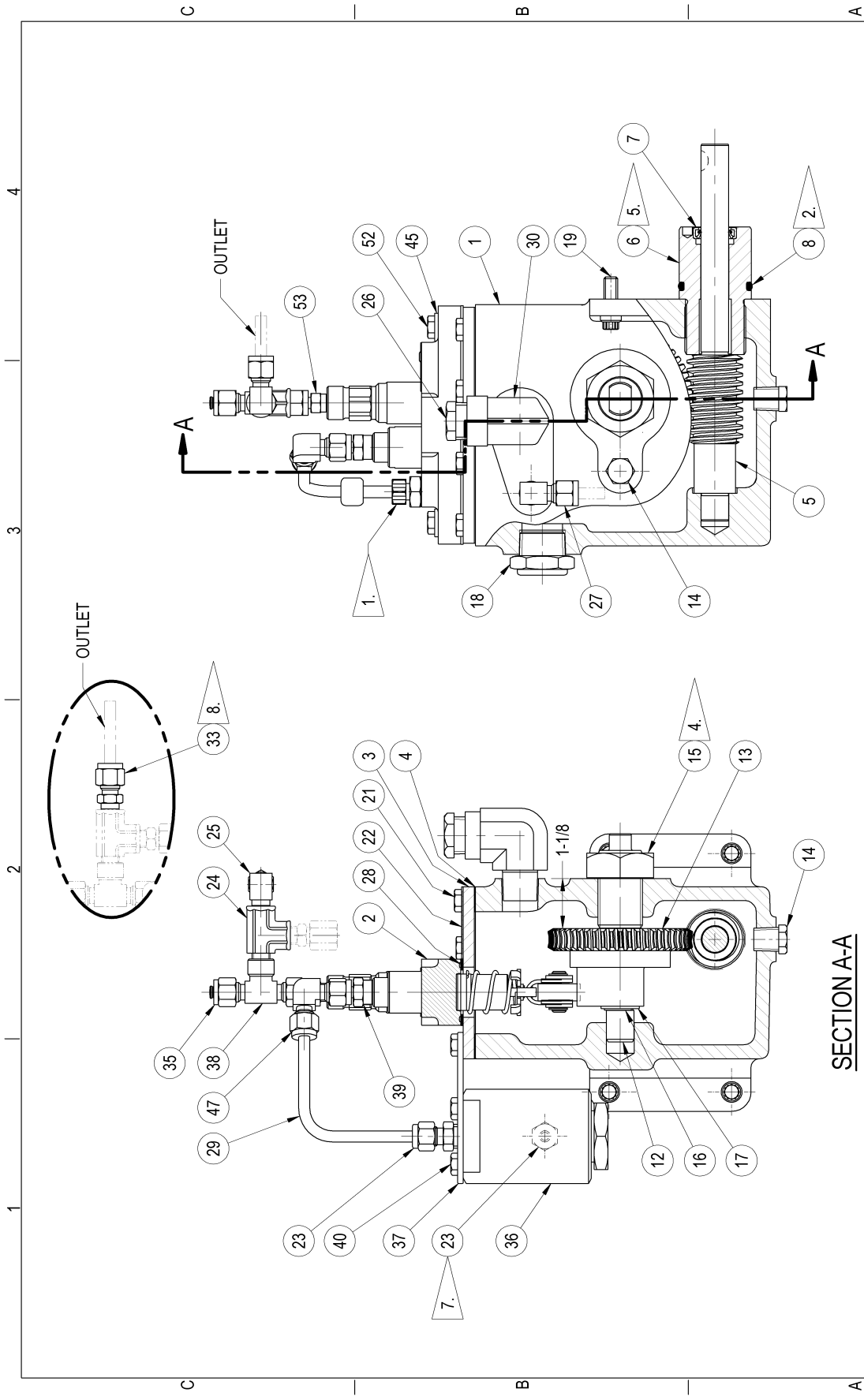
PARTS LIST

77	A-0843	1	STREET ELBOW, STL, 1/2 NPT, 90 DEGREE
86	A-0864	1	MALE BRANCH TEE, STL, 1/2 NPT
87	A-15558	1	STREET TEE, STL, 1/2P
90	A-0828	1	HEX REDUCING NIPPLE, STL, 3/4 NPT(MALE) X 1/2 NPT(MALE)
91	FC0105CE	3	HEX HEAD CAPSCREW, 1/4-28 X 3/4, G9
92	A-0859	1	MALE CONNECTOR, STL, 5/8 TUBE X 1/2 NPT
99	A-18450-A	0	GAUGE, 100PSI, REPLACEMENT SET, BOTTOM MOUNT, 3/8 TUBE
114	A-0934	2	MALE CONN, STL, 3/8T X 1/4P

WHEN A ZERO APPEARS IN THE QUANTITY COLUMN IT  
DOES NOT REPRESENT THE QUANTITY REQUIRED.

\*\*\* ALWAYS PROVIDE SERIAL NUMBER WHEN ORDERING SPARE PARTS. \*\*\*





**SECTION A-A**

**ARIEL CORPORATION**  
 35 BLACKJACK ROAD  
 MOUNT VERNON, OHIO 43050



ASSEMBLY  
 DWG. NO. **A-18919**  
 SHT 1 OF 2

REV	DESCRIPTION	INITIALS	DATE
0	17793	CPM	01/18/12
1	DLI	01/27/12	NONE

THIS DOCUMENT AND CONTENTS THEREIN ARE PROPRIETARY TO ARIEL CORPORATION. ONLY BY WRITTEN CONSENT AND AGREED TERMS BY ARIEL CORPORATION GIVES THE RIGHT TO DISCLOSE OR USE IN PART OR IN WHOLE INFORMATION CONTAINED IN DOCUMENT.

REV	DESCRIPTION	INITIALS	DATE
0	17793	CPM	01/18/12
1	DLI	01/27/12	NONE

1 2 3 4

8/01/12

PARTS LIST

FORCE FEED LUBRICATOR; LUBE PUMP:1/4", QTY=1  
G-SHEETS USED: G-19868, G-19957

PART NO. FF LUBRICATOR ASSY  
REF DRAWING A-18919 2 SHT 2 SHT

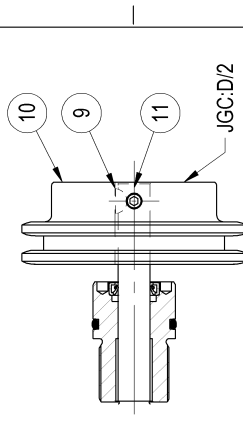
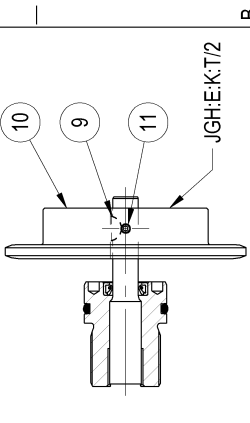
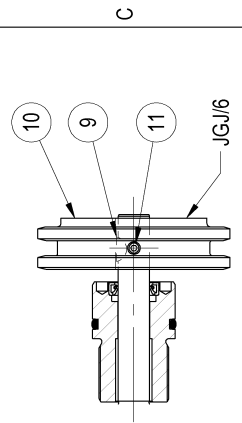
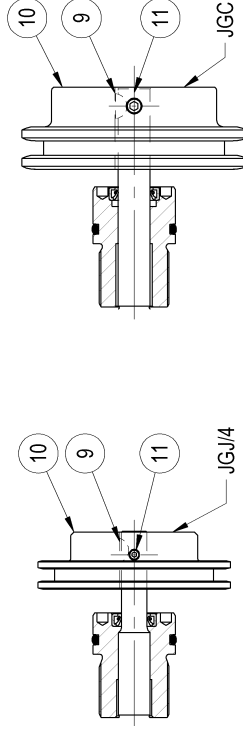
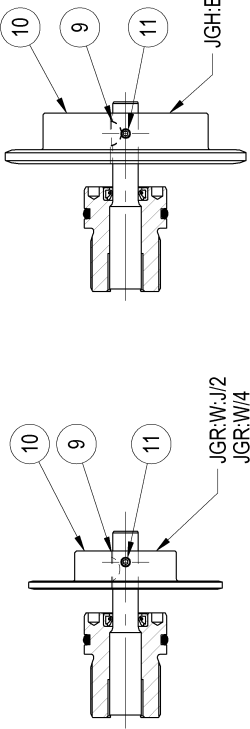
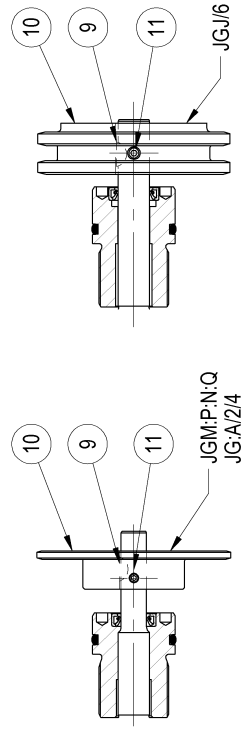
ITEM	PART NUMBER	QTY	DESCRIPTION
1	D-6137	1	FORCE FEED LUBRICATOR, 1 PUMP TANK ASSEMBLY, 1/2 INCH SHAFT
2	A-18526	1	FORCE FEED LUBRICATOR PUMP, 1/4, ARIEL
3	A-2346	0	TOP CVR SINGLE FF LUBE BOX
4	A-2348	0	GSKT,ARL SNGL LUB BOX CVR,1/32
5	A-2360	0	WORM SHAFT,FF LUBR 1/2D E
6	A-5638	0	HSG BRG FF LUBE BOX LH
7	A-3911	0	SHAFT OIL SEAL
8	A-0030	0	O-RING, VT, 1.637 OD X .139, 75/85 DUROMETER
9	FK0360AA	1	WOODRUFF KEY, #204, 1/2 OD X 1/16 WIDE
10	A-0072	1	SPROCKET, 35-1 X 30T, FORCE FEED LUBRICATOR, JG:A/2:4, JGM:P:N:Q:I
11	FS0455CE	1	SET SCREW, CUP POINT, NYLON PATCH, 1/4-28 X 3/4
12	A-2352	0	ADJ SHAFT-SINGLE LUBE BOX
13	B-1176	0	CAM/WORM GEAR,1-PUMP FF LUBR
14	PP0810CB	2	PIPE PLUG,1/4NPT,HEX HD,STL
15	FN0457KA	0	HEX NUT,JAM,STL,1"-14
16	A-2359	0	SNAP RING,STL,RADIAL ASSYO.625
17	A-2358	0	FLAT WASHER,SUPPORT,5/8,HARD
18	A-5641	0	SIGHT GLASS,3/4" NPT
19	FC0120DF	4	12-POINT CAPSCREW, 5/16-18 X 7/8, G8
21	FC0102CE	0	HEX HEAD CAPSCREW, 1/4-20 X 3/4, G5
22	A-16622	1	DATA PLATE, 1 & 2 PUMP FORCE FEED LUBRICATOR
23	A-0827	2	MALE CONNECTOR, STL, 1/4 TUBE X 1/4 NPT

WHEN A ZERO APPEARS IN THE QUANTITY COLUMN IT  
DOES NOT REPRESENT THE QUANTITY REQUIRED.

\*\*\* ALWAYS PROVIDE SERIAL NUMBER WHEN ORDERING SPARE PARTS. \*\*\*

**NOTES:**

1. SCREW IN ADJUSTMENT KNOB TO REDUCE FEED, SCREW ADJUSTMENT KNOB OUT TO INCREASE FEED.
2. OIL O-RING BEFORE INSTALLING.
3. SEE CYLINDER LUBRICATION SHEET FOR CORRECT PUMP SETTING. (DISTRIBUTION BLOCK CYCLE INDICATOR TIMING).
4. TORQUE TO 75 FT-LBS.
5. TORQUE TO 70 FT-LBS.
6. LOOSEN OR TIGHTEN ALL FASTENERS PER RECOMMENDED PROCEDURES AND TORQUE VALUES IN MANUAL.
7. OIL INLET ON BACK SIDE OF FILTER.
8. FOR USE WITH JGHE:K:T/2 ONLY.
9. THIS ASSEMBLY IS FOR ILLUSTRATION PURPOSES ONLY AND MAY NOT NECESSARILY REPRESENT THE EXACT CONFIGURATION PERTAINING TO THE UNIT ORDERED. REFER TO ACCOMPANYING PART LIST FOR ITEMS (AND QUANTITIES OF EACH) REQUIRED FOR THIS PARTICULAR ASSEMBLY.



**ARIEL CORPORATION**  
 35 BLACKJACK ROAD  
 MOUNT VERNON, OHIO 43050

ASSEMBLY DWG. NO.	A-18919	
SCALE	NONE	

REV	REV	REV	REV	REV	REV	REV	REV

DATE	01/18/12
BY	DLI
CHECKED	DLI

DESCRIPTION	
INITIALS	

THIS DOCUMENT AND CONTENTS THEREIN ARE PROPRIETARY TO ARIEL CORPORATION. ONLY BY WRITTEN CONSENT AND AGREED TERMS BY ARIEL CORPORATION GIVES THE RIGHT TO DISCLOSE OR USE IN PART OR IN WHOLE INFORMATION CONTAINED IN DOCUMENT.

8/01/12

PARTS LIST

24	A-15556	1	STREET TEE,STL,1/8P
25	A-0815	1	MALE ELBOW, STL, 1/4 TUBE X 1/8 NPT
26	PP0810GB	1	PIPE PLUG, HEX HEAD, 1/2 NPT, STL
27	A-0800	1	MALE ELBOW, STL, 1/4 TUBE X 1/4 NPT
28	A-18592	0	FF LUBRICATOR PUMP GASKET, 1/16 THICK, ARIEL PUMP
29	PT0200CB	20."	TUBING, SS, 1/4 OD X .035 WALL
30	A-0843	1	STREET ELBOW, STL, 1/2 NPT, 90 DEGREE
35	A-0918	1	PLUG, TUBE FITTING, STL, 1/4 TUBE
36	A-8723	1	FF LUBR FILTER, 150 MIC
37	A-8729	1	BRKT, FF INLET FILTER
38	A-8824	1	FEMALE BRANCH TEE STL1/4TX1/8P
39	A-0809	1	MALE ADAPTOR, STL, 1/4 TUBE X 1/4 NPT
40	FC0102CC	2	HEX HEAD CAPSCREW, 1/4-20 X 1/2, G5
45	FW0500CA	0	WASHER, 1/4 ID, SAE
47	A-0805	1	UNION ELBOW-TUBE, STL, 1/4 TUBE
52	FC0102CH	0	HEX HEAD CAPSCREW, 1/4-20 X 1-1/4, G5
53	A-8828	1	MALE ADAPTR,STL, 1/4T X 1/8P
99	A-18526-A	0	FORCE FEED LUBRICATOR PUMP, REPLACEMENT SET, 1/4, ARIEL
99	A-8723-K	0	FILTER KIT, LUBRICATOR 150 MIC

WHEN A ZERO APPEARS IN THE QUANTITY COLUMN IT  
DOES NOT REPRESENT THE QUANTITY REQUIRED.

\*\*\* ALWAYS PROVIDE SERIAL NUMBER WHEN ORDERING SPARE PARTS. \*\*\*



8/01/12

PARTS LIST

DISTRIBUTION BLOCK, MOUNTING BOLTS AND  
SPACER FOR SINGLE BLOCK. JGM:P

PART NO. G-5095  
REF DRAWING N.A.

ITEM	PART NUMBER	QTY	DESCRIPTION
1	A-5617	2	DIST BLOCK SPACER TRAB
2	FC0102CL	4	HEX HEAD CAPSCREW, 1/4-20 X 2-1/4, G5

WHEN A ZERO APPEARS IN THE QUANTITY COLUMN IT  
DOES NOT REPRESENT THE QUANTITY REQUIRED.

\*\*\* ALWAYS PROVIDE SERIAL NUMBER WHEN ORDERING SPARE PARTS. \*\*\*



8/01/12

PARTS LIST

RUPTURE DISC ASSEMBLY  
7300 PSI

PART NO. G-2706  
REF DRAWING N.A.

ITEM	PART NUMBER	QTY	DESCRIPTION
1	A-3535	1	RUPTURE DISC ASSY,7300 PSI
2	A-3540	0	RUPTURE DISC, 7300 PSIG, BLUE
3	A-2570	1	PLASTIC PLUG/CAP, 5/8 ID HOLE OR 9/16 TUBE, RED

WHEN A ZERO APPEARS IN THE QUANTITY COLUMN IT  
DOES NOT REPRESENT THE QUANTITY REQUIRED.

\*\*\* ALWAYS PROVIDE SERIAL NUMBER WHEN ORDERING SPARE PARTS. \*\*\*





8/01/12

PARTS LIST

FORCE FEED LUBRICATION TUBING FOR JGM/2, PART NO. G-1080  
JGA/2, JG/2, JGP/2 WITH DOUBLE ACTING REF DRAWING N.A.  
CYLINDER AND TANDEM

ITEM	PART NUMBER	QTY	DESCRIPTION
1	PT0200CB	100."	TUBING, SS, 1/4 OD X .035 WALL
2	A-0886	1	BULKHEAD UNION, STL, 1/4 TUBE
3	A-0401	1	BRACKET, BULKHEAD UNION
4	FC0102CC	1	HEX HEAD CAPSCREW, 1/4-20 X 1/2, G5

WHEN A ZERO APPEARS IN THE QUANTITY COLUMN IT  
DOES NOT REPRESENT THE QUANTITY REQUIRED.

\*\*\* ALWAYS PROVIDE SERIAL NUMBER WHEN ORDERING SPARE PARTS. \*\*\*



8/01/12

PARTS LIST

FORCE FEED LUBRICATION TUBING  
JGM/2, JGP/2, JGA/2, JG/2  
WITH TWO DOUBLE ACTING CYLINDERS

PART NO. G-1079  
REF DRAWING N.A.

ITEM	PART NUMBER	QTY	DESCRIPTION
1	PT0200CB	250."	TUBING, SS, 1/4 OD X .035 WALL
2	A-0886	2	BULKHEAD UNION, STL, 1/4 TUBE
3	A-0401	2	BRACKET, BULKHEAD UNION
4	FC0102CC	2	HEX HEAD CAPSCREW, 1/4-20 X 1/2, G5

WHEN A ZERO APPEARS IN THE QUANTITY COLUMN IT  
DOES NOT REPRESENT THE QUANTITY REQUIRED.

\*\*\* ALWAYS PROVIDE SERIAL NUMBER WHEN ORDERING SPARE PARTS. \*\*\*



8/01/12

PARTS LIST

FORCE FEED LUBRICATION TUBING                      PART NO. G-2935  
BOTTOM LUBE - EACH CYLINDER                      REF DRAWING N.A.  
JG:A:M:P:N:Q:R:W:J:H:E:K:T

ITEM	PART NUMBER	QTY	DESCRIPTION
1	PT0200CB	90."	TUBING, SS, 1/4 OD X .035 WALL
2	A-0886	1	BULKHEAD UNION, STL, 1/4 TUBE
3	A-0401	1	BRACKET, BULKHEAD UNION
4	FC0102CC	1	HEX HEAD CAPSCREW, 1/4-20 X 1/2, G5
5	A-0831	1	TUBING CLAMP, 1/4 TUBE
6	FM0400BC	1	MACHINE SCREW, SLOTTED, #10-24 X 1/2
7	FW0500AA	1	FLAT WASHER, #8 SAE

WHEN A ZERO APPEARS IN THE QUANTITY COLUMN IT  
DOES NOT REPRESENT THE QUANTITY REQUIRED.

\*\*\* ALWAYS PROVIDE SERIAL NUMBER WHEN ORDERING SPARE PARTS. \*\*\*



8/01/12

PARTS LIST

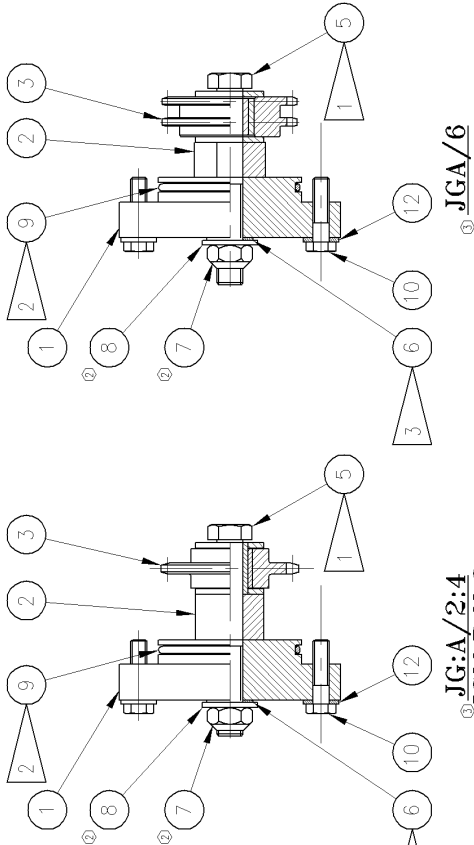
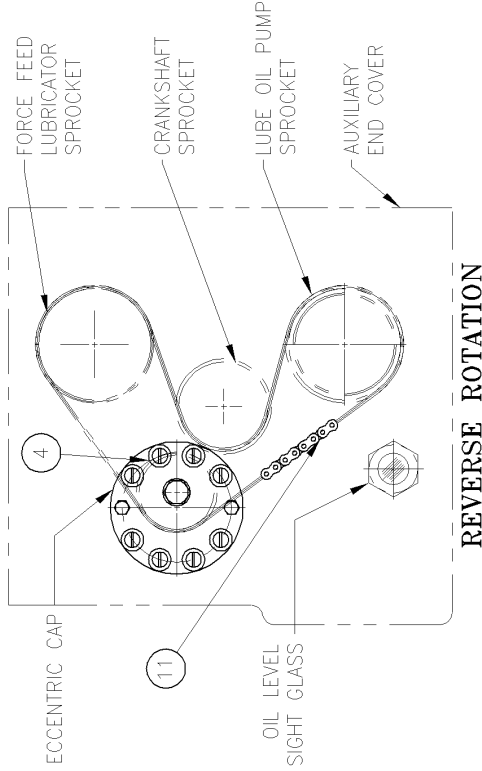
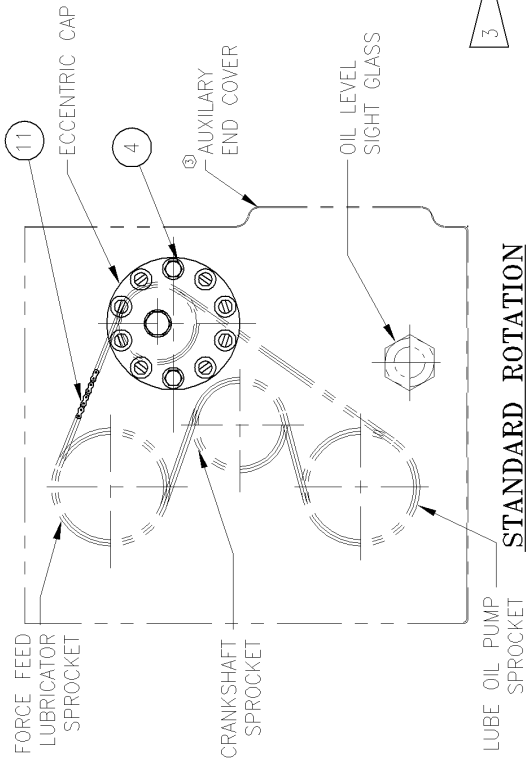
FORCE FEED LUBRICATION TUBING FOR UNITS      PART NO. G-9055  
WITH CYLINDERS OVER 3700 MAWP.              REF DRAWING N.A.  
JGM THROUGH JGR/2

ITEM	PART NUMBER	QTY	DESCRIPTION
1	PT0201CD	255."	TUBING, 316 SS, 1/4 OD X .065 WALL

WHEN A ZERO APPEARS IN THE QUANTITY COLUMN IT  
DOES NOT REPRESENT THE QUANTITY REQUIRED.

\*\*\* ALWAYS PROVIDE SERIAL NUMBER WHEN ORDERING SPARE PARTS. \*\*\*





- NOTES:
- ① USE NEW CAPSCREW AND NUT (ITEM#5&7) WHEN REPLACING IDLER SPROCKET (ITEM#3).
  - ② OIL O-RING (ITEM#9) BEFORE INSTALLING.
  - ③ OIL FACES BEFORE INSTALLING TO PREVENT ABRASION OF STATO-SEAL (ITEM #6).
  - ④ FOR CHAIN TIGHTENING REFER TO ER-74.
  - ⑤ LOOSEN OR TIGHTEN ALL FASTENERS PER RECOMMENDED PROCEDURES AND TORQUE VALUES IN MANUAL.

REV	DESCRIPTION	INIT/DATE
4	④ REVISED CHAIN TIGHTENING NOTE.	RWP 8/26/04
3	④ "C2" CORRECTED SPELLING OF AUXILIARY NOTE #4 (2) CAP SCREWS WAS (4), (8) PLUGS WAS (16), ④ "C4" ADDED JGA/6 VIEW, ④ "B3" ADDED TITLE JGA/2: & JGMP:R&A, ④ "B4" ADDED TITLE JGA/6.	JS 0/17/01

3	8412	4	11872	1	8281
2	8434	0	7220	0	7220
DRAWN: MA 6/25/98		APPROVER: NONE		SCALE: NONE	
CHECKED: ECN		REV		3	

**ARIEL CORPORATION**  
 35 BLACKJACK ROAD  
 MOUNT VERNON, OHIO 43050

ASSEMBLY DWG. NO. **A-7765**

8/01/12

PARTS LIST

CHAIN DRIVE, STANDARD OR REVERSE ROTATION  
JGM, JGP, JGN, JGQ

PART NO. G-0176  
REF DRAWING A-7765

ITEM	PART NUMBER	QTY	DESCRIPTION
1	B-0030	1	ECCENTRIC VERNIER CAP
2	A-0071	1	IDLER SPACER, JG:A/2:4 AND JGI
3	A-0085	1	SPKT, 35-1 X 20T
4	A-0109	8	MACHINE SCREW PLUG, PLASTIC, 7/16-14
5	FC0107GS	1	HEX HEAD CAPSCREW, 1/2-20 X 4, G5
6	FW0550GA	1	STAT-O-SEAL, 1/2 DIA., BLACK
7	FN0468GA	1	HEX NUT, STOVER TYPE C, 1/2-20
8	FW0500GA	1	FLAT WASHER, 1/2 SAE
9	A-0010	1	O-RING, VT, 2.637 O.D. X .139
10	FC0100DH	2	HEX HEAD CAPSCREW, 5/16-18 X 1-1/4, G9
11	A-0203	1	CHAIN, 35-1 X 94
12	FW0501CA	2	WASHER, 5/16 ID, PLAIN

WHEN A ZERO APPEARS IN THE QUANTITY COLUMN IT  
DOES NOT REPRESENT THE QUANTITY REQUIRED.

\*\*\* ALWAYS PROVIDE SERIAL NUMBER WHEN ORDERING SPARE PARTS. \*\*\*



8/01/12

PARTS LIST

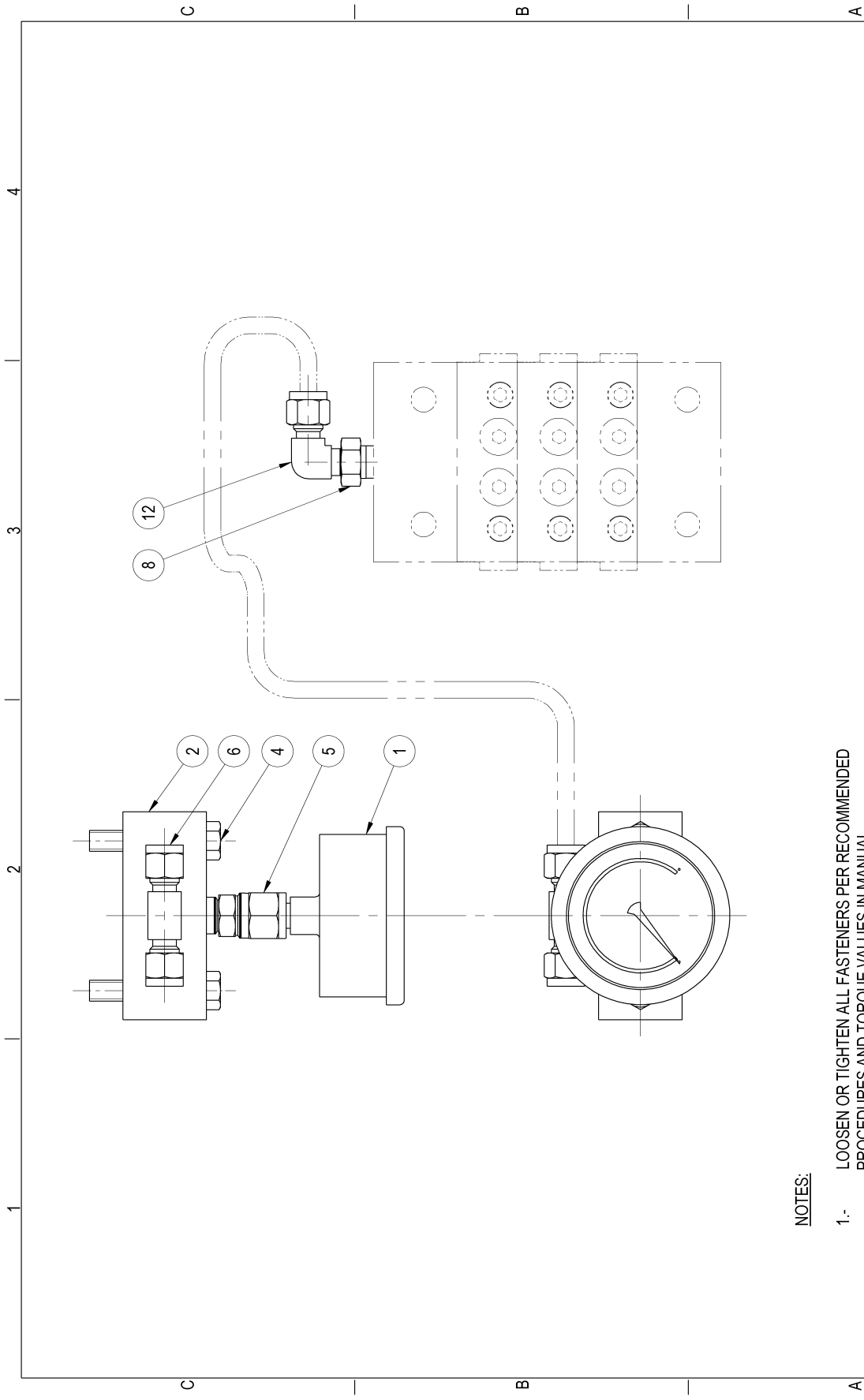
TOP COVER AND BREATHER  
JGM, JGP, JGN, JGQ FOR STANDARD AND  
REVERSE ROTATION.

PART NO. G-0173  
REF DRAWING A-7931

ITEM	PART NUMBER	QTY	DESCRIPTION
1	B-0103	1	COVER, TOP, JGM:P
2	B-0104	1	GSKT,RET, TOP CVR,M:P, 1/32
3	A-2958	2	TOP / SIDE COVER HANDLE, AL, 2 HOLE
4	FC0134CD	4	BUTTON HEAD CAPSCREW, 1/4-20 X 5/8, 316SS
5	B-4798	1	BREATHER, 1" NPT, FRAME
6	A-10186	16	SEMS BOLT, 5/16-18 X 1-1/4, G5
7	A-0463	1	CAUTION PLATE, CYLINDER VENTING
8	A-0138	1	NAME PLATE, ARIEL LOGO
9	FC0134BC	4	BUTTON HEAD CAPSCREW, #10-24 X 1/2, 316SS
10	A-0713	1	INFORMATION PLATE, LUBE OIL FILTER, SPIN-ON
11	A-14766	1	DATA PLATE, FRAME SPECIFICATION
12	FR0571CC	15	DRIVE SCREW, TYPE U, SS, #6 X 1/4
13	A-0719	1	INFORMATION PLATE, ROTATION ARROW
14	A-0464	1	CAUTION PLATE, COMPRESSOR VALVE
15	A-7655	1	PIPE PLUG,1"NPT,SLOTTED HEAD
16	A-0009	1	O-RING, VT, 1.387 OD X .139, 75/85 DUROMETER
20	FC0134BB	2	BUTTON HEAD CAPSCREW, #10-24 X 3/8, 316SS

WHEN A ZERO APPEARS IN THE QUANTITY COLUMN IT  
DOES NOT REPRESENT THE QUANTITY REQUIRED.

\*\*\* ALWAYS PROVIDE SERIAL NUMBER WHEN ORDERING SPARE PARTS. \*\*\*



**NOTES:**

- 1.- LOOSEN OR TIGHTEN ALL FASTENERS PER RECOMMENDED PROCEDURES AND TORQUE VALUES IN MANUAL.

**ARIEL CORPORATION**  
 35 BLACKJACK ROAD  
 MOUNT VERNON, OHIO 43050



ASSEMBLY  
 DWG. NO. **A-18429**  
 SHT 1 OF 1

SCALE NONE

DRAWN CPM 08/29/11  
 CHECKED DLI 09/01/11

0 17756  
 REV EON REV EON

THIS DOCUMENT AND CONTENTS THEREIN ARE PROPRIETARY TO ARIEL CORPORATION. ONLY BY WRITTEN CONSENT AND AGREED TERMS BY ARIEL CORPORATION GIVES THE RIGHT TO DISCLOSE OR USE IN PART OR IN WHOLE INFORMATION CONTAINED IN DOCUMENT.

REV	DESCRIPTION	INITIALS	DATE

8/01/12

PARTS LIST

FORCE FEED PRESSURE GAUGE  
7500 PSI, GAUGE WITH 3/8 TUBE ADAPTER,  
MOUNTS TO GAUGE BRACKET FOR JGM:N:P:Q

PART NO. G-19557  
REF DRAWING A-18429

ITEM	PART NUMBER	QTY	DESCRIPTION
1	A-17258	1	PRESSURE GAUGE, 7500 PSI, BACK MOUNT, 3/8 TUBE, SS
2	A-9019	1	BRACKET, FORCE FEED GAUGE MOUNTING
4	FC0102DJ	2	HEX HEAD CAPSCREW, 5/16-18 X 1-3/4, G5
5	A-0934	1	MALE CONN,STL, 3/8T X 1/4P
6	A-2288	1	MALE BRANCH T, 1/4T X 1/8P
8	A-0811	1	HEX REDUCING BUSHING, 1/4 NPT (MALE) X 1/8 NPT (FEMALE), STL
12	A-0815	1	MALE ELBOW, STL, 1/4 TUBE X 1/8 NPT
99	A-17258-A	0	GAUGE, 7500PSI, REPLACEMENT SET, BACK MOUNT, 3/8 TUBE

WHEN A ZERO APPEARS IN THE QUANTITY COLUMN IT  
DOES NOT REPRESENT THE QUANTITY REQUIRED.

\*\*\* ALWAYS PROVIDE SERIAL NUMBER WHEN ORDERING SPARE PARTS. \*\*\*



8/01/12

PARTS LIST

FORCE FEED LUBRICATOR PRO-FLO-JR TIMER      PART NO. G-14217  
WITH PROXIMITY SWITCH.                              REF DRAWING N.A.

ITEM	PART NUMBER	QTY	DESCRIPTION
1	A-13894	1	FF.S/D,PRO-FLO-JR,TRAB

WHEN A ZERO APPEARS IN THE QUANTITY COLUMN IT  
DOES NOT REPRESENT THE QUANTITY REQUIRED.

\*\*\* ALWAYS PROVIDE SERIAL NUMBER WHEN ORDERING SPARE PARTS. \*\*\*





8/01/12

PARTS LIST

SPECIAL TOOLS  
JG:A/2:4, JGP:Q/1:2, JGM:N/1:2, JGS, JGI

PART NO. G-16340  
REF DRAWING N.A.

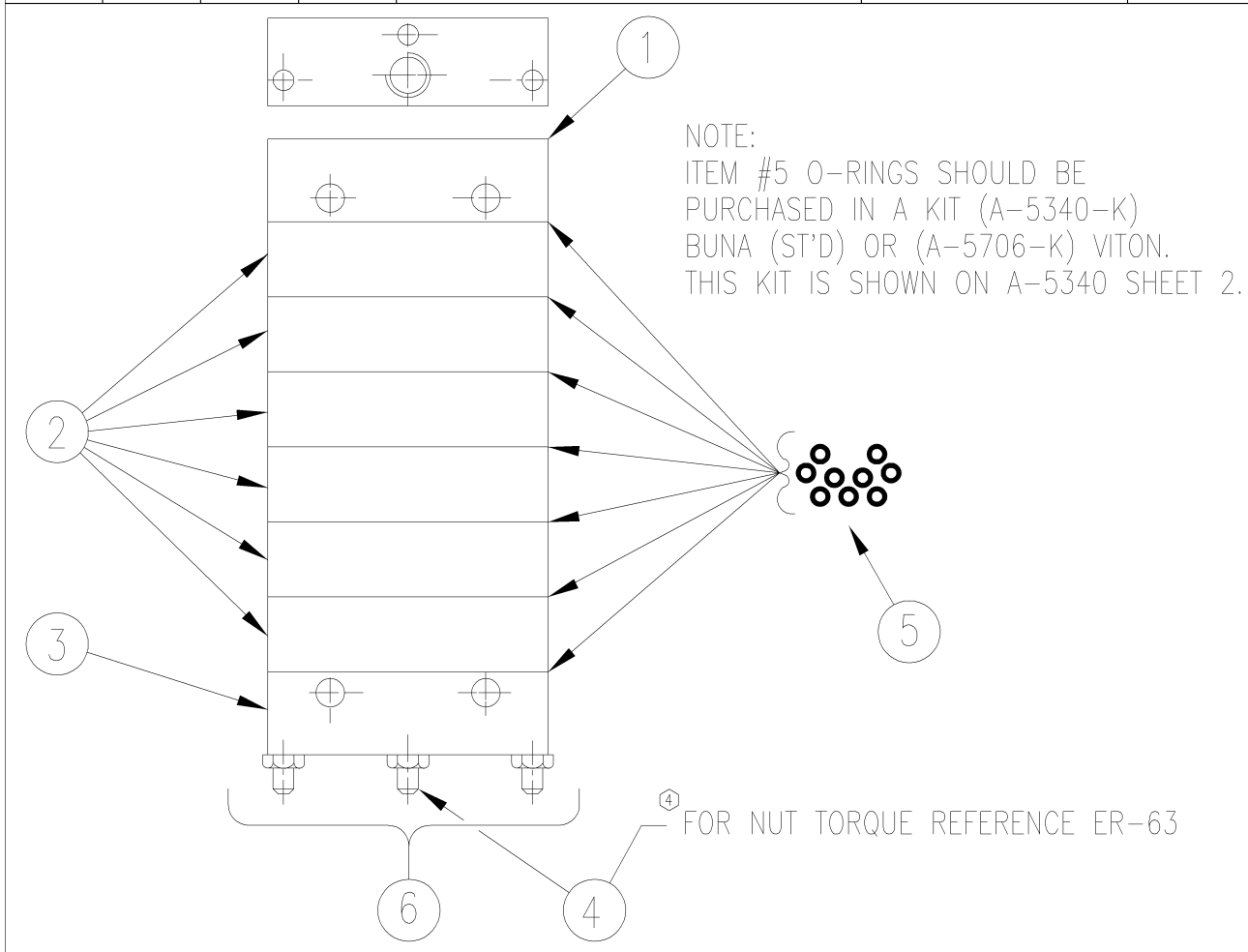
ITEM	PART NUMBER	QTY	DESCRIPTION
1	A-0076	1	PEG WRENCH, 3/4"
2	A-0135	1	VALVE PULLER, 5/16 X 1/2 UNF
3	A-0279	1	PISTON NUT SPANNER, JG:M:P
4	A-0409	1	VALVE PULLER, 1/4-28 X 3/8-24
5	A-0798	1	TOOL BOX
6	B-0016	1	CROSSHEAD NUT WRENCH, 2 INCH
7	TA0100CA	10	ALLEN WRENCH, 3/32 SHORT ARM
8	TA0100EA	10	ALLEN WRENCH, 1/8 SHORT ARM
9	TA0100FA	1	ALLEN WRENCH, 9/64 SHORT ARM
10	TA0100GA	5	ALLEN WRENCH, 5/32 SHORT ARM
11	TA0100HA	5	ALLEN WRENCH, 3/16 SHORT ARM
12	TA0100JA	3	ALLEN WRENCH, 1/4 SHORT ARM
13	TA0100KA	3	ALLEN WRENCH, 5/16 SHORT ARM
14	TA0100LB	2	ALLEN WRENCH, 3/8 LONG ARM
15	ER-63	1	TORQUE CHART, ALL UNITS
16	A-8158	0	BRG HSG SPANNER WRENCH
17	A-14781	1	PISTON ROD ENTERING SLEEVE, 2PC, JG:A:M:P:N:Q
18	A-15236	1	THREAD GAUGE


WHEN A ZERO APPEARS IN THE QUANTITY COLUMN IT  
DOES NOT REPRESENT THE QUANTITY REQUIRED.

\*\*\* ALWAYS PROVIDE SERIAL NUMBER WHEN ORDERING SPARE PARTS. \*\*\*

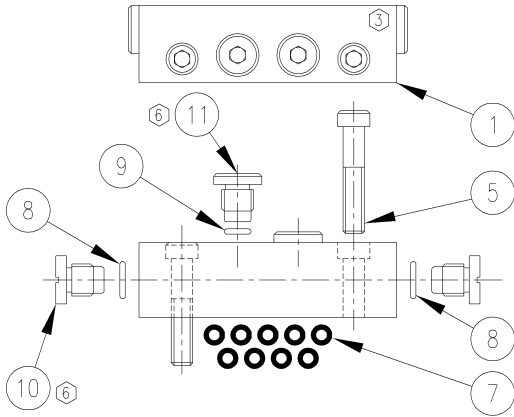


NUMBER OF BASE PLATES SECTIONS				DESCRIPTION	ARIEL PART No.	ITEM
3	4	5	6			
1	1	1	1	INLET SECTION	A-5537	1
3	4	5	6	INTERMEDIATE SECTION	A-5531	2
1	1	1	1	END SECTION	A-5538	3
3				TIE ROD W/NUT	A-5539	4
	3			TIE ROD W/NUT	A-5540	
		3		TIE ROD W/NUT	A-5541	
			3	TIE ROD W/NUT	A-5542	
36	45	54	63	O-RING, BUNA STANDARD	A-5570	5
36	45	54	63	O-RING, VITON	A-5703	
A-5533	A-5534	A-5535	A-5536	COMPLETE BASE PLATE ASSEMBLY		6

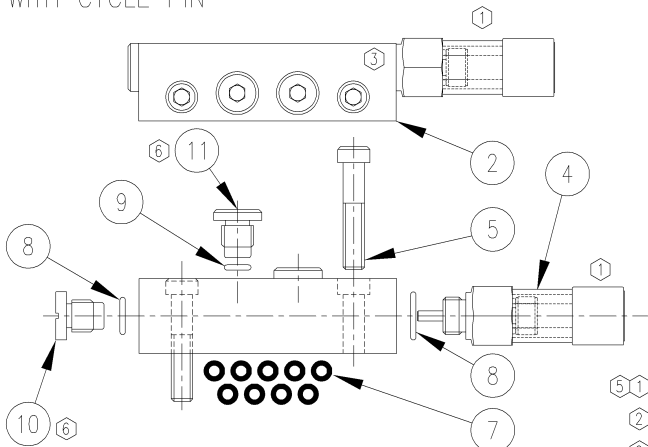


		5	14799	3	10737	 <b>ARIEL CORPORATION</b> 35 BLACKJACK ROAD MOUNT VERNON, OHIO 43050	TITLE: DISTRIBUTION BLOCK VALVE ⑤ DRAWING No. <b>A-5340</b> SHT 1 OF 2
		6	17759	4	12506		
⑥	ON SHEET 2: ADDED ITEM BALLOONS 10 & 11 TO WITHOUT CYCLE PIN & WITH CYCLE PIN VIEWS. ADDED NOTE QTY. (1) ITEM 10 REQUIRED WHEN ITEM 4 IS INSTALLED. ADDED ITEMS 10 & 11 TO TABLE.			DPD	1	8175	
REV	DESCRIPTION	INT/DATE	REV	ECN			

WITHOUT CYCLE PIN

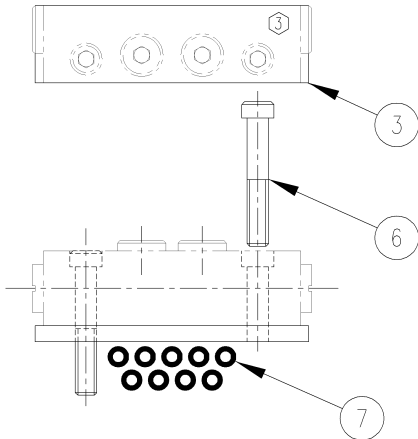


WITH CYCLE PIN



QTY. (1) ITEM #10 REQUIRED WHEN ITEM #4 IS INSTALLED

CROSSPORT



ITEM	ARIEL PART	QUAN	DESCRIPTION
1	A-5543	1	DIVIDER VALVE, 6T
	A-5545	1	DIVIDER VALVE, 6S
	A-5547	1	DIVIDER VALVE, 9T
	A-5549	1	DIVIDER VALVE, 9S
	A-5551	1	DIVIDER VALVE, 12T
	A-5553	1	DIVIDER VALVE, 12S
	A-5555	1	DIVIDER VALVE, 18T
	A-5557	1	DIVIDER VALVE, 18S
	A-5559	1	DIVIDER VALVE, 24T
	A-5561	1	DIVIDER VALVE, 24S
	A-5563	1	DIVIDER VALVE, 30T
	A-5565	1	DIVIDER VALVE, 30S
	2	A-5544	1
A-5546		1	DIVIDER VALVE, 6S W/CIP
A-5548		1	DIVIDER VALVE, 9T W/CIP
A-5550		1	DIVIDER VALVE, 9S W/CIP
A-5552		1	DIVIDER VALVE, 12T W/CIP
A-5554		1	DIVIDER VALVE, 12S W/CIP
A-5556		1	DIVIDER VALVE, 18T W/CIP
A-5558		1	DIVIDER VALVE, 18S W/CIP
A-5560		1	DIVIDER VALVE, 24T W/CIP
A-5562		1	DIVIDER VALVE, 24S W/CIP
3	A-5564	1	DIVIDER VALVE, 30T W/CIP
	A-5566	1	DIVIDER VALVE, 30S W/CIP
	A-5567	1	CROSSPORT BAR, RIGHT
3	A-5568	1	CROSSPORT BAR, LEFT
	A-5569	1	CROSSPORT BAR, BOTH
4	A-14282	1	CYCLE INDICATOR
5	FC0115CH	2	SOC. CAP. 1/4-28 X 1-1/4
6	FC0115CI	2	SOC. CAP. 1/4-28 X 1-1/2

NOTE:

O-RINGS SHOULD BE PURCHASED IN A KIT (A-5340-K) BUNA (ST'D) OR (A-5706-K) VITON. THE KITS CONTAIN THE FOLLOWING O-RINGS:

7	A-5570	20	O-RING, INTERFACE, BUNA
	A-5703	20	O-RING, INTERFACE, VITON
8	A-5696	4	O-RING, ENCLOSURE, BUNA
	A-5704	4	O-RING, ENCLOSURE, VITON
9	A-5695	4	O-RING, OUTLET, BUNA
	A-5705	4	O-RING, OUTLET, VITON
10	A-14300	2	SERIES "A" PISTON PLUG
	A-16800	2	SERIES "B" PISTON PLUG
11	A-18405	2	INDICATOR PORT PLUG

6	17759	4	12506
5	14799	3	10737

6	SEE SHEET 1 FOR REVISIONS.	DPD 7/11/12	2	8200
	5	SEE SHEET #1 FOR REVISIONS.	DLI 02/07/08	1
REV		DESCRIPTION	INT/DATE	REV



ARIEL CORPORATION  
35 BLACKJACK ROAD  
MOUNT VERNON, OHIO 43050

TITLE: DISTRIBUTION BLOCK VALVE	DRAWING No. A-5340 SHT 2 OF 2
---------------------------------	-------------------------------

# **1<sup>ST</sup> STAGE CYLINDER**

**THIS PAGE LEFT INTENTIONALLY BLANK**

8/01/12

ARIEL CORPORATION  
SALES ORDER COVER SHEET

C/N: 001

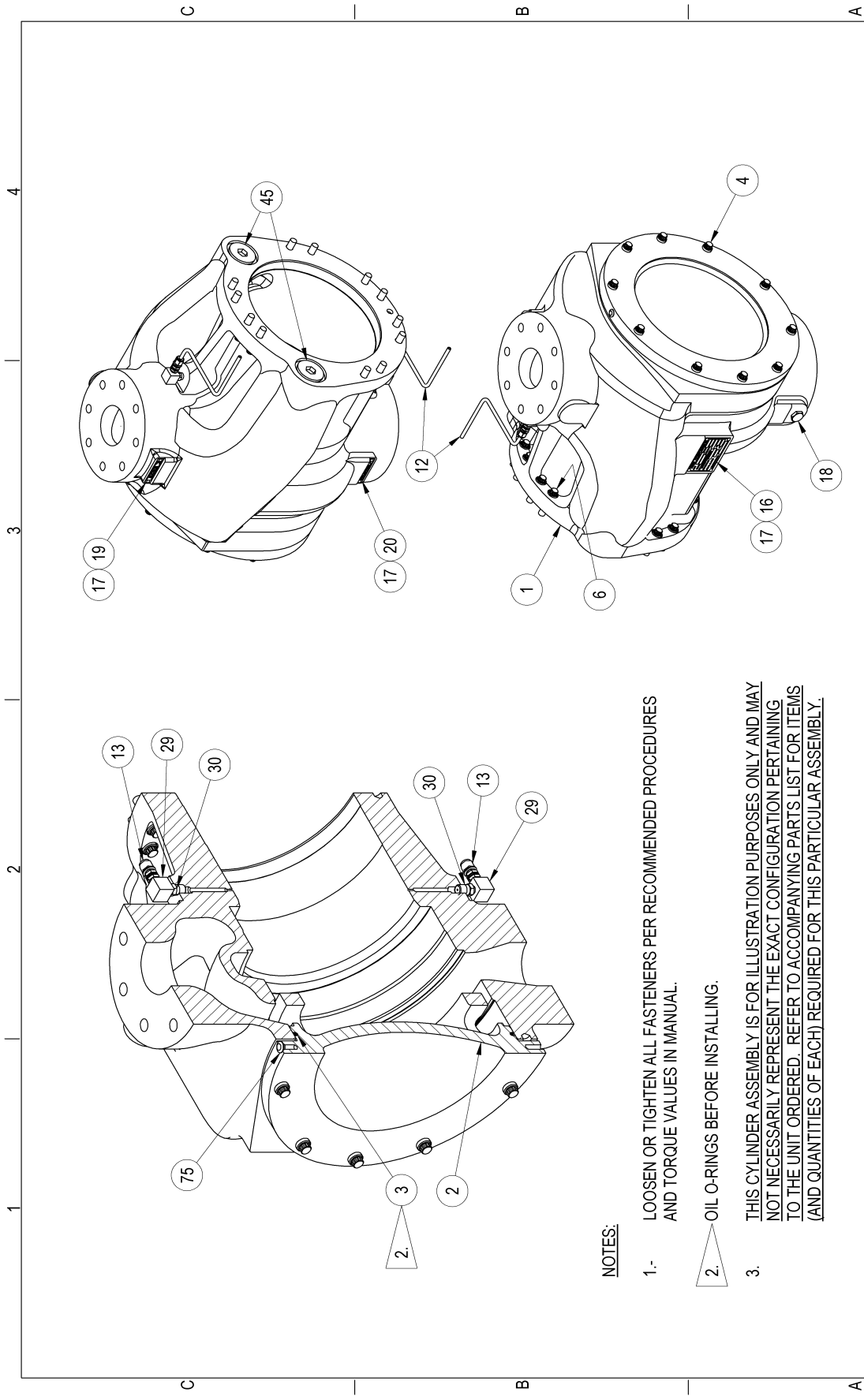
RHCOVP02

SERIAL #: C-136422

PART: 10-3/4P HE      DESCRIPTION: 10-3/4" JGP HE CYLINDER CLASS

PART NUMBER	QTY	DESCRIPTION	DRAWING NO.
G-20734	1	CYLINDER ASSEMBLY, 10-3/4P-HE, STD, 225	A-17826
G-19423	1	CONCENTRIC VALVE ASSEMBLY, 10-3/4P-HE, MID CLEARANCE POSITION	A-17840
G-18526	1	PISTON ASSEMBLY, 10-3/4P-HE, STD	A-17849
B-5840-GG	1	CONCENTRIC VALVE, 147CT/256CFS	A-17491
G-18897	1	VALVE PULLER, 10-3/4P-HE	A-17801





**NOTES:**

- 1.- LOOSEN OR TIGHTEN ALL FASTENERS PER RECOMMENDED PROCEDURES AND TORQUE VALUES IN MANUAL.
2. OIL O-RINGS BEFORE INSTALLING.
3. THIS CYLINDER ASSEMBLY IS FOR ILLUSTRATION PURPOSES ONLY AND MAY NOT NECESSARILY REPRESENT THE EXACT CONFIGURATION PERTAINING TO THE UNIT ORDERED. REFER TO ACCOMPANYING PARTS LIST FOR ITEMS (AND QUANTITIES OF EACH) REQUIRED FOR THIS PARTICULAR ASSEMBLY.

**ARIEL CORPORATION**  
 35 BLACKJACK ROAD  
 MOUNT VERNON, OHIO 43050



ASSEMBLY  
 DWG. NO. **A-17826**  
 SHT 1 OF 1

REV	DESCRIPTION	INITIALS	DATE
0	17066	CPM	01/21/11
REV	EON	DLI	01/31/11
REV	EON	SCALE	NONE

THIS DOCUMENT AND CONTENTS THEREIN ARE PROPRIETARY TO ARIEL CORPORATION. ONLY BY WRITTEN CONSENT AND AGREED TERMS BY ARIEL CORPORATION GIVES THE RIGHT TO DISCLOSE OR USE IN PART OR IN WHOLE INFORMATION CONTAINED IN DOCUMENT.

REV	DESCRIPTION	INITIALS	DATE
0	17066	CPM	01/21/11
REV	EON	DLI	01/31/11
REV	EON	SCALE	NONE

8/01/12

PARTS LIST

10-3/4P-HE TANDEM CYLINDER BODY AND  
HEAD END HEAD.  
RDP 205#, MAWP 225#

PART NO. G-20734  
REF DRAWING A-17826

ITEM	PART NUMBER	QTY	DESCRIPTION
1	D-5893	0	CYLINDER, 10-3/4P-HE, 225 MAWP
2	C-5970	0	HEAD END HEAD, 10-3/4P-HE, 225 MAWP CYLINDER
3	A-0469	1	O-RING, VT, 13.395 OD X .210, 75/85 DUROMETER
4	FC0120GM	10	12-POINT CAPSCREW, 1/2-13 X 2-1/2, G8
6	FC0120GK	12	12-POINT CAPSCREW, 1/2-13 X 2, G8
12	PT0200CB	36."	TUBING, SS, 1/4 OD X .035 WALL
13	A-18496	2	CHECK VALVE, DOUBLE BALL, SS, 1/4 TUBE INLET X 1/8 NPT OUTLET,
16	A-0465	1	DATA PLATE, CYLINDER SPECIFICATION, 3-1/2 X 2-1/4
17	FR0571CC	8	DRIVE SCREW, TYPE U, SS, #6 X 1/4
18	PP0810GB	1	PIPE PLUG, HEX HEAD, 1/2 NPT, STL
19	A-0640-A	1	INFORMATION PLATE, SUCTION
20	A-0640-B	1	INFORMATION PLATE, DISCHARGE
29	A-17774	2	OIL TRAP, BODY, SS, 1/8 NPT
30	A-17776	2	OIL TRAP, STEM, SS, 1/4 NPT
45	PP0861LB	2	SAE PLUG, SOCKET HEAD, #24, 1-7/8-12
75	A-0467	2	PUSH-IN PLUG, PLASTIC, 3/8 THREAD, YELLOW
100	HD-5893	1	CYLINDER HYDROTEST SET, 10-3/4P-HE, 225 MAWP

WHEN A ZERO APPEARS IN THE QUANTITY COLUMN IT  
DOES NOT REPRESENT THE QUANTITY REQUIRED.

\*\*\* ALWAYS PROVIDE SERIAL NUMBER WHEN ORDERING SPARE PARTS. \*\*\*



8/01/12

PARTS LIST

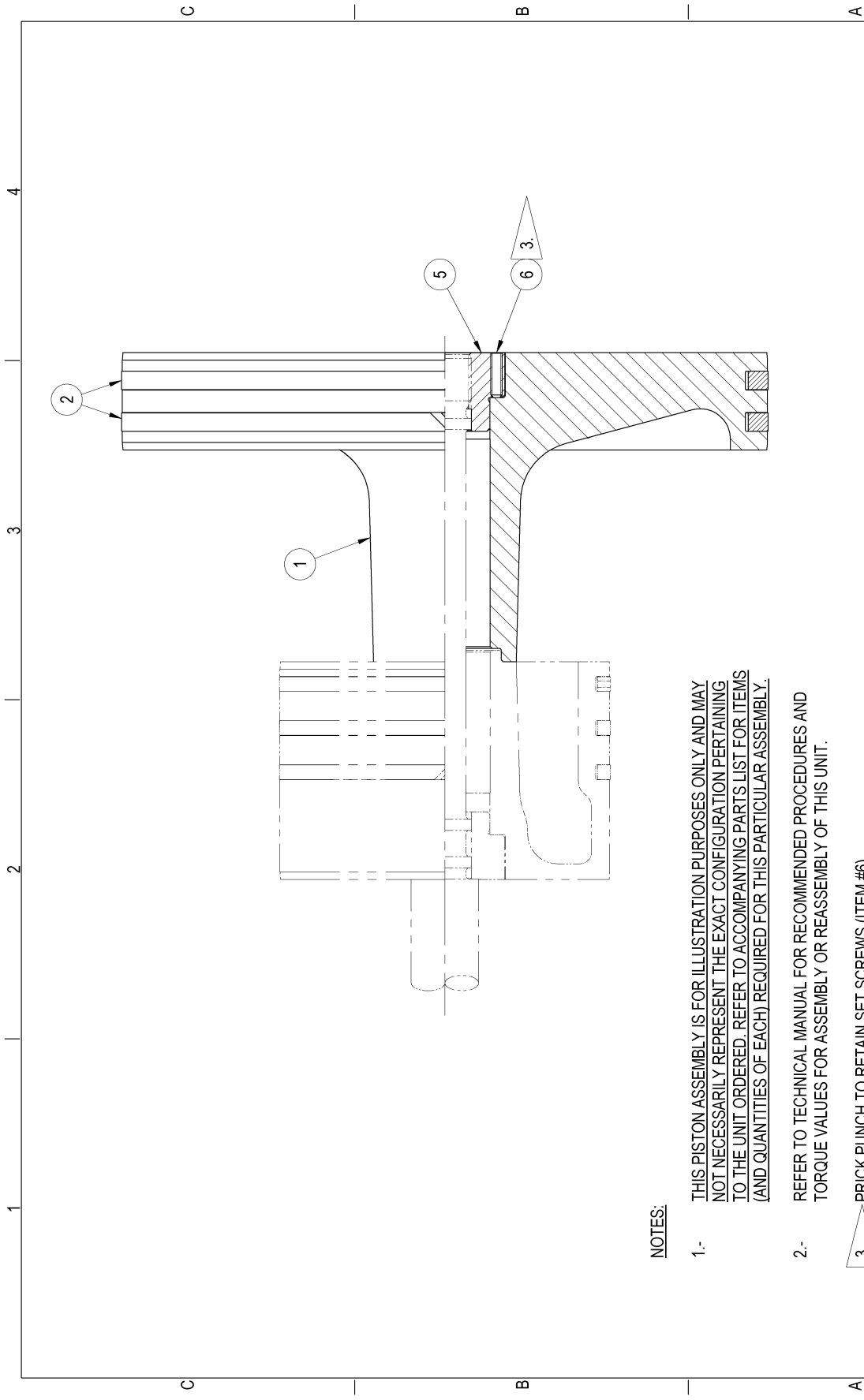
CONCENTRIC VALVE, RETAINER, SPACERS  
10-3/4P-HE CLASS, STEEPLE CYLINDER  
MID CLEARANCE POSITION: ONE SPACER  
INSTALLED UNDER VALVE.

PART NO. G-19423  
REF DRAWING A-17840


ITEM	PART NUMBER	QTY	DESCRIPTION
1	CONCENTRIC VLV	0	FOR PART NO. SEE COVER SHEET
3	B-5717	1	VALVE RETAINER, 10-3/4P-HE
9	A-17455	2	HIGH CLEARANCE VALVE SPACER, 10-3/4P-HE
17	A-0653	1	O-RING, VT, 12.395 OD X .210, 75/85 DUROMETER
18	A-10434	1	O-RING, VT, 6.512 OD X .139, 75/85 DUROMETER
19	A-15072	1	O-RING, VT, 11.895 OD X .210, 75/85 DUROMETER

WHEN A ZERO APPEARS IN THE QUANTITY COLUMN IT  
DOES NOT REPRESENT THE QUANTITY REQUIRED.

\*\*\* ALWAYS PROVIDE SERIAL NUMBER WHEN ORDERING SPARE PARTS. \*\*\*



**NOTES:**

- 1.- THIS PISTON ASSEMBLY IS FOR ILLUSTRATION PURPOSES ONLY AND MAY NOT NECESSARILY REPRESENT THE EXACT CONFIGURATION PERTAINING TO THE UNIT ORDERED. REFER TO ACCOMPANYING PARTS LIST FOR ITEMS (AND QUANTITIES OF EACH) REQUIRED FOR THIS PARTICULAR ASSEMBLY.
- 2.- REFER TO TECHNICAL MANUAL FOR RECOMMENDED PROCEDURES AND TORQUE VALUES FOR ASSEMBLY OR REASSEMBLY OF THIS UNIT.
- 3.  PRICK PUNCH TO RETAIN SET SCREWS (ITEM #6).

**ARIEL CORPORATION**  
 35 BLACKJACK ROAD  
 MOUNT VERNON, OHIO 43050



ASSEMBLY  
 DWG. NO. **A-17849**  
 SHT. 1 OF 1

REV	DESCRIPTION	INITIALS	DATE
0	17066	CPM	01/26/11
0	17066	EDN	01/28/11
0	17066	EDN	01/28/11
0	17066	EDN	01/28/11

THIS DOCUMENT AND CONTENTS THEREIN ARE PROPRIETARY TO ARIEL CORPORATION. ONLY BY WRITTEN CONSENT AND AGREED TERMS BY ARIEL CORPORATION GIVES THE RIGHT TO DISCLOSE OR USE IN PART OR IN WHOLE INFORMATION CONTAINED IN DOCUMENT.

REV	DESCRIPTION	INITIALS	DATE
0	17066	CPM	01/26/11
0	17066	EDN	01/28/11
0	17066	EDN	01/28/11
0	17066	EDN	01/28/11

8/01/12

PARTS LIST

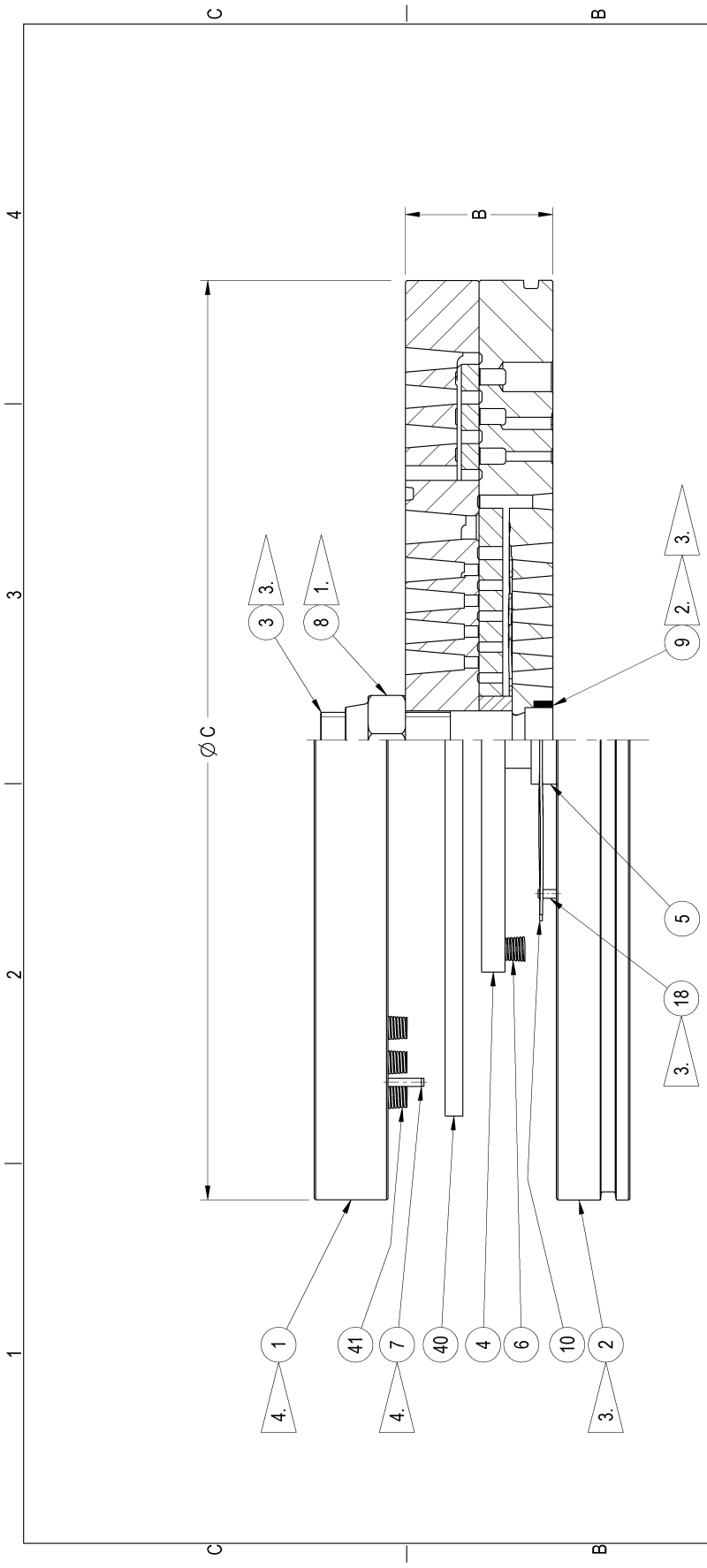
10-3/4P-HE PISTON, TFE RINGS

PART NO. G-18526  
REF DRAWING A-17849

ITEM	PART NUMBER	QTY	DESCRIPTION
1	C-5974	1	PISTON, , 10-3/4P-HE
2	A-17457	2	PISTON RING, 10-3/4P-HE
5	B-0019	1	PISTON NUT, 2-1/4" THROUGH 8" PISTONS, JG:A:M:P
6	FS0405BE	2	SET SCREW, CUP POINT, #10-32 X 3/4

WHEN A ZERO APPEARS IN THE QUANTITY COLUMN IT  
DOES NOT REPRESENT THE QUANTITY REQUIRED.


\*\*\* ALWAYS PROVIDE SERIAL NUMBER WHEN ORDERING SPARE PARTS. \*\*\*



**NOTES:**

- 1. SEE MANUAL FOR TORQUING VALUES (ITEM #8).
- 2. INSTALL PER ER-52.
- 3. LOWER PART ASSEMBLY (ITEM #2) CONSISTS OF LOWER PART, CENTER STUD (ITEM #3), DOWEL PIN (ITEM #9) AND SPIROL PIN (ITEM #18).
- 4. UPPER PART ASSEMBLY (ITEM #1) CONSISTS OF UPPER PART AND SPIROL PIN (ITEM #7).

THIS DOCUMENT AND CONTENTS THEREIN ARE PROPRIETARY TO ARIEL CORPORATION. ONLY BY WRITTEN CONSENT AND AGREED TERMS BY ARIEL CORPORATION GIVES THE RIGHT TO MANUFACTURE, BUT DOES NOT GRANT THE RIGHT TO DISCLOSE OR USE IN PART OR IN WHOLE INFORMATION CONTAINED IN DOCUMENT.  
DIMENSIONS ARE IN INCHES UNLESS OTHERWISE SPECIFIED.  
--- DO NOT SCALE DRAWING ---

 <b>ARIEL CORPORATION</b> 35 BLACKJACK ROAD MOUNT VERNON, OHIO 43050	
TITLE:	CONCENTRIC VALVE
MATERIAL:	PROCURED
DRAWN:	KSL 11/05/10
CHECKED:	DLI 12/17/10
SCALE:	NONE
REV	ECN
0	17066
DWG. No. <b>A-17491</b>	

REV	DESCRIPTION	INIT/DATE	1	2	3	4

8/01/12

PARTS LIST

0.0000=A  
1.9690=B  
12.323=C  
0.0870=LFT

PART NO. B-5840-GG  
REF DRAWING A-17491

ITEM	PART NUMBER	QTY	DESCRIPTION
1	A-17908-A	1	UPPER PART ASSY, CONCENTRIC VLV
2	A-17909-A	1	LOWER PART ASSY, CONCENTRIC VLV
3	A-17800	1	CENTER STUD, 3/4-16 X 3.898
4	A-15670	1	VALVE PLATE, 147CT, .315 THICK, PC
5	A-17910	1	GUIDE RING, 147CT/256CFS, .441THK
6	A-1344	32	SPRING (.354/.276 OD X .630 FREE LENGTH) GREEN, .026 WIRE DIAMETER
7	A-2039	2	SPIROL PIN, .118D X .591L
8	A-1462	1	LOCKNUT, DRAKE, 3/4-16
9	A-1481	1	DOWEL PIN, .150D X .323L
10	A-2858	1	WAFER PLATE.147CHT
18	A-2941	2	SPIROL PIN .118D X .787L
40	A-17487	1	VALVE PLATE, 256CFS, .315 THICK, PC
41	A-12064	16	SPRING (.354 OD X .669 FREE LENGTH) GREEN, .041 WIRE DIAMETER
99	KB-5840-GG	0	KIT, CONCENTRIC VALVE, 147CT/256CFS

WHEN A ZERO APPEARS IN THE QUANTITY COLUMN IT  
DOES NOT REPRESENT THE QUANTITY REQUIRED.

\*\*\* ALWAYS PROVIDE SERIAL NUMBER WHEN ORDERING SPARE PARTS. \*\*\*





8/01/12

PARTS LIST

VALVE REMOVAL TOOL FOR 10-3/4P-HE CLASS  
CYLINDER.

PART NO. G-18897  
REF DRAWING A-17801

ITEM	PART NUMBER	QTY	DESCRIPTION
1	A-17749	0	VALVE PULLER ASSEMBLY, 5/8-11
2	B-5807	0	VALVE PULLER BAR, 10-3/4P-HE
3	FN0451HD	0	HEX NUT,H/W,2H,5/8-11
4	FW0502IA	0	WASHER,5/8 STEEL
5	AB-5806	1	VALVE PULLER, 10-3/4P-HE

WHEN A ZERO APPEARS IN THE QUANTITY COLUMN IT  
DOES NOT REPRESENT THE QUANTITY REQUIRED.

\*\*\* ALWAYS PROVIDE SERIAL NUMBER WHEN ORDERING SPARE PARTS. \*\*\*



## **2ND STAGE CYLINDER**

**THIS PAGE LEFT INTENTIONALLY BLANK**

8/01/12

ARIEL CORPORATION  
SALES ORDER COVER SHEET

C/N: 001

RHCOVP02

SERIAL #: C-136421

PART: 5-1/2P CE      DESCRIPTION: 5-1/2" JGP CE CYLINDER CLASS

PART NUMBER	QTY	DESCRIPTION	DRAWING NO.
G-20733	1	CYLINDER ASSEMBLY, 5-1/2P-CE, STD, 525 MAWP	A-17825
G-18742	1	SUC VLV ASSY, 5-1/2P-CE	B-0144
G-18741	1	DIS VLV ASSY, 5-1/2P-CE	B-0145
G-18744	1	PISTON ASSEMBLY, 5-1/2P-CE0, STD	A-17850
B-5091-CC	1	SUCTION VALVE, 79CRE, MTX	A-9277
B-5092-N	1	DISCHARGE VALVE, 79CRE, PKX	A-9255



8/01/12

PARTS LIST

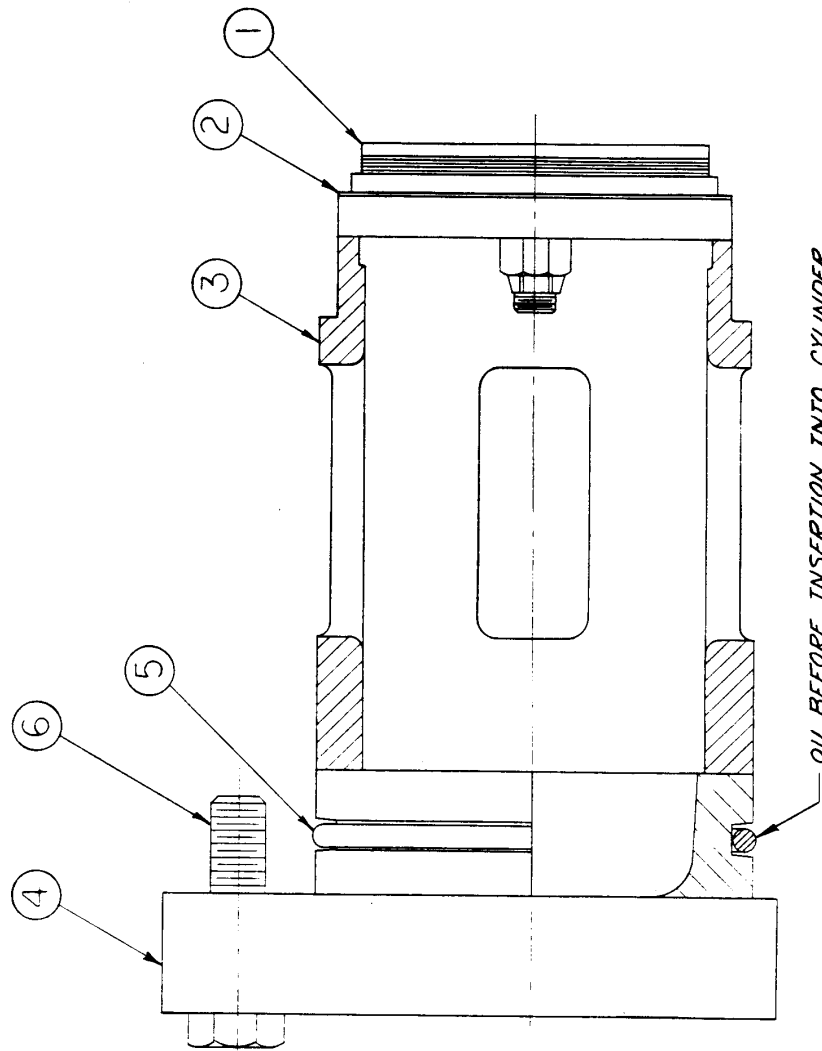
5-1/2" JGP-CE CYLINDER BODY & CRANK END      PART NO. G-20733  
HEAD, RDP 477#, MAWP 525#                      REF DRAWING A-17825

ITEM	PART NUMBER	QTY	DESCRIPTION
1	D-5915	0	CYLINDER, 5-1/2P-CE, 525 MAWP
2	C-5999	0	CRANK END HEAD, 5-1/2P-CE
3	A-17591	1	STEEL GASKET, 05.813 OD X 05.625 ID X .060, HEAD
4	FC0120GJ	6	12-POINT CAPSCREW, 1/2-13 X 1-3/4, G8
5	A-0065	1	FIBER GASKET, 12.000 OD X 09.015 ID X .015, CYLINDER TO DISTANCE PIECE, JG:M:P
6	FC0120GP	4	12-POINT CAPSCREW, 1/2-13 X 3-1/4, G8
12	PT0200CB	18."	TUBING, SS, 1/4 OD X .035 WALL
13	A-18496	1	CHECK VALVE, DOUBLE BALL, SS, 1/4 TUBE INLET X 1/8 NPT OUTLET,
16	A-0576	1	DATA PLATE, CYLINDER SPECIFICATION, 4 X 1-1/8
17	FR0571CC	8	DRIVE SCREW, TYPE U, SS, #6 X 1/4
18	PP0810GB	2	PIPE PLUG, HEX HEAD, 1/2 NPT, STL
19	A-0640-A	1	INFORMATION PLATE, SUCTION
20	A-0640-B	1	INFORMATION PLATE, DISCHARGE
29	A-17774	1	OIL TRAP, BODY, SS, 1/8 NPT
30	A-17776	1	OIL TRAP, STEM, SS, 1/4 NPT
48	FC0120GO	4	12-POINT CAPSCREW, 1/2-13 X 3, G8
77	A-3511	1	O-RING, VT, 10.395 OD X .210, 75/85 DUROMETER
100	HD-5915	1	CYLINDER HYDROTEST SET, 5-1/2P-CE, 525 MAWP

WHEN A ZERO APPEARS IN THE QUANTITY COLUMN IT  
DOES NOT REPRESENT THE QUANTITY REQUIRED.

\*\*\* ALWAYS PROVIDE SERIAL NUMBER WHEN ORDERING SPARE PARTS. \*\*\*





<b>ARIEL CORPORATION</b>	
MT. VERNON, OHIO	
SUCT. VALVE, RETAINER, CAP ASSY. 5 1/8" M CLASS	
MATERIAL	
DRAWN JEC 6-23-75	PART NO. B-144
CHECKED JFC 7-15-75	
SCALE	

8/01/12

PARTS LIST

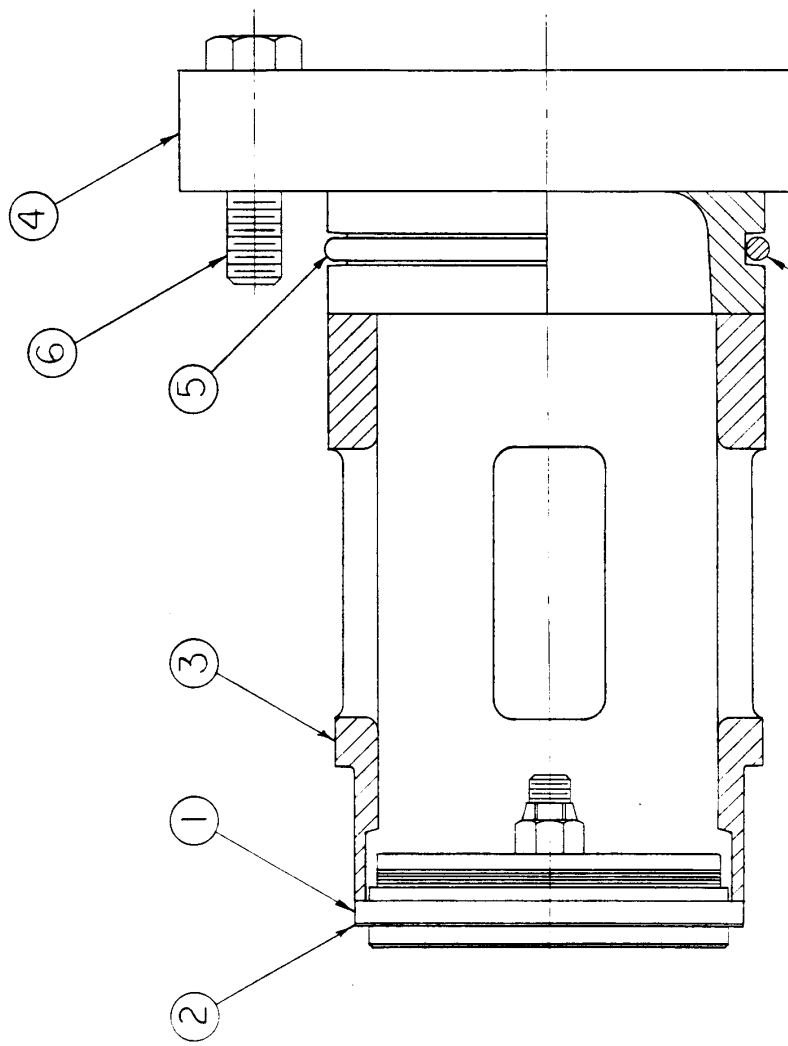
SUCTION VALVE, RETAINER AND CAP  
5-1/2P-CE CLASS

PART NO. G-18742  
REF DRAWING B-0144

ITEM	PART NUMBER	QTY	DESCRIPTION
1	SUCTION VALVE	0	FOR VALVE PART NUMBER, SEE COVER SHEET
2	A-15600	1	STEEL GASKET, 03.575 OD X 03.406 ID X .030, VALVE
3	B-5746	1	VLV RET,SUC, 5-1/2P-CE
4	B-5757	0	VALVE CAP, 5-1/2P-CE
5	A-0026	1	O-RING, VT, 3.895 OD X .210, 75/85 DUROMETER
6	FC0171CED	4	12-POINT CAPSCREW, 1/2-13 X 2 X 9/16, G8

WHEN A ZERO APPEARS IN THE QUANTITY COLUMN IT  
DOES NOT REPRESENT THE QUANTITY REQUIRED.

\*\*\* ALWAYS PROVIDE SERIAL NUMBER WHEN ORDERING SPARE PARTS. \*\*\*



**ARIEL CORPORATION**  
 MT. VERNON, OHIO

DISCH. VALVE, RETAINER CAP ASSY.  
 5/8" M CLASS

MATERIAL: \_\_\_\_\_

DRAWN: JEC 6-23-75 PART NO. B-145  
 CHECKED: JPB 7-13-75  
 SCALE: 1

OIL BEFORE INSERTION  
 INTO CYLINDER

8/01/12

PARTS LIST

DISCHARGE VALVE, RETAINER AND CAP  
5-1/2P-CE CLASS

PART NO. G-18741  
REF DRAWING B-0145

ITEM	PART NUMBER	QTY	DESCRIPTION
1	DISCHARGE VALV	0	FOR VALVE PART NUMBER, SEE COVER SHEET
2	A-15600	1	STEEL GASKET, 03.575 OD X 03.406 ID X .030, VALVE
3	B-5745	1	VLV RET,DIS, 5-1/2P-CE
4	B-5757	0	VALVE CAP, 5-1/2P-CE
5	A-0026	1	O-RING, VT, 3.895 OD X .210, 75/85 DUROMETER
6	FC0171CED	4	12-POINT CAPSCREW, 1/2-13 X 2 X 9/16, G8

WHEN A ZERO APPEARS IN THE QUANTITY COLUMN IT  
DOES NOT REPRESENT THE QUANTITY REQUIRED.

\*\*\* ALWAYS PROVIDE SERIAL NUMBER WHEN ORDERING SPARE PARTS. \*\*\*

1 2 3 4

**NOTES:**

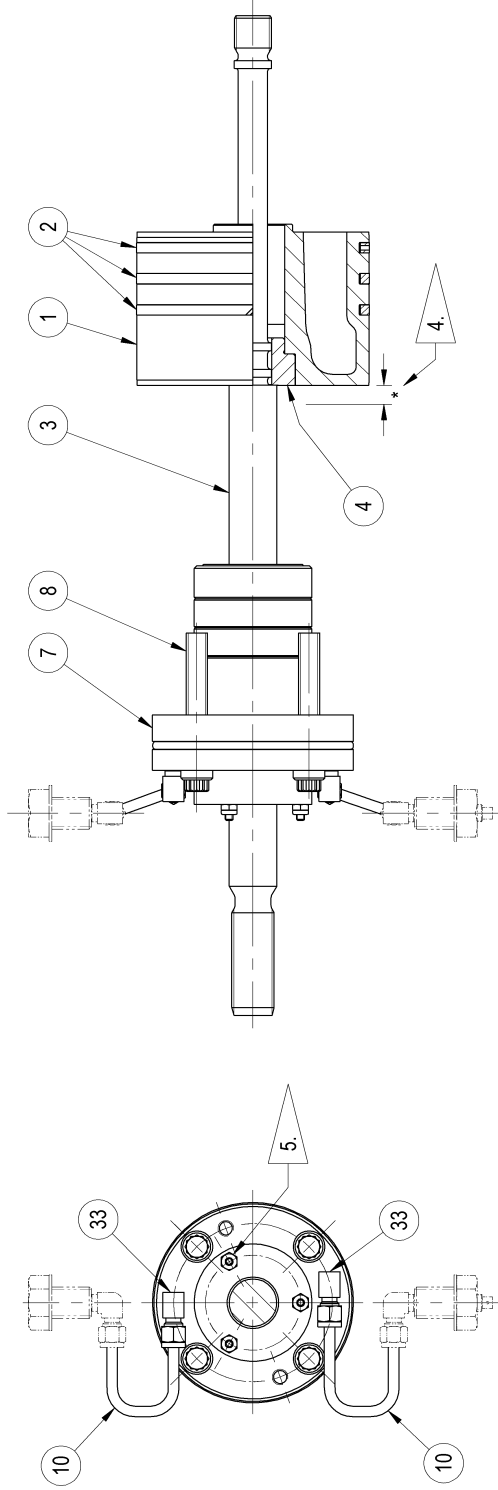
- 1.- THIS PISTON ASSEMBLY DRAWING IS FOR ILLUSTRATION PURPOSES ONLY AND MAY NOT NECESSARILY REPRESENT THE EXACT CONFIGURATION PERTAINING TO THE UNIT ORDERED. REFER TO ACCOMPANYING PARTS LIST FOR ITEMS (AND QUANTITIES OF EACH) REQUIRED FOR THIS PARTICULAR ASSEMBLY.
- 2.- REFER TO TECHNICAL MANUALS FOR RECOMMENDED PROCEDURES AND TORQUE VALUES FOR ASSEMBLY OR REASSEMBLY OF THIS UNIT.
- 3.- ASSEMBLE FITTINGS (ITEMS #33) BEFORE INSTALLING PACKING.



REMOVE ONE C.E. SUCTION VALVE TO ADJUST C.E. PISTON CLEARANCE (SEE CYLINDER SPECIFICATIONS DATA PLATE OR THE TECHNICAL MANUAL). **DO NOT USE STRAP WRENCH ON PISTON ROD**, USE TURNING TOOL WHICH FITS TURNING HOLES IN PISTON NUT.



RETIGHTEN TIE STUD NUTS AFTER PACKING CASE (ITEM #7) IS BOLTED TO CYLINDER.



A B C

**ARIEL CORPORATION**  
 35 BLACKJACK ROAD  
 MOUNT VERNON, OHIO 43050



ASSEMBLY  
 DWG. NO. **A-17850**  
 SHT 1 OF 1

REV	DESCRIPTION	INITIALS	DATE
0	17066	CPM 01/26/11	DLI 01/31/11
REV	EON	SCALE	NONE

THIS DOCUMENT AND CONTENTS THEREIN ARE PROPRIETARY TO ARIEL CORPORATION. ONLY BY WRITTEN CONSENT AND AGREED TERMS BY ARIEL CORPORATION GIVES THE RIGHT TO DISCLOSE OR USE IN PART OR IN WHOLE INFORMATION CONTAINED IN DOCUMENT.

REV	DESCRIPTION	INITIALS	DATE
0	17066	CPM 01/26/11	DLI 01/31/11
REV	EON	SCALE	NONE

1 2 3 4

8/01/12

PARTS LIST

5-1/2" JGP-CE0 PIST, TFE RINGS,TFE PKG  
3" STROKE

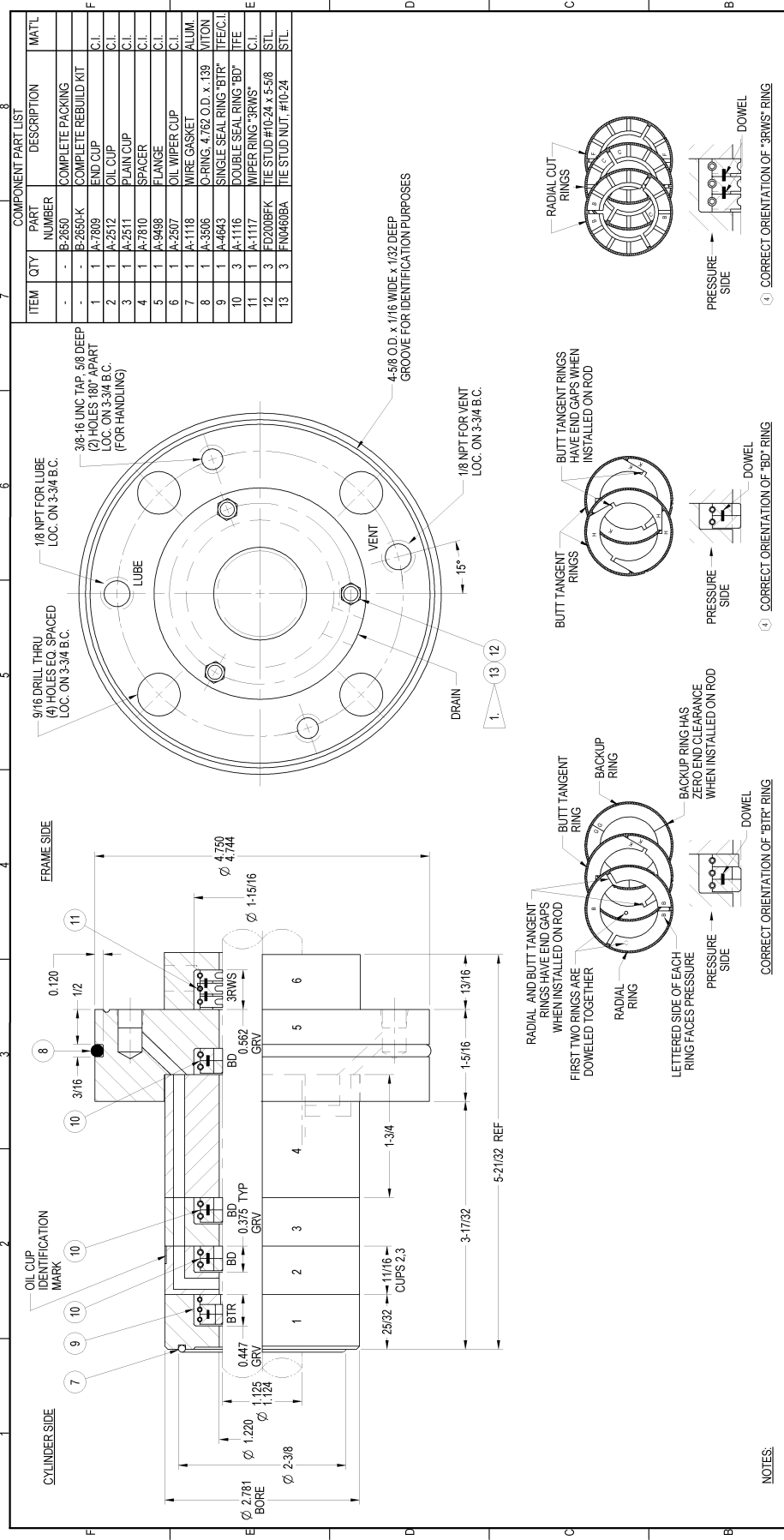
PART NO. G-18744  
REF DRAWING A-17850

ITEM	PART NUMBER	QTY	DESCRIPTION
1	C-6000	1	PIST, , 5-1/2P0-CE
2	A-0237	3	PISTON RING, 5-1/2R:M:P:H:RJ
3	C-6001	1	PISTON ROD, 3.000 STROKE / 23.689 LONG
4	A-0057	1	PISTON COLLAR, 2-1/2" THROUGH 8" PISTONS, JG:M:P
7	B-2650	1	PKG,1.125, 600
8	FC0120GP	4	12-POINT CAPSCREW, 1/2-13 X 3-1/4, G8
10	PT0200CB	18."	TUBING, SS, 1/4 OD X .035 WALL
33	A-0815	0	MALE ELBOW, STL, 1/4 TUBE X 1/8 NPT
99	B-2650-K	0	REBUILD KIT, 1.125 PISTON ROD PACKING

WHEN A ZERO APPEARS IN THE QUANTITY COLUMN IT  
DOES NOT REPRESENT THE QUANTITY REQUIRED.

\*\*\* ALWAYS PROVIDE SERIAL NUMBER WHEN ORDERING SPARE PARTS. \*\*\*





ITEM	QTY	PART NUMBER	DESCRIPTION	MAT'L
-	-	B-2650	COMPLETE PACKING	
-	-	B-2650-K	COMPLETE REBUILD KIT	
1	1	A-7809	END CUP	C.I.
2	1	A-2512	OIL CUP	C.I.
3	1	A-2511	PLAIN CUP	C.I.
4	1	A-7810	SPACER	C.I.
5	1	A-9488	FLANGE	C.I.
6	1	A-2507	OIL WIPER CUP	C.I.
7	1	A-1118	WIRE GASKET	ALUM.
8	1	A-3506	O-RING 4.762 O.D. x .139	MITON
9	1	A-4643	SINGLE SEAL RING "BTR"	TFE/C.I.
10	3	A-1116	DOUBLE SEAL RING "BD"	TFE
11	1	A-1117	WIPER RING "3RWS"	C.I.
12	3	FD208FK	TIE STUD #10-24 x 5-5/8	STL.
13	3	FN0468A	TIE STUD NUT #10-24	STL.

<b>ARIEL CORPORATION</b> 35 BLACKJACK ROAD MOUNT VERNON, OHIO 43050		TITLE <b>ROD PACKING, 1.125 VAC - 600 PSI</b>
DRAWN <b>IG 11/11/99</b>	MATERIAL <b>SEE TABULATION</b>	P.C. No. <b>CB-2650</b>
CHECKED <b>CAH 11/16/99</b>	SCALE <b>NONE</b>	PART No. <b>B-2650</b>
THIS DOCUMENT HAS CONTENTS THAT ARE PROPRIETARY TO ARIEL CORPORATION. ONLY BY WRITTEN CONSENT AND AGREED TERMS BY ARIEL CORPORATION OVERS THE RIGHT TO MANUFACTURE, BUT DOES NOT CONSTITUTE AN ENDORSEMENT OR A GUARANTEE OF PERFORMANCE. INFORMATION CONTAINED IN DOCUMENT IS UNCLASSIFIED. DIMENSIONS ARE IN INCHES UNLESS OTHERWISE SPECIFIED. — DO NOT SCALE DRAWING —		SHIT 1 OF 1

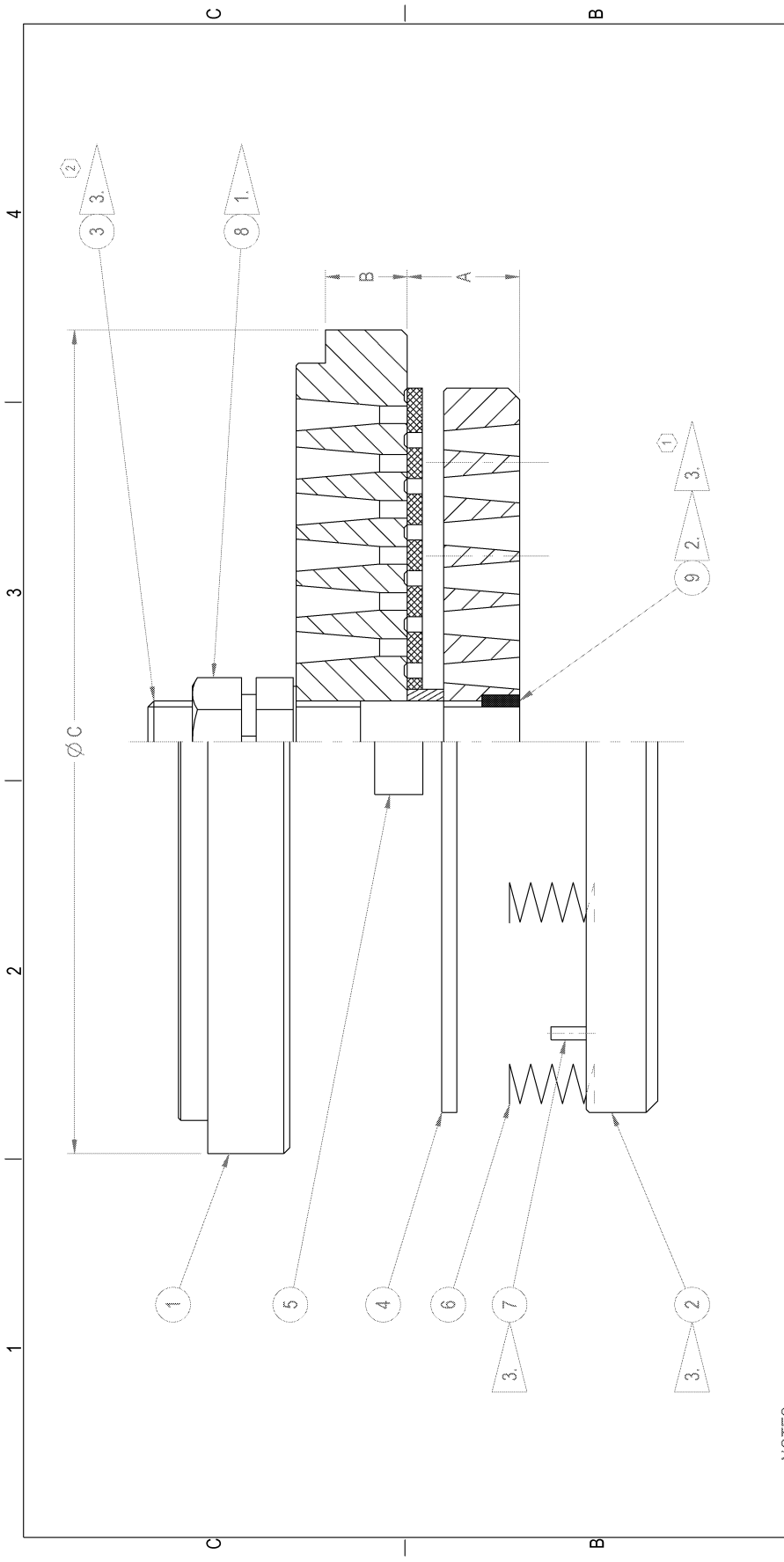
REV	DESCRIPTION	DATE
4	REPAIR TO SOLID EDGE - UPDATED ITEM NOTATION & ORIENTATION TO MATCH CURRENT VENDOR DRAWING. ADDED CORRECT ORIENTATION OF "BD" RING AND "3RWS" RING VIEWS. IN TITLE BLOCK. 800 PSI WAS 500 PSI.	02/21/11
3		
2		
1		
0		
10088		
14000		
17138		

**NOTES:**

- TIE STUD NUTS (ITEM #13) MUST BE LOCKNUTS. RETIGHTEN AFTER CASE IS BOLTED INTO STUFFING BOX.
- MATCHMARK LETTERS ON RINGS TO FACE COMPRESSOR PISTON.





**NOTES:**

- 1. SEE MANUAL FOR TORQUE VALUES (ITEM 8).
- 2. INSTALL PER E-52.
- 3. VALVE GUARD ASSEMBLY (ITEM 2) CONSISTS OF VALVE GUARD, CENTER STUD (ITEM 3), SPIROL PIN (ITEM 7) AND DOWL PIN (ITEM 9).

**ARIEL CORPORATION**  
 35 BLACKJACK ROAD  
 MOUNT VERNON, OHIO 43050

TITLE		SUCTION VALVE, CRE ①	
MATERIAL		PROCURED	
2	17410	DRAWN	IG 04/30/99
1	17350	CHECKED	ED 10/14/99
0	7796	SCALE	NONE
REV	ECN	DWG No	A-9277

THIS DOCUMENT AND CONTENTS THEREIN ARE PROPRIETARY TO ARIEL CORPORATION. ONLY BY WRITTEN CONSENT AND AGREED TERMS BY ARIEL CORPORATION GIVES THE RIGHT TO MANUFACTURE, BUT DOES NOT GRANT THE RIGHT TO DISCLOSE OR USE IN PART OR IN WHOLE INFORMATION CONTAINED IN DOCUMENT.  
 DIMENSIONS ARE IN INCHES UNLESS OTHERWISE SPECIFIED.  
 --- DO NOT SCALE DRAWING ---

2	AT C4 FLAG 3 WAS FLAG 2.	MLB	02/28/11
1	UPDATED TO SOLID EDGE. AT B3 ADDED FLAG 3. IN TITLE BLOCK CRE WAS CRO.	MLB	02/07/11
REV	DESCRIPTION	INIT/DATE	

8/20/12

PARTS LIST

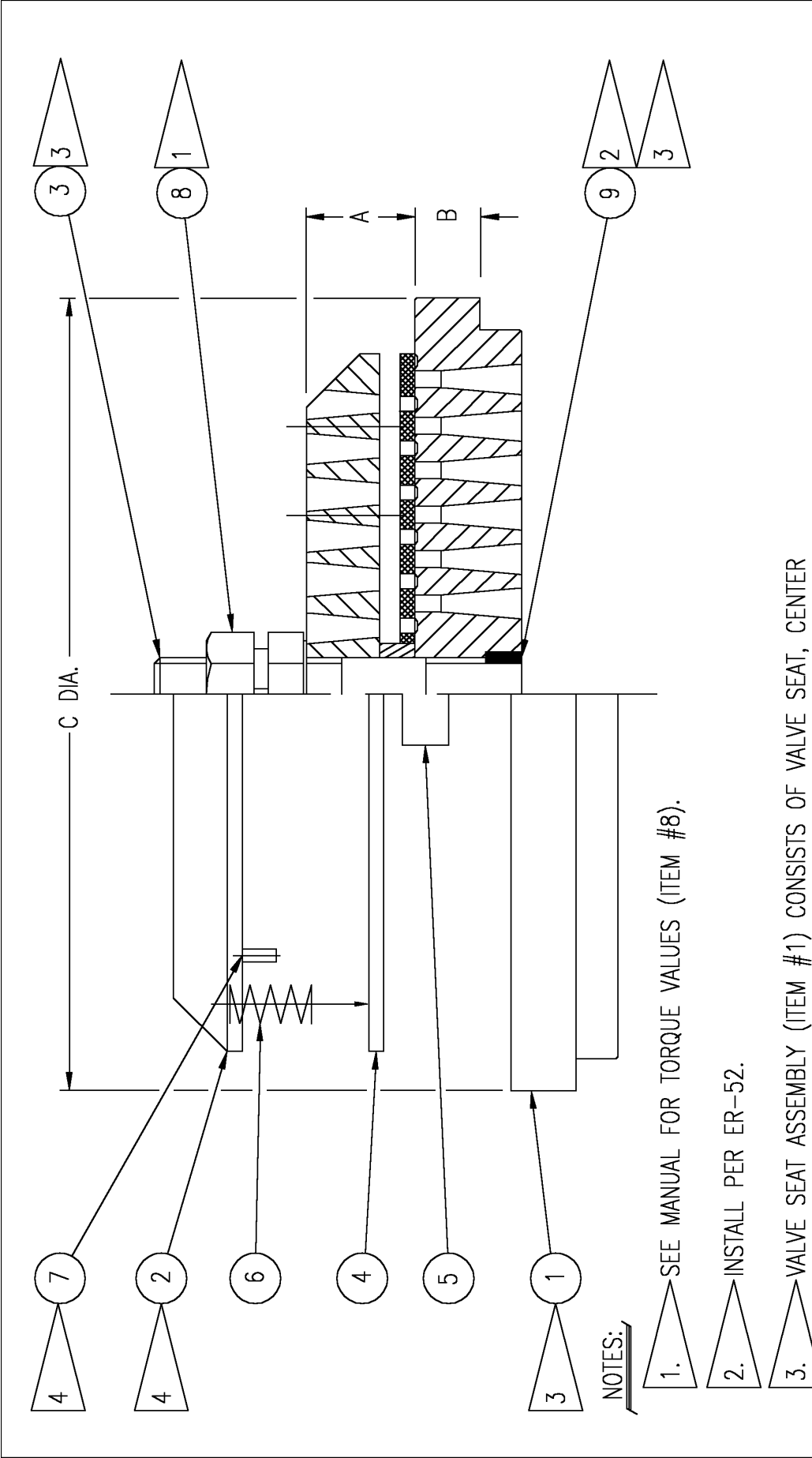
0.6180=A  
0.6420=B  
3.5800=C  
0.0470=LFT

PART NO. B-5091-CC  
REF DRAWING A-9277

ITEM NUMBER	PART NUMBER	QUANTITY	DESCRIPTION
001	A-15639	1	SUC VLV SEAT, 79CRE
002	A-19954-A	1	SUC VLV GUARD ASSY, 79CRE
003	A-2669	1	CNTR STUD, 3/8-24 X 2.28
004	A-15637	1	VLV PLT, 79CRE.157THK,MTX
005	A-1735	1	GUIDE RING, 70RX, .205 THK
006	A-8898	9	SPRING(.197DX.413 BLUE).024
007	A-1023	2	SPIROL PIN, .091D X .433L
008	A-1367	1	LOCKNUT, DRAKE 3/8-24
009	A-16466	1	LOCK, STUD .098D
099	KB-5091-CC	0	KIT, VLV, 79CRE, MTX

WHEN A ZERO APPEARS IN THE QUANTITY COLUMN IT  
DOES NOT REPRESENT THE QUANTITY REQUIRED.

\*\*\*\*\*  
\*\*\*\* ALWAYS PROVIDE SERIAL NUMBER WHEN ORDERING SPARE PARTS. \*\*\*\*  
\*\*\*\*\*



**NOTES:**

1. SEE MANUAL FOR TORQUE VALUES (ITEM #8).
2. INSTALL PER ER-52.
3. VALVE SEAT ASSEMBLY (ITEM #1) CONSISTS OF VALVE SEAT, CENTER STUD (ITEM #3), AND DOWEL PIN (ITEM #9).
4. VALVE GUARD ASSEMBLY (ITEM #2) CONSISTS OF VALVE GUARD, AND SPIROL PINS (ITEM #7).

**ARIEL CORPORATION**  
 35 BLACKJACK ROAD  
 MOUNT VERNON, OHIO 43050

TITLE:	DISCHARGE VALVE, CRO
MATERIAL:	PROCURED
DRAWN:	IG 9/24/99
CHECKED:	ED 10/4/99
R.S. No.	
PART NO.	
SCALE:	NONE
DWG. No.	A-9255

THIS DOCUMENT AND CONTENTS THEREIN ARE PROPRIETARY TO ARIEL CORPORATION. ONLY BY WRITTEN CONSENT AND AGREED TERMS BY ARIEL CORPORATION GIVES THE RIGHT TO MANUFACTURE, BUT DOES NOT GRANT THE RIGHT TO DISCLOSE OR USE IN PART OR IN WHOLE INFORMATION CONTAINED IN DOCUMENT.

DIMENSIONS ARE IN INCHES UNLESS OTHERWISE SPECIFIED.  
 ---- DO NOT SCALE DRAWING ----  
 DIMENSIONING AND TOLERANCING PER ARIEL SPECIFICATION ER-17.0.1 UNLESS OTHERWISE SPECIFIED.

REV	DESCRIPTION
0	7799
	ECN





# **3RD STAGE CYLINDER**

**THIS PAGE LEFT INTENTIONALLY BLANK**

8/01/12

ARIEL CORPORATION  
SALES ORDER COVER SHEET

C/N: 001

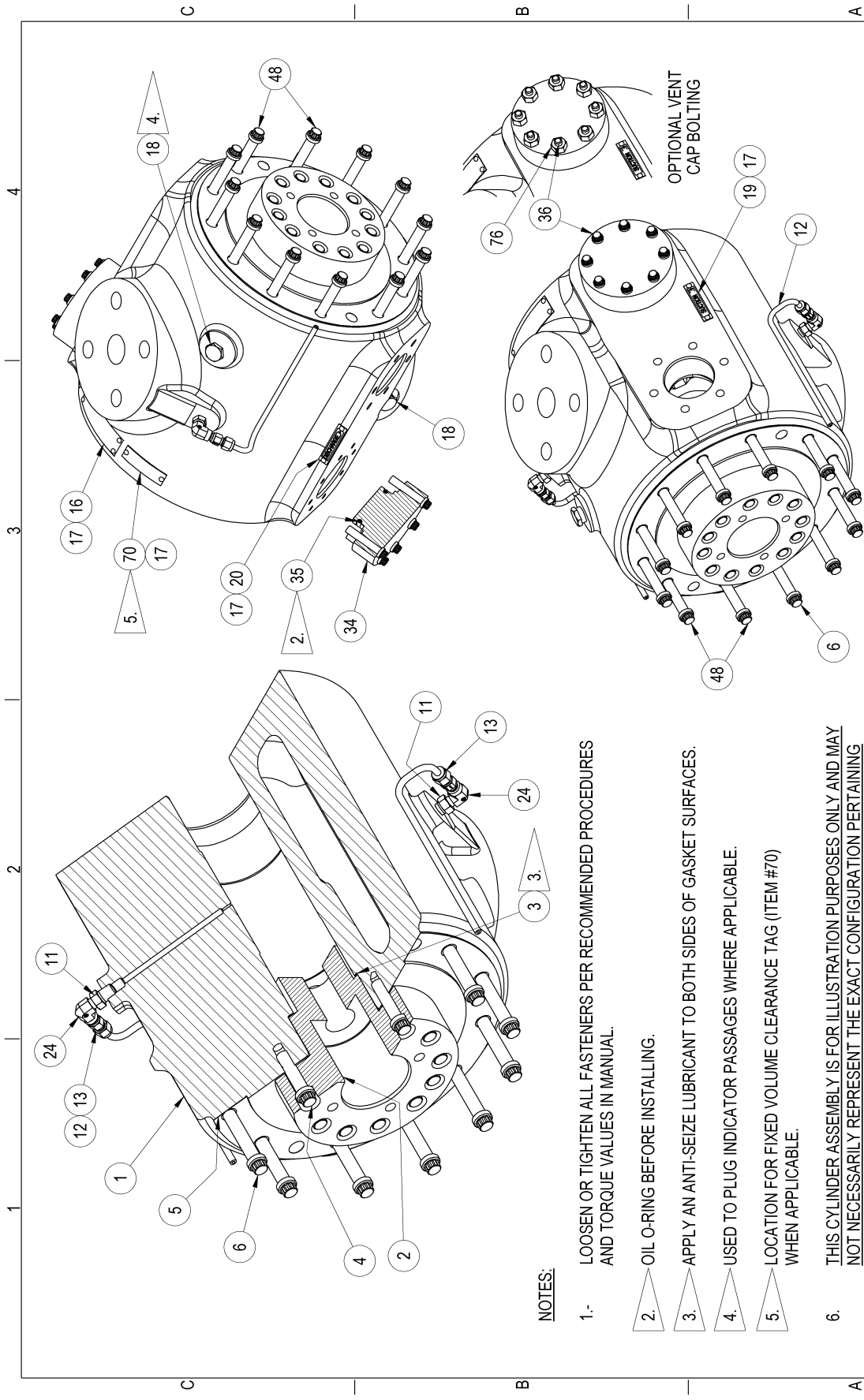
RHCOVP02

SERIAL #: C-136419

PART: 3-3/4SG CE      DESCRIPTION: 3-3/4SG-CE CYLINDER CLASS

PART NUMBER	QTY	DESCRIPTION	DRAWING NO.
G-20735	1	CYLINDER ASSEMBLY, 3-3/4SG-CE, 2550 MAWP	A-18942
G-19022	1	SUCTION VALVE ASSEMBLY, 3-3/4SG-CE	A-6267
G-19023	1	DISCHARGE VALVE ASSEMBLY, 3-3/4SG-CE	A-6267
G-21088	1	PISTON ASSEMBLY, 3.750 X 1.625SA, 3" STROKE	A-19529
B-4087-BB	1	SUC VLV, 52RX ,MTX	A-9251
B-3712-M	1	DIS VLV, 52RX ,PKX	A-9208





**NOTES:**

- 1.- LOOSEN OR TIGHTEN ALL FASTENERS PER RECOMMENDED PROCEDURES AND TORQUE VALUES IN MANUAL.
2. OIL O-RING BEFORE INSTALLING.
3. APPLY AN ANTI-SEIZE LUBRICANT TO BOTH SIDES OF GASKET SURFACES.
4. USED TO PLUG INDICATOR PASSAGES WHERE APPLICABLE.
5. LOCATION FOR FIXED VOLUME CLEARANCE TAG (ITEM #70) WHEN APPLICABLE.
6. THIS CYLINDER ASSEMBLY IS FOR ILLUSTRATION PURPOSES ONLY AND MAY NOT NECESSARILY REPRESENT THE EXACT CONFIGURATION PERTAINING TO THE UNIT ORDERED. REFER TO ACCOMPANYING PARTS LIST FOR ITEMS (AND QUANTITIES OF EACH) REQUIRED FOR THIS PARTICULAR ASSEMBLY.

**ARIEL CORPORATION**  
 35 BLACKJACK ROAD  
 MOUNT VERNON, OHIO 43050



ASSEMBLY  
 DWG. NO. **A-18942**  
 SHT 1 OF 1

REV	DESCRIPTION	INITIALS	DATE

REV	EON	REV	EON	REV	EON	REV	EON

REV	DESCRIPTION	INITIALS	DATE

REV	DESCRIPTION	INITIALS	DATE

THIS DOCUMENT AND CONTENTS THEREIN ARE PROPRIETARY TO ARIEL CORPORATION. ONLY BY WRITTEN CONSENT AND AGREED TERMS BY ARIEL CORPORATION GIVES THE RIGHT TO DISCLOSE OR USE IN PART OR IN WHOLE INFORMATION CONTAINED IN DOCUMENT.

8/01/12

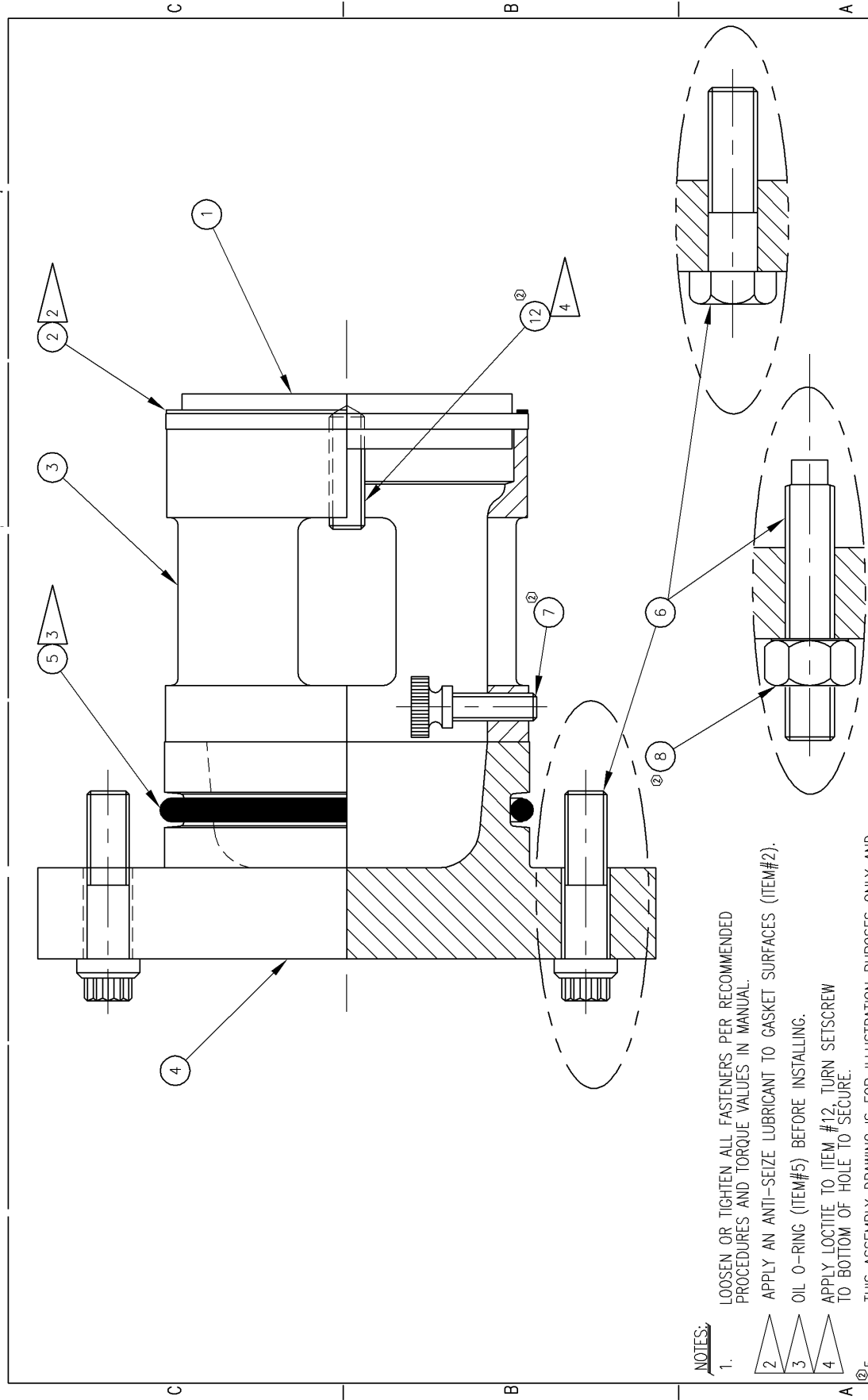
PARTS LIST

3-3/4"SG-CE TANDEM CYLINDER BODY, CRANK PART NO. G-20735  
END HEAD AND VENT CAP. REF DRAWING A-18942  
RDP 2318#, MAWP 2550#

ITEM	PART NUMBER	QTY	DESCRIPTION
1	D-5950	0	CYLINDER, 3-3/4SG-CE, 2550 MAWP
2	C-6157	0	CRANK END HEAD, 3-3/4SG-CE:SA-CE
3	A-13933	1	STEEL GASKET, 04.000 OD X 03.813 ID X .060, HEAD
4	FC0120GK	12	12-POINT CAPSCREW, 1/2-13 X 2, G8
5	A-0065	1	FIBER GASKET,12.000 OD X 09.015 ID X .015, CYLINDER TO DISTANCE PIECE,JG:M:P
6	FC0120GP	8	12-POINT CAPSCREW, 1/2-13 X 3-1/4, G8
11	A-0811	1	HEX REDUCING BUSHING, 1/4 NPT (MALE) X 1/8 NPT (FEMALE), STL
12	PT0201CD	27."	TUBING, 316 SS, 1/4 OD X .065 WALL
13	A-18496	1	CHECK VALVE, DOUBLE BALL, SS, 1/4 TUBE INLET X 1/8 NPT OUTLET,
16	A-0576	1	DATA PLATE, CYLINDER SPECIFICATION, 4 X 1-1/8
17	FR0571CC	8	DRIVE SCREW, TYPE U, SS, #6 X 1/4
18	PP0810GB	2	PIPE PLUG, HEX HEAD, 1/2 NPT, STL
19	A-0640-A	1	INFORMATION PLATE, SUCTION
20	A-0640-B	1	INFORMATION PLATE, DISCHARGE
24	A-0804	1	STREET ELBOW, 90° $\frac{1}{2}$ , 1/8 NPT, STL
34	B-4305	0	VENT CAP,3&3-5/8SG-CE CL
35	A-0027	2	O-RING, VT, 2.520 OD X .210, 75/85 DUROMETER
36	FC0120EK	16	12-POINT CAPSCREW, 3/8-16 X 2, G8
48	FC0120GO	4	12-POINT CAPSCREW, 1/2-13 X 3, G8
100	HD-6099	1	CYLINDER HYDROTEST SET, 3-3/4SG-CE:SA-CE, 2550 MAWP

WHEN A ZERO APPEARS IN THE QUANTITY COLUMN IT  
DOES NOT REPRESENT THE QUANTITY REQUIRED.

\*\*\* ALWAYS PROVIDE SERIAL NUMBER WHEN ORDERING SPARE PARTS. \*\*\*



**NOTES:**

1. LOOSEN OR TIGHTEN ALL FASTENERS PER RECOMMENDED PROCEDURES AND TORQUE VALUES IN MANUAL.
2. APPLY AN ANTI-SEIZE LUBRICANT TO GASKET SURFACES (ITEM#2).
3. OIL O-RING (ITEM#5) BEFORE INSTALLING.
4. APPLY LOCTITE TO ITEM #12, TURN SETSCREW TO BOTTOM OF HOLE TO SECURE.
5. THIS ASSEMBLY DRAWING IS FOR ILLUSTRATION PURPOSES ONLY AND MAY NOT NECESSARILY REPRESENT THE EXACT CONFIGURATION PERTAINING TO THE UNIT ORDERED. REFER TO THE ACCOMPANYING PARTS LIST FOR ITEMS (AND QUANTITIES OF EACH) REQUIRED FOR THIS ASSEMBLY.

REV	DESCRIPTION	INIT/DATE
②	REVISIONS: ① ADDED ITEM #5 WAS "MAY NOT APPLY TO ALL ASSEMBLIES."	JCS 9/30/02

THIS DOCUMENT AND CONTENTS THEREIN ARE PROPRIETARY TO ARIEL CORPORATION. ONLY BY WRITTEN CONSENT AND AGREED TERMS BY ARIEL CORPORATION GIVES THE RIGHT TO MANUFACTURE, BUT DOES NOT GRANT ANY OTHER RIGHTS OR USE IN PART OR IN WHOLE INFORMATION CONTAINED IN DOCUMENT.

2	10873	ECN	REV	3
1	10217	ECN	REV	3
0	6157	ECN	REV	3
DRAWN: CAH 3/28/96		APPROVED: NONE		
CHECKER: 4/11/96		SCALE: NONE		

**ARIEL CORPORATION**  
 35 BLACKJACK ROAD  
 MOUNT VERNON, OHIO 43050



ASSEMBLY DWG. NO. **A-6267**

8/01/12

PARTS LIST

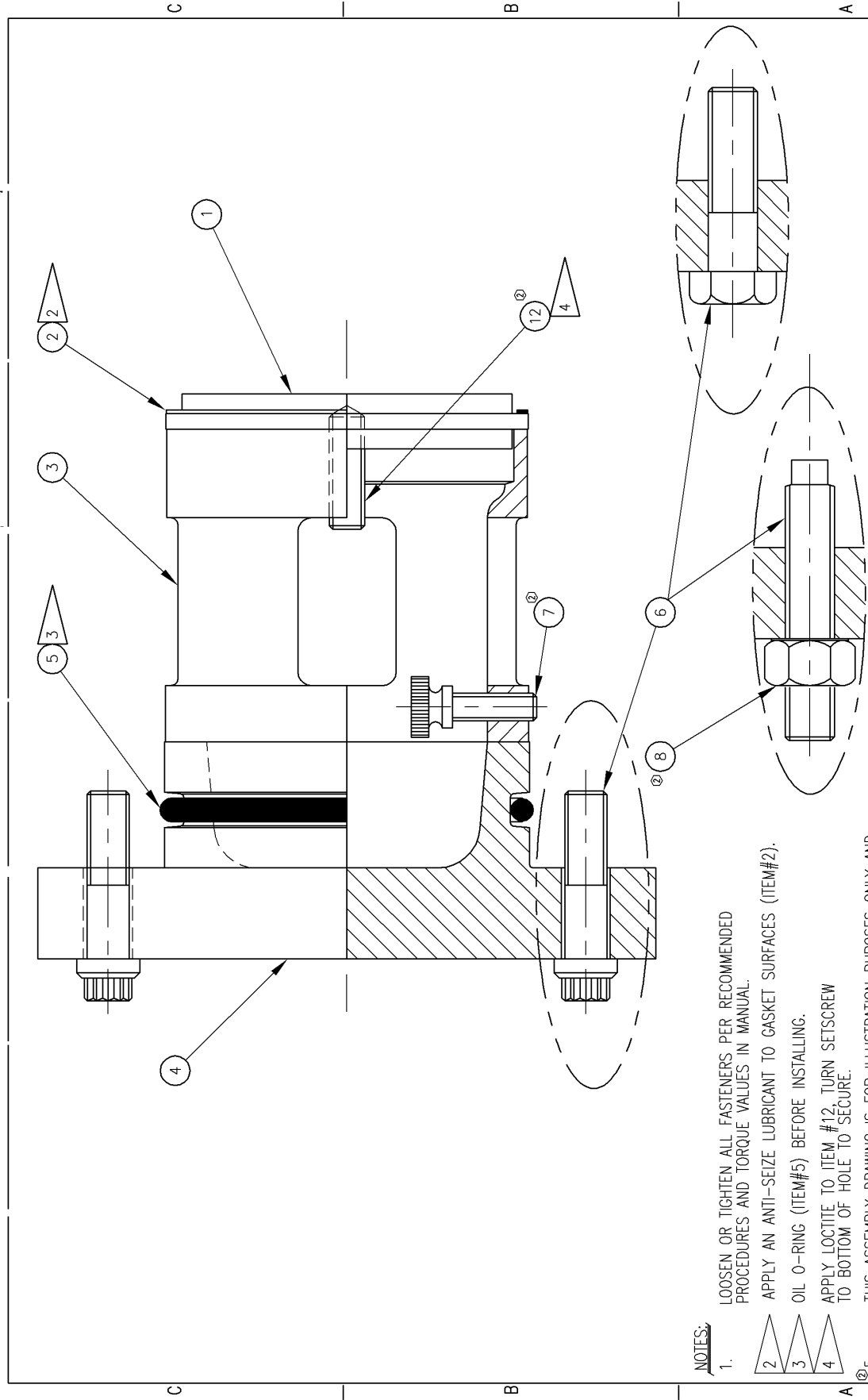
SUCTION VALVE, RETAINER AND CAP  
3-3/4SG:A-CE CYLINDER CLASS

PART NO. G-19022  
REF DRAWING A-6267

ITEM	PART NUMBER	QTY	DESCRIPTION
1	SUCTION VALVE	0	FOR VALVE PART NUMBER, SEE COVER SHEET
2	A-13192	1	STEEL GASKET, 02.438 OD X 02.250 ID X .060, VALVE
3	B-5826	1	VLV RET,SUC, 3-3/4SG-CE CL
4	B-3411	0	VALVE CAP, 3SG-CE:SG-CE HP:SG-CE HP PRC, 3-5/8SG-CE:SG-CE HP & 3-3/4SG CE
5	A-0027	1	O-RING, VT, 2.520 OD X .210, 75/85 DUROMETER
6	FC0171CFD	6	12-POINT CAPSCREW, 1/2-13 X 2-1/4 X 9/16, G8

WHEN A ZERO APPEARS IN THE QUANTITY COLUMN IT  
DOES NOT REPRESENT THE QUANTITY REQUIRED.

\*\*\* ALWAYS PROVIDE SERIAL NUMBER WHEN ORDERING SPARE PARTS. \*\*\*



**NOTES:**

1. LOOSEN OR TIGHTEN ALL FASTENERS PER RECOMMENDED PROCEDURES AND TORQUE VALUES IN MANUAL.
2. APPLY AN ANTI-SEIZE LUBRICANT TO GASKET SURFACES (ITEM#2).
3. OIL O-RING (ITEM#5) BEFORE INSTALLING.
4. APPLY LOCTITE TO ITEM #12, TURN SETSCREW TO BOTTOM OF HOLE TO SECURE.
5. THIS ASSEMBLY DRAWING IS FOR ILLUSTRATION PURPOSES ONLY AND MAY NOT NECESSARILY REPRESENT THE EXACT CONFIGURATION PERTAINING TO THE UNIT ORDERED. REFER TO THE ACCOMPANYING PARTS LIST FOR ITEMS (AND QUANTITIES OF EACH) REQUIRED FOR THIS ASSEMBLY.

REV	DESCRIPTION	INIT/DATE
1		CS 9/30/02
2	REVISIONS LISTED IN "TO CURRENT ITEM" ROTATION. ADVISORY NOT CAPTURED AND STUDY AND REVISED NOTE #5 WAS "MAY NOT APPLY TO ALL ASSEMBLIES." ADDED ITEM #6 (UNIT)	

2	10873	ECN	3
1	10217	ECN	3
0	6157	REV	3
DRAWN: CAH 3/28/96		APPROVED:	SCALE: NONE
CHECKER: 4/11/96		ASSEMBLY DWG. NO. A-6267	

**ARIEL CORPORATION**  
 35 BLACKJACK ROAD  
 MOUNT VERNON, OHIO 43050



8/01/12

PARTS LIST

DISCHARGE VALVE, RETAINER AND CAP  
3-3/4SG:A-CE CYLINDER CLASS

PART NO. G-19023  
REF DRAWING A-6267

ITEM	PART NUMBER	QTY	DESCRIPTION
1	DISCHARGE VALV	0	FOR VALVE PART NUMBER, SEE COVER SHEET
2	A-13192	1	STEEL GASKET, 02.438 OD X 02.250 ID X .060, VALVE
3	B-5827	1	VALVE RETAINER, DIS, 3-3/4SG-CE CL
4	B-3411	0	VALVE CAP, 3SG-CE:SG-CE HP:SG-CE HP PRC, 3-5/8SG-CE:SG-CE HP & 3-3/4SG CE
5	A-0027	1	O-RING, VT, 2.520 OD X .210, 75/85 DUROMETER
6	FC0171CFD	6	12-POINT CAPSCREW, 1/2-13 X 2-1/4 X 9/16, G8
7	A-3250	1	THUMB SCREW, NYLON, 1/4-20 X 1/2

WHEN A ZERO APPEARS IN THE QUANTITY COLUMN IT  
DOES NOT REPRESENT THE QUANTITY REQUIRED.

\*\*\* ALWAYS PROVIDE SERIAL NUMBER WHEN ORDERING SPARE PARTS. \*\*\*



8/01/12

PARTS LIST

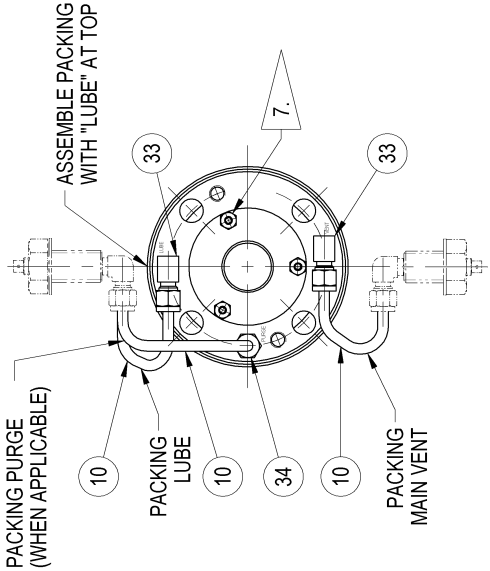
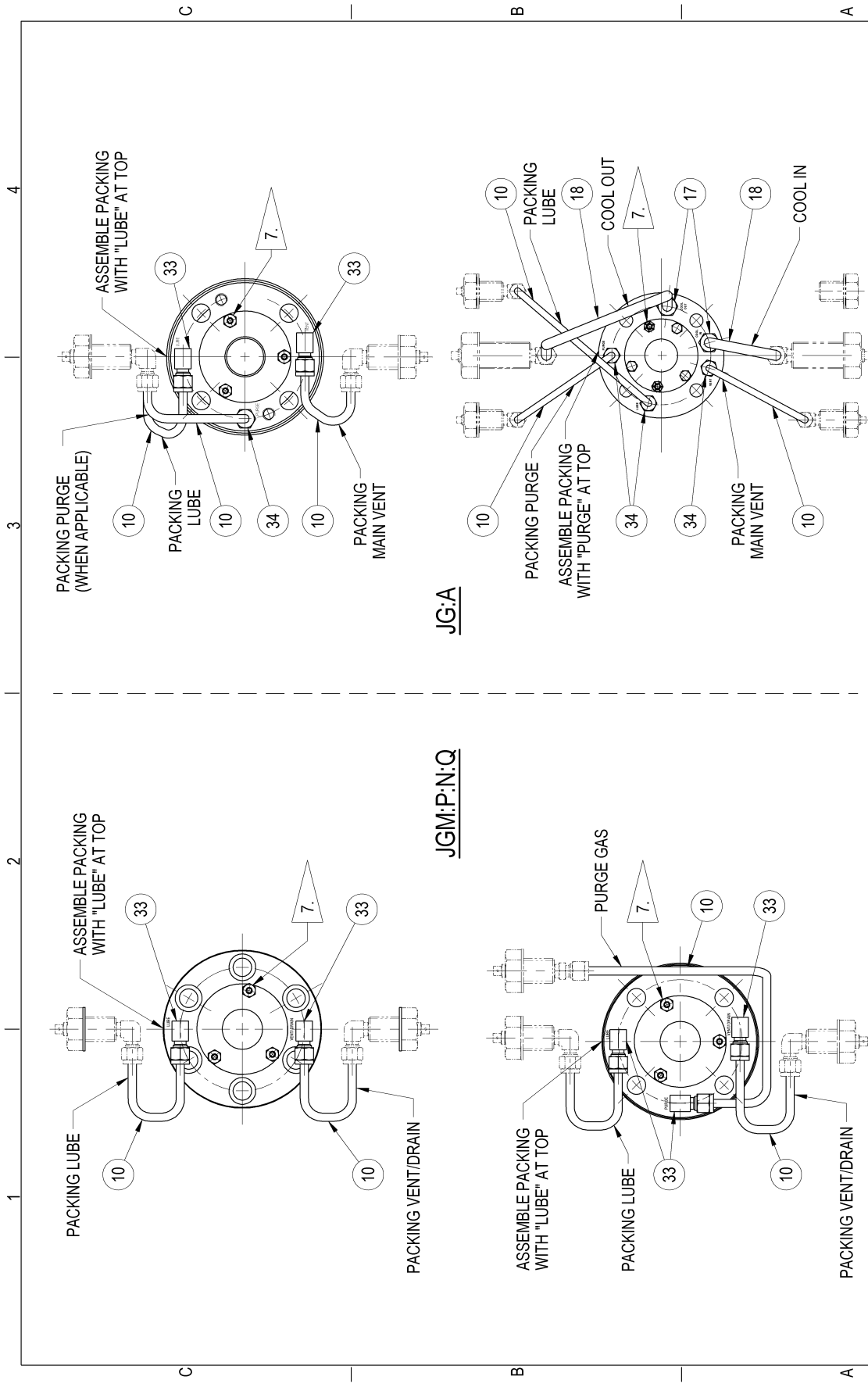
3-3/4" X 1-5/8" SA TANDEM PISTON/ROD, PART NO. G-21088  
3-3/4" RIDER RINGS, 1-1/8" BTR.ROD REF DRAWING A-19529 2 SHT  
PACKING, 1-5/8" TFE WEAR BAND & PEEK  
PISTON RINGS. 3" STROKE.

ITEM	PART NUMBER	QTY	DESCRIPTION
1	C-6029	1	PIST/ROD, 3.750 X 1.625SA
2	A-17854	4	RIDER RING, 3-3/4SG,SJ
7	B-2648	1	PKG,1.125,2550,STD
8	FC0120GL	4	12-POINT CAPSCREW, 1/2-13 X 2-1/4, G8
10	PT0201CD	12."	TUBING, 316 SS, 1/4 OD X .065 WALL
33	A-0815	0	MALE ELBOW, STL, 1/4 TUBE X 1/8 NPT
46	A-7266	2	PISTON RING, 1-5/8JG:SG,PK,SJ
47	A-7265	1	WEAR BAND, 1-5/8JG:SG,.875W
60	A-19365	4	PISTON RING, 1-5/8SG, PK
98	A-1678	1	PISTON NUT SPANNER,SPECIAL
99	B-2648-K	0	REBUILD KIT, 1.125 PISTON ROD PACKING

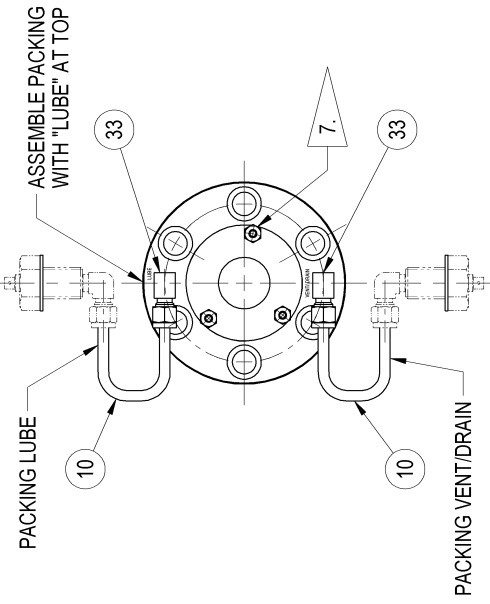
WHEN A ZERO APPEARS IN THE QUANTITY COLUMN IT  
DOES NOT REPRESENT THE QUANTITY REQUIRED.

\*\*\* ALWAYS PROVIDE SERIAL NUMBER WHEN ORDERING SPARE PARTS. \*\*\*

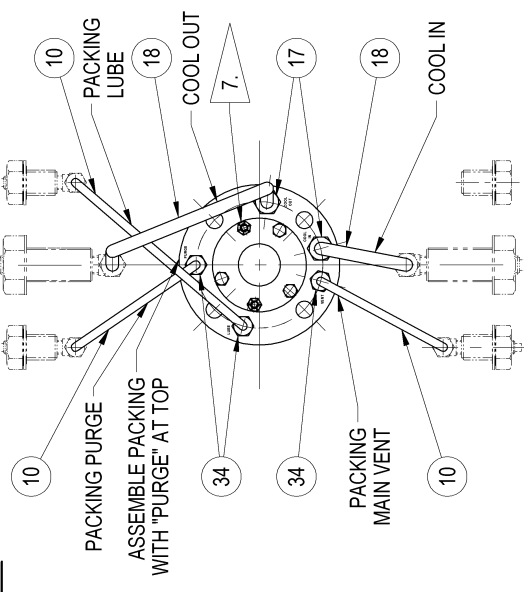




JG:A



JGM:P:N:Q



REV	DESCRIPTION	INITIALS
1		
2		

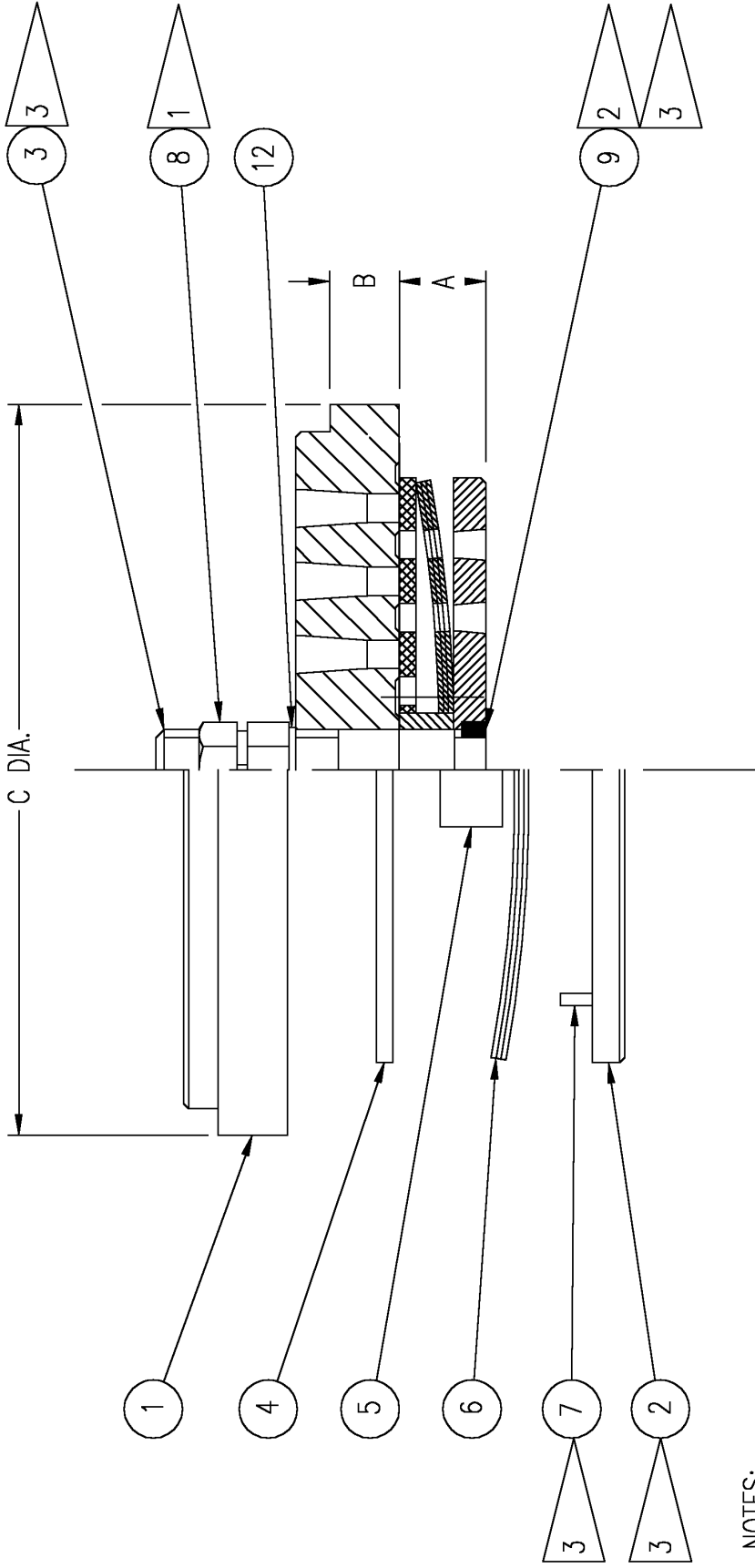
THIS DOCUMENT AND CONTENTS THEREIN ARE PROPRIETARY TO ARIEL CORPORATION. ONLY BY WRITTEN CONSENT AND AGREED TERMS BY ARIEL CORPORATION GIVES THE RIGHT TO DISCLOSE OR USE IN PART OR IN WHOLE INFORMATION CONTAINED IN DOCUMENT.

REV	EON	REV	EON	REV	EON
0	12530	0	12530	0	12530
CPM 06/27/12	JUP 06/21/12	CPM 06/27/12	JUP 06/21/12	CPM 06/27/12	JUP 06/21/12
SCALE	SCALE	SCALE	SCALE	SCALE	SCALE
NONE	NONE	NONE	NONE	NONE	NONE

**ARIEL CORPORATION**  
 35 BLACKJACK ROAD  
 MOUNT VERNON, OHIO 43050

ASSEMBLY DWG. NO. **A-19529**  
 SHT 2 OF 2





**NOTES:**

1. SEE MANUAL FOR TORQUE VALUES (ITEM #8).
2. INSTALL PER ER-52.
3. VALVE GUARD ASSEMBLY (ITEM #2) CONSISTS OF VALVE GUARD, CENTER STUD (ITEM #3), SPIROL PIN (ITEM #7) AND DOWEL PIN (ITEM #9).

**ARIEL CORPORATION**  
 35 BLACKJACK ROAD  
 MOUNT VERNON, OHIO 43050

TITLE:	SUCTION VALVE, RX
MATERIAL:	PROCURED
DRAWN:	IG 9/24/99
CHECKED:	ED 10/1/99
SCALE:	NONE
REV	ECN
0	7799
THIS DOCUMENT AND CONTENTS THEREIN ARE PROPRIETARY TO ARIEL CORPORATION. ONLY BY WRITTEN CONSENT AND AGREED TERMS BY ARIEL CORPORATION GIVES THE RIGHT TO MANUFACTURE. BUT DOES NOT GRANT THE RIGHT TO DISCLOSE OR USE IN PART OR IN WHOLE INFORMATION CONTAINED IN DOCUMENT. DIMENSIONS ARE IN INCHES UNLESS OTHERWISE SPECIFIED. ---- DO NOT SCALE DRAWING ---- DIMENSIONING AND TOLERANCING PER ARIEL SPECIFICATION ER-17.0.1 UNLESS OTHERWISE SPECIFIED.	

REV	DESCRIPTION
?	XXXX

DWG. No: **A-9251**

8/01/12

PARTS LIST

0.3980=A  
0.6930=B  
2.4720=C  
0.0550=LFT

PART NO. B-4087-BB  
REF DRAWING A-9251

ITEM	PART NUMBER	QTY	DESCRIPTION
1	A-12991	1	SUC VLV SEAT, 52RX
2	A-12992-A	1	SUC VLV GUARD ASSY,52RX
3	A-12990	1	CNTR STUD,5/16-24,2.36 THK
4	A-11606	1	VALVE PLATE, 52RX, .157 THICK, MTX
5	A-10357	1	GUIDE RING,52RX,.279 THK
6	A-1002	3	SPRING PLATE, 52RX, .020 THICK
7	A-1314	1	SPIROL PIN,.078D X .563L
8	A-1366	1	LOCKNUT, DRAKE,5/16-24
9	A-16466	1	LOCK,STUD .098D
12	A-11437	1	VLV WASHER, 5/16,.118 THK
99	KB-4087-BB	0	KIT,VLV, 52RX ,MTX

WHEN A ZERO APPEARS IN THE QUANTITY COLUMN IT  
DOES NOT REPRESENT THE QUANTITY REQUIRED.

\*\*\* ALWAYS PROVIDE SERIAL NUMBER WHEN ORDERING SPARE PARTS. \*\*\*







# **4TH STAGE CYLINDER**



**THIS PAGE LEFT INTENTIONALLY BLANK**

8/01/12

ARIEL CORPORATION  
SALES ORDER COVER SHEET

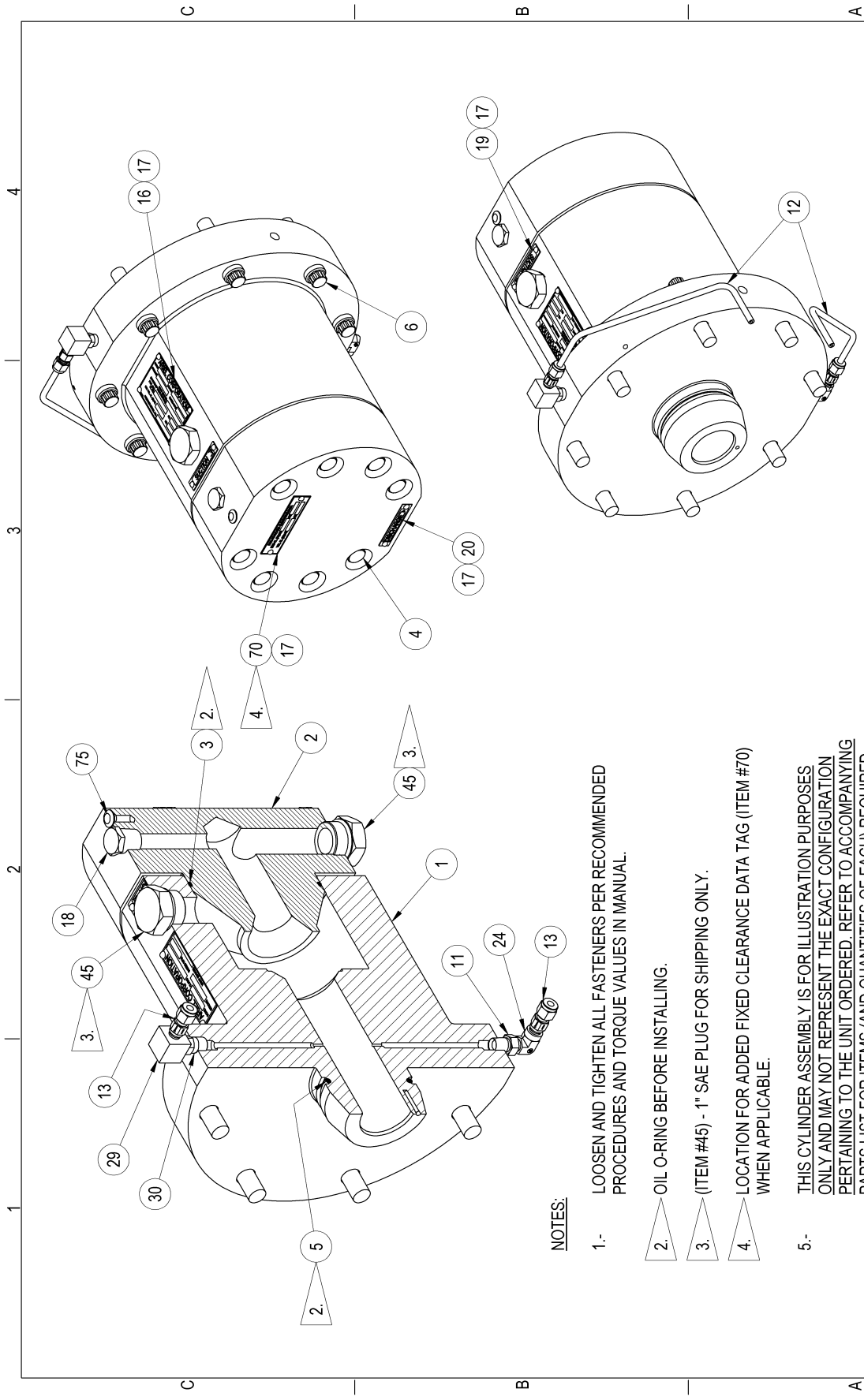
C/N: 001

RHCOVP02

SERIAL #: C-136420

PART: 1-3/4SG FS HE DESCRIPTION: 1-3/4SG-FS-HE CYLINDER CLASS

PART NUMBER	QTY	DESCRIPTION	DRAWING NO.
G-20736	1	CYLINDER ASSEMBLY, 1-5/8SG-HE, FOR 3-3/4SG-CE, 6100 MAWP	A-18941
G-1471	1	CONC VLV.ASSY(1.75JG:2R:RJ)-HE	A-6094
B-1788-E	1	CONC VLV,078/035 1-3/4,1-5/8	A-9236
G-1446	1	VLV.TOOL,1.625/1.75M:JG 2RJ-HE	B-0992



**NOTES:**

- 1.- LOOSEN AND TIGHTEN ALL FASTENERS PER RECOMMENDED PROCEDURES AND TORQUE VALUES IN MANUAL.
- 2. OIL O-RING BEFORE INSTALLING.
- 3. (ITEM #45) - 1" SAE PLUG FOR SHIPPING ONLY.
- 4. LOCATION FOR ADDED FIXED CLEARANCE DATA TAG (ITEM #70) WHEN APPLICABLE.
- 5.- THIS CYLINDER ASSEMBLY IS FOR ILLUSTRATION PURPOSES ONLY AND MAY NOT REPRESENT THE EXACT CONFIGURATION PERTAINING TO THE UNIT ORDERED. REFER TO ACCOMPANYING PARTS LIST FOR ITEMS (AND QUANTITIES OF EACH) REQUIRED FOR THIS PARTICULAR ASSEMBLY.

**ARIEL CORPORATION**  
 35 BLACKJACK ROAD  
 MOUNT VERNON, OHIO 43050



ASSEMBLY  
 DWG. NO. **A-18941**  
 SHT 1 OF 1

REV	0	17233	CPM 01/25/12	DLI 01/30/12	SCALE	NONE
REV	EON	EON	REV	EON	REV	EON

THIS DOCUMENT AND CONTENTS THEREIN ARE PROPRIETARY TO ARIEL CORPORATION. ONLY BY WRITTEN CONSENT AND AGREED TERMS BY ARIEL CORPORATION GIVES THE RIGHT TO DISCLOSE OR USE IN PART OR IN WHOLE INFORMATION CONTAINED IN DOCUMENT.

DESCRIPTION	INITIALS	DATE

8/01/12

PARTS LIST

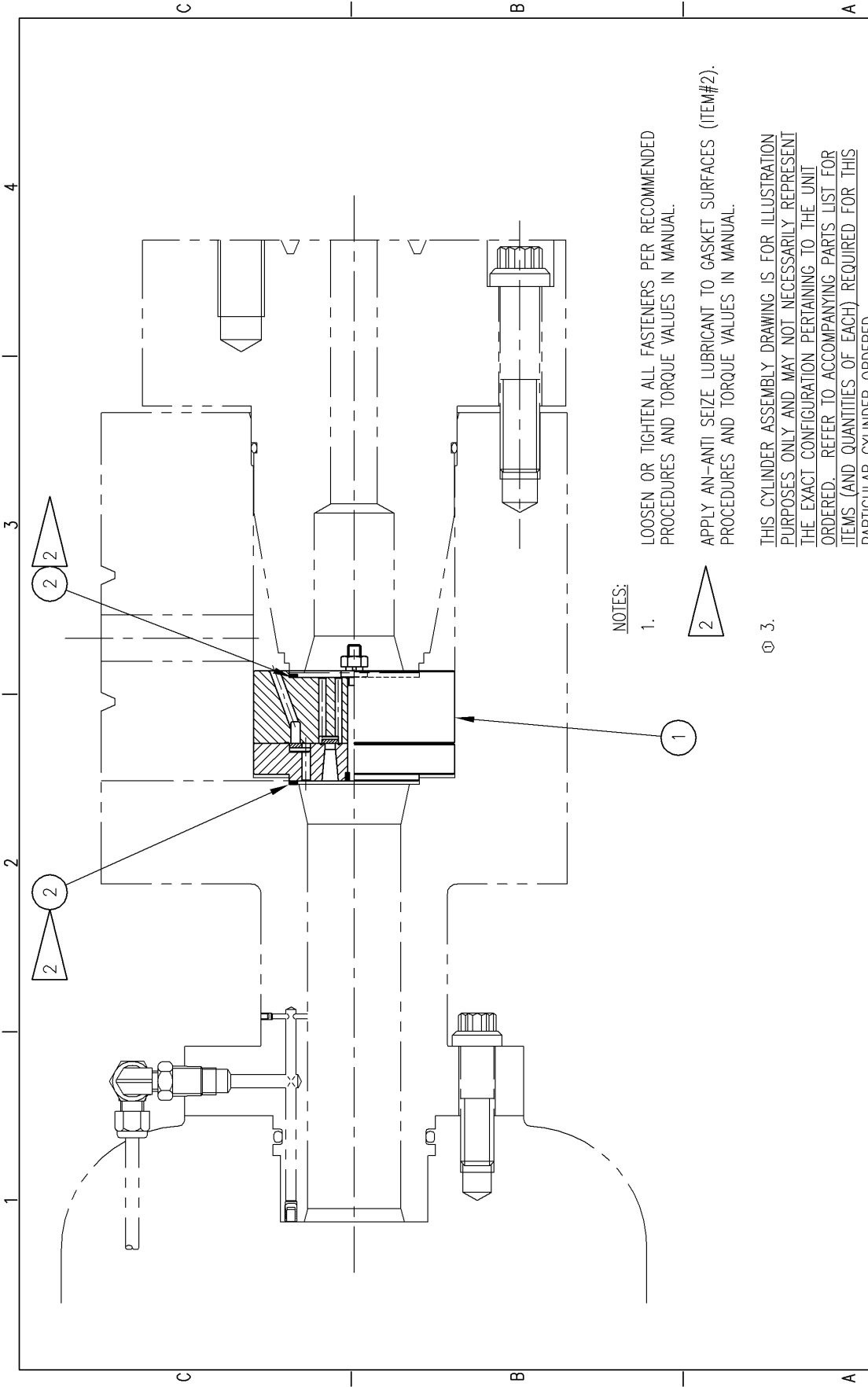
1-5/8"SG:A-HE TANDEM CYLINDER BODY AND HEAD END HEAD FOR 3-3/4SG-CE TANDEM CYLINDER.  
RDP 5545#, MAWP 6100#

PART NO. G-20736  
REF DRAWING A-18941

ITEM	PART NUMBER	QTY	DESCRIPTION
1	D-5960	0	CYLINDER, 1-5/8SG10-HE:SA10-HE, 16N, 6100 MAWP
2	C-4488	0	HEAD END HEAD, 1-3/4SG-HE CLASS
3	A-1812	1	O-RING, VT, 3.887 OD X .139, 95 DUROMETER
4	FC0120IO	8	12-POINT CAPSCREW, 3/4-10 X 3, G8
5	A-0039	1	O-RING, VT, 4.020 OD X .210, 75/85 DUROMETER
6	FC0120HO	8	12-POINT CAPSCREW, 5/8-11 X 3, G8
12	PT0201CD	83."	TUBING, 316 SS, 1/4 OD X .065 WALL
13	A-18496	1	CHECK VALVE, DOUBLE BALL, SS, 1/4 TUBE INLET X 1/8 NPT OUTLET,
16	A-0465	1	DATA PLATE, CYLINDER SPECIFICATION, 3-1/2 X 2-1/4
17	FR0571CC	8	DRIVE SCREW, TYPE U, SS, #6 X 1/4
18	PP0810GB	1	PIPE PLUG, HEX HEAD, 1/2 NPT, STL
19	A-0640-A	1	INFORMATION PLATE, SUCTION
20	A-0640-B	1	INFORMATION PLATE, DISCHARGE
29	A-17774	1	OIL TRAP, BODY, SS, 1/8 NPT
30	A-17776	1	OIL TRAP, STEM, SS, 1/4 NPT
45	PP0860JB	2	PLUG, STL, SAE-16
100	HD-6102	1	CYLINDER HYDROTEST SET, 1-5/8SG-HE:SA-HE, FOR 3-3/4SG-CE:SA-CE, 6100 MAWP

WHEN A ZERO APPEARS IN THE QUANTITY COLUMN IT DOES NOT REPRESENT THE QUANTITY REQUIRED.

\*\*\* ALWAYS PROVIDE SERIAL NUMBER WHEN ORDERING SPARE PARTS. \*\*\*



NOTES:

1. LOOSEN OR TIGHTEN ALL FASTENERS PER RECOMMENDED PROCEDURES AND TORQUE VALUES IN MANUAL.
2. APPLY AN-ANTI SEIZE LUBRICANT TO GASKET SURFACES (ITEM#2). PROCEDURES AND TORQUE VALUES IN MANUAL.
3. THIS CYLINDER ASSEMBLY DRAWING IS FOR ILLUSTRATION PURPOSES ONLY AND MAY NOT NECESSARILY REPRESENT THE EXACT CONFIGURATION PERTAINING TO THE UNIT ORDERED. REFER TO ACCOMPANYING PARTS LIST FOR ITEMS (AND QUANTITIES OF EACH) REQUIRED FOR THIS PARTICULAR CYLINDER ORDERED.

 <b>ARIEL CORPORATION</b> 35 BLACKJACK ROAD MOUNT VERNON, OHIO 43050		APPROVER:	NONE
		CHECKER:	NONE
1	11493	DRAWN:	CAH 12/26/95
0	6000	CHECKED:	
REV	ECN	SCALE:	

THIS DOCUMENT AND CONTENTS THEREIN ARE PROPRIETARY TO ARIEL CORPORATION. ONLY BY WRITTEN CONSENT AND AGREED TERMS BY ARIEL CORPORATION WILL THE RIGHT TO DISCLOSE OR USE IN PART OR IN WHOLE INFORMATION CONTAINED IN DOCUMENT.

1	ADD NOTE #3. UPDATED TO CURRENT STANDARDS.	REV	DESCRIPTION
		INIT/DATE	
		AW	06/07/2003

8/01/12

PARTS LIST

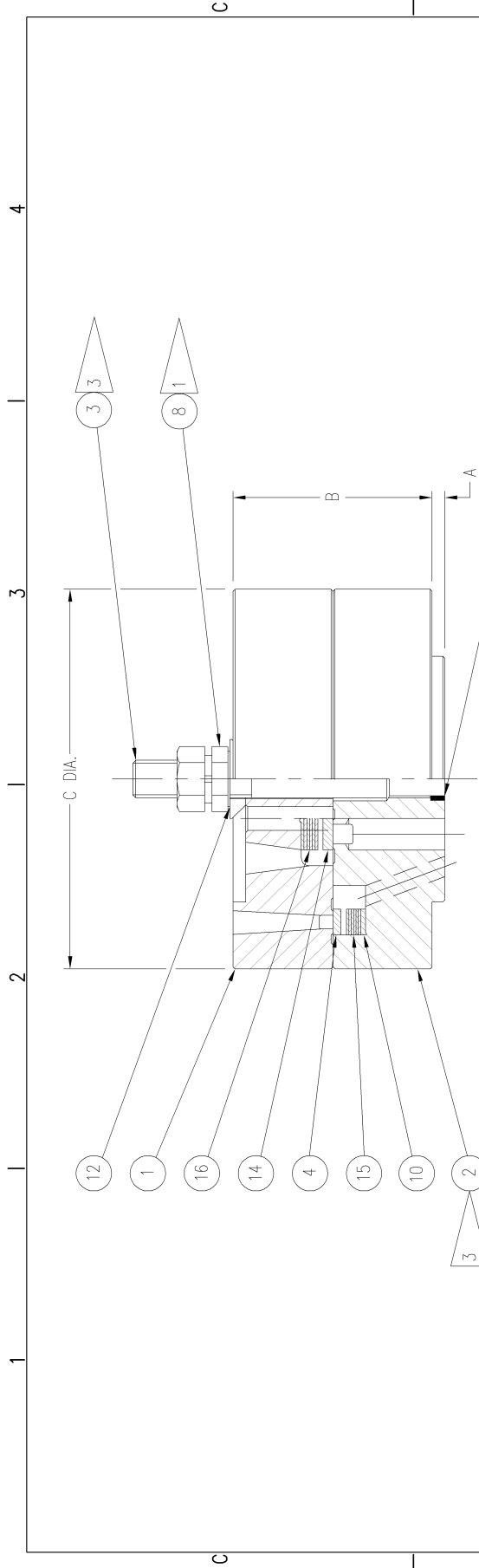
CONCENTRIC VALVE, RETAINER, CAP  
1-3/4JG-HE:2R-HE:2RJ-HE CLASS  
STEERLE CYLINDER

PART NO. G-1471  
REF DRAWING A-6094

ITEM	PART NUMBER	QTY	DESCRIPTION
1	CONCENTRIC VLV	0	FOR PART NO. SEE COVER SHEET
2	A-12084	2	STEEL GASKET, 02.438 OD X 02.125 ID X .060, VALVE

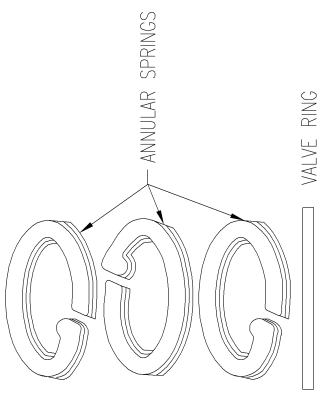
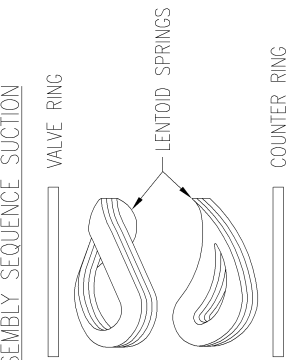
WHEN A ZERO APPEARS IN THE QUANTITY COLUMN IT  
DOES NOT REPRESENT THE QUANTITY REQUIRED.

\*\*\* ALWAYS PROVIDE SERIAL NUMBER WHEN ORDERING SPARE PARTS. \*\*\*



① ASSEMBLY SEQUENCE DISCHARGE

① ASSEMBLY SEQUENCE SUCTION



NOTES:

1. SEE MANUAL FOR TORQUE VALUES (ITEM #8).
2. INSTALL PER ER-52.
3. LOWER PART ASSEMBLY (ITEM #2) CONSISTS OF LOWER PART, CENTER STUD (ITEM #3) AND SPIROL PIN (ITEM #7).

**ARIEL CORPORATION**  
 35 BLACKJACK ROAD  
 MOUNT VERNON, OHIO 43050

TITLE: <b>CONCENTRIC VALVE</b>		MATERIAL: <b>PROCURER</b>	
REV	ECN	DATE	BY
1	13965	IG 09/23/99	IG
0	7799	ED 10/04/99	ED
SCALE: <b>NONE</b>		DWG. No.: <b>A-9236</b>	
DESCRIPTION		INIT/DATE	MLB
① UPDATED DRAWING TO CURRENT STANDARDS. ADDED VIEWS SHOWING ASSEMBLY SEQUENCE FOR BOTH SUCTION/DISCHARGE SHOWING ORIENTATION OF LENTOID AND ANNULAR SPRINGS.		09/29/06	
THIS DOCUMENT AND CONTENTS THEREIN ARE PROPRIETARY TO ARIEL CORPORATION. ONLY BY WRITTEN CONSENT AND AGREED TERMS BY ARIEL CORPORATION GIVES THE RIGHT TO MANUFACTURE, BUT DOES NOT GRANT THE RIGHT TO DISCLOSE OR USE IN PART OR IN WHOLE INFORMATION CONTAINED IN DOCUMENT. DIMENSIONS ARE IN INCHES UNLESS OTHERWISE SPECIFIED. ----- DO NOT SCALE DRAWING -----			

8/01/12

PARTS LIST

0.1260=A  
1.9770=B  
3.7760=C  
0.0470=LFT

PART NO. B-1788-E  
REF DRAWING A-9236

ITEM	PART NUMBER	QTY	DESCRIPTION
1	A-4876	1	UPPER PART CONC VLV
2	A-4877-A	1	LOWER PART ASSY, CONCENTRIC VLV
3	A-1842	1	CNTR STUD, 3/8-24 X 3.15
4	A-1844	1	VALVE RING, 78CD
8	A-1367	1	LOCKNUT, DRAKE 3/8-24
9	A-16466	1	LOCK, STUD .098D
10	A-1848	1	COUNTER RING, 78C1, CONCENTRIC VALVE
12	A-1847	1	VLV WASHER, 3/8
14	A-1843	1	VALVE RING, 35CD10
15	A-1845	6	LENTOID SPRING, CONCENTRIC VALVE
16	A-1846	6	ANNULAR SPRING, 35CD1, CONCENTRIC VALVE

WHEN A ZERO APPEARS IN THE QUANTITY COLUMN IT  
DOES NOT REPRESENT THE QUANTITY REQUIRED.

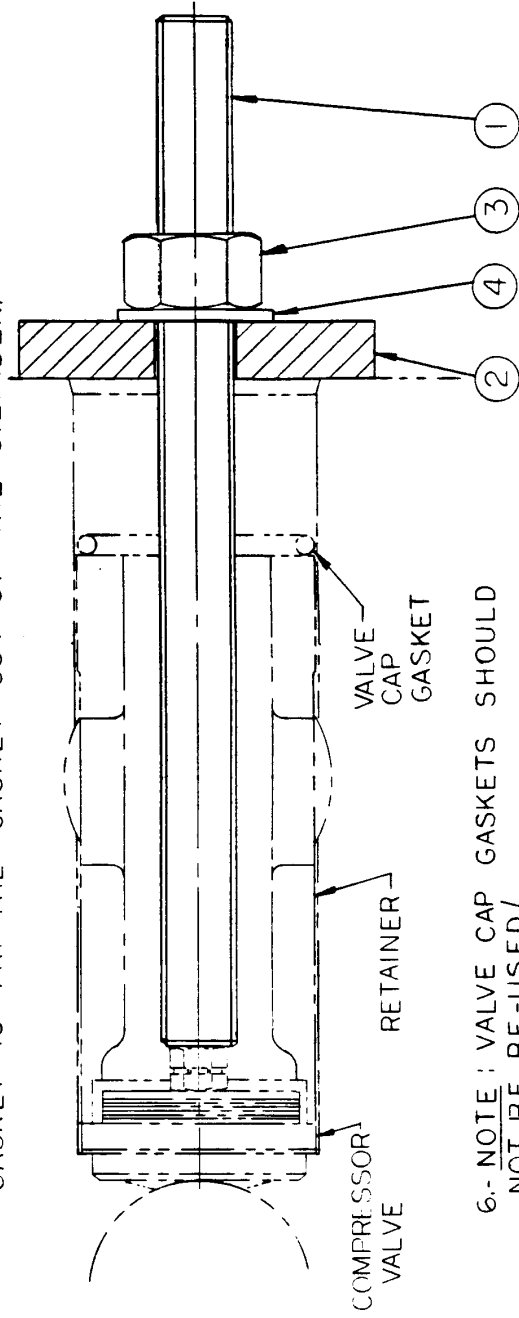
\*\*\* ALWAYS PROVIDE SERIAL NUMBER WHEN ORDERING SPARE PARTS. \*\*\*



G-1446  
G-1809

TO REMOVE A COMPRESSOR VALVE :

- 1.- AFTER DEPRESSURIZING THE CYLINDER AND REMOVING THE VALVE CAP ; ATTACH THE VALVE PULLER STUD, ITEM\*1 TO THE VALVE STUD.
- 2.- SLIDE THE VALVE PULLER PLATE, ITEM\*2 OVER THE END OF THE PULLER STUD SO THAT IT RESTS ON THE CYLINDER BODY.
- 3.- SLIDE THE WASHER, ITEM\*4 OVER THE STUD AND THREAD THE NUT, ITEM\*3 ONTO THE STUD.
- 4.- TIGHTEN THE NUT, THIS WILL PULL THE VALVE, RETAINER AND VALVE CAP GASKET OUT OF THE POCKET.
- 5.- THE ASSEMBLY ONLY NEEDS TO BE PULLED FAR ENOUGH OUT OF THE POCKET SO THERE IS ROOM BETWEEN THE TOP OF THE RETAINER AND THE VALVE CAP GASKET TO PRY THE GASKET OUT OF THE CYLINDER.



6.- NOTE : VALVE CAP GASKETS SHOULD NOT BE RE-USED!

6/2/00  
1

ASTEL CORPORATION  
MT. VERNON, OHIO  
ASSY.  
DRWG. NO.: B-992

8/01/12

PARTS LIST

VALVE REMOVAL TOOL  
1-3/4"M:JG-HE, 2"R-HE:RJ-HE

PART NO. G-1446  
REF DRAWING B-0992

ITEM	PART NUMBER	QTY	DESCRIPTION
1	A-1759	1	A/T STUD,VLV PULLER,1-3/4M
2	A-1760	1	PLT,VLV PULLER,1-3/4M
3	FN0451HD	1	HEX NUT,H/W,2H,5/8-11
4	FW0500HA	1	WASHER, 5/8 SAE

WHEN A ZERO APPEARS IN THE QUANTITY COLUMN IT  
DOES NOT REPRESENT THE QUANTITY REQUIRED.

\*\*\* ALWAYS PROVIDE SERIAL NUMBER WHEN ORDERING SPARE PARTS. \*\*\*

# **VENDOR'S LITERATURE**

**HOERBIGER VALVES**

**PROFLO JR NO-FLOW SWITCH**

**GORMAN-RUFF PUMP**

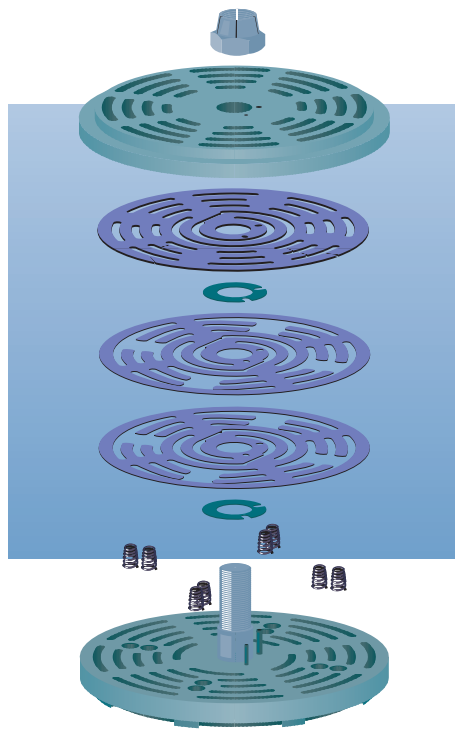
**COOK ROD & RINGS**

**THIS PAGE LEFT INTENTIONALLY BLANK**

COMPRESSION  
TECHNOLOGY  
GROUP

Service Guide

## SERVICE GUIDE FOR MAINTENANCE OF HOERBIGER VALVES



**HOERBIGER**

# SERVICE GUIDE FOR MAINTENANCE OF HOERBIGER-VALVES

**Modern compressors equipped with HOERBIGER-Valves require a minimum of maintenance. The performance and the reliability of such compressors depend, however, to a large degree on the care applied to these few maintenance operations.**

AT WHAT INTERVALS HAS MAINTENANCE OF VALVES TO BE CARRIED OUT?

We cannot give any general guide lines as valve life is influenced by many parameters. Maintenance frequency will depend for example on the type of compressor (e.g. Process machine or garage compressor), whether the compressor is running on continuous duty or intermittent duty, on the compressor speed and pressures, the compression ratio, also the type of gas (corrosive or non-corrosive gas, clean gas with or without carry-over of foreign material, moisture content). The compressor manufacturer will have established guide lines both for the running in period and subsequent operation, which will have to be followed. Experience proves that after the initial running - in period the maintenance intervals can be extended considerably.

THEY COVER THE FOLLOWING PROCEDURES

- 1 Remove valve from compressor**
- 2 Dismantle the valve**
- 3 Clean all parts**
- 4 Check the condition of all components**  
especially for wear, damage to the seat face, the plates, and for setting of the springs.
- 5 Repair or replace worn parts**  
Repair all parts which can be remachined without impairing the strength. Replace all parts which are worn or show any cracks.
- 6 Reassemble the valve**  
following the instructions on our drawing or assembly sheet.

RECOMMENDATIONS AND WARNINGS

**1 Recommendations and warnings are to be followed according to the compressor manufacturer.**

**In case our recommendations and warnings deviate from those of the compressor manufacturer, the ones of the compressor manufacturer take precedence.**

ASSEMBLY DEVICE

The HOERBIGER Assembly Device allows the valve to be held correctly without danger of damage. Adjustable location pins secure the valve against rotation. These pins locate in the slots of the seat or guard respectively without causing damage. The best way to tighten the nut is with a torque wrench. HOERBIGER Assembly Devices can be used for all valve types. The standard clamps will hold heights "H" (fig. 12) up to 78 mm. The base plate can be screwed on to any work bench or held in a suitable holding device.

**3 sizes are available:**

Size	max. O. D. of valve mm	L mm	B mm
1	20-100	260	120
2	20-250	420	200
3	20-430	590	350

fig. 1



## 1 Remove valve from compressor

**2** Before valves are removed from the compressor, all pressure has to be released from the cylinders and piping. If combustible or poisonous gases are present, cylinder and piping have to be vented. Take necessary measures to prevent start up of the compressor. If the compressor valve is stuck in the cylinder, try to use valve puller device. If valve is to be jarred free by striking, use a wood block or soft metal bar to avoid damage. Never use a steel hammer to strike the valve directly.

## 2 Dismantle the valve

After sufficient cleaning of the center bolt and loosening of the locking device of the unit (either by removing of the cotter pin in case of a castle nut, or by pressing down the ends of the locking washer, if equipped with same), the valve should be held by means of a simple holding device shown in fig. 3 and 4. The holding pins keep the valve from rotating. It is better to use our Standard Assembly fixture shown in fig. 1 and 2 where the valve parts are clamped down effectively.



fig. 2



fig. 3



fig. 4

**3** In order to prevent the locating pins in the valve from shearing off, it is advisable to hold the suction seat and delivery guard respectively, while loosening or tightening the nut especially in the case of valves with open guard (fig. 5).



fig. 5

## 4 How it should not be done!

Never should a valve be directly tightened in a vice, neither as shown in fig. 6 on the shoulder, nor as shown in fig. 7. Do not hammer on the wrench when loosening or tightening the nut (fig. 8 and 9).

fig. 6



fig. 7



fig. 8



fig. 9



### 3 Clean all parts

with a cleansing fluid using a soft brush, taking particular care to free the ports of the seat and the guard from all foreign matter to ensure full seat area in operation. Never use wire brushes or tools with sharp edges to clean the seats and plates.

**5** All precautionary measures stipulated by the Occupational Safety and Health Act of 1970 (OSHA) or local safety instructions must be adhered to when handling solvents.

Caution: all excess solvent solutions used in the cleaning of compressor valves and/or pockets should be removed prior to start-up since their presence may cause an explosion hazard.

### 4 Check the condition of all components

**6** Use only genuine HOERBIGER replacement parts.

### 5 Repair or replace worn parts

#### Valve plates

When a valve plate, or damper plate shows signs of wear, it is imperative to replace these parts, even if no breakage has occurred.

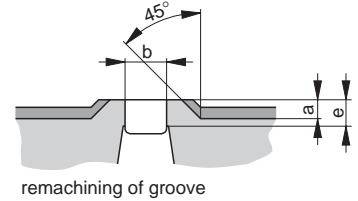
**7** Valve plates and rings when worn should be replaced, not reground or inverted.

**8** When a spring in a valve shows signs of deterioration, not only that particular spring but all springs must be replaced in this valve. In the case of conical springs care should be taken that they are inserted into the spring well with the large diameter resting at the bottom of the spring well (fig. 10).

#### Seats

For highest efficiency of the valve it is important that the seat face is flat and free of any traces of wear, thus preventing valve leakage. If any damage of the seat face appears, it is necessary to remachine and lap the seating areas. Locating pins, if fitted, have to be removed first of all. Generally remachining is done by concentric grinding and lapping. If the seat face shows only slight defects, lapping alone may prove satisfactory. Also remachining on a center lathe with very low feed may be considered, particular attention being paid to the seat face being machined. Burrs are best removed with emery paper (fig. 11.1 and 11.2)

**9** When a valve seat surface is remachined, new valve plates or rings must be used to assure proper seal.

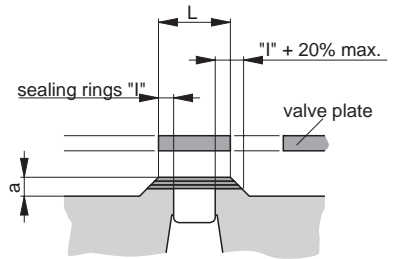


remachining of groove

fig. 11.1

#### How often may a valve seat be remachined?

Under no circumstances must the bottom of the turned slots be machined to increase the depth, as this would impair the strength of the seat. The following may serve as a rough guide for remachining of seats. The material thickness „e“ (fig. 11.1) under the seating ledge should not be reduced to less than 60% of the slot width „b“ an



remachining of seat-face

fig. 11.2

exception to the above are the steel seats of valve Types 52 R and 42 R, for which dimension „e“ should be limited to 1.2 mm minimum. Every grinding or lapping of the seat face increases the width of the ring surface marked „I“ in fig. 11.2. In order to keep the dimension constant the grooves have to be remachined. The maximum increase on width which can be tolerated is 20%.

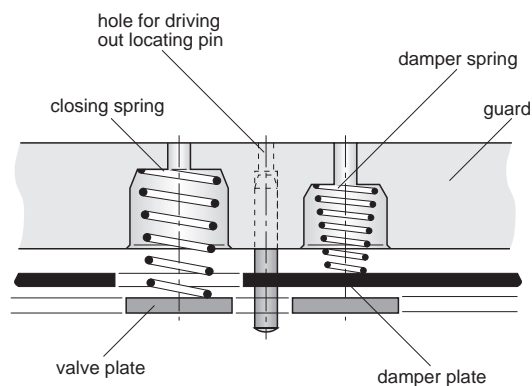


fig. 10



**10** Do not remachine valve seats below the specified minimum dimension, otherwise there is danger of breakage.

**11** Remachining has to be extended over the entire seat-face, including the center where lift washers or guide rings are located, in order to avoid any change of the valve lift.

Center bolts are secured into seats (or guards) with a dowel pin (Version A) or a bolt lock using a small ball (Version B). To remove the centre bolt, drill out the (soft) dowel pin or ball and unscrew the bolt. Upon re-assembly drill a new hole in the thread area of the

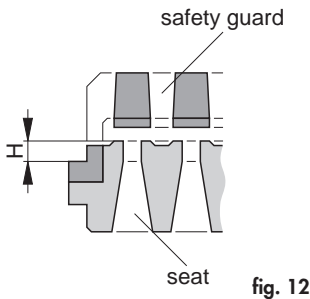


fig. 12

bolt and the seat or guard, respectively, and insert a new pin or ball to secure the bolt from coming loose.

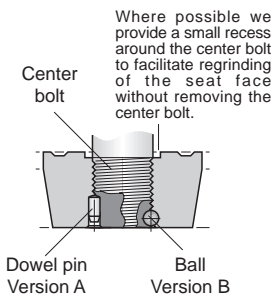


fig. 13

The dowel pin or ball, after it is inserted, has to be peened (slightly hammered in) to prevent it from falling out (fig. 13).

If so-called safety guards (Standard design fig.16) are centered on the seat, care must be taken to maintain dimension „H“ (fig. 16). This means any centering step on the seat, must be remachined to the same extent as the seat face.

After remachining of the seat the locating pins have to be refitted (fig. 15).

**12** If the valve plate and guide plate are riveted together, the groove in the valve seat under the rivets has to be remachined after every grinding to prevent the rivet heads from hitting the seat. Remachine until the rivet has ample clearance (fig. 14).

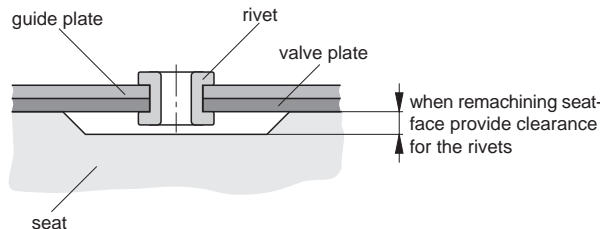


fig. 14

**Locating Pins**

Locating pins, which have been removed from the seat before the remachining, have to be refitted, taking care that the free length is the same as before (fig. 15). If necessary, the pin holes have to be drilled deeper in order to ensure that the maximum free length is not exceeded. If the pin in the seat or the hole is damaged redrill the locating pin holes displaced by 180°.

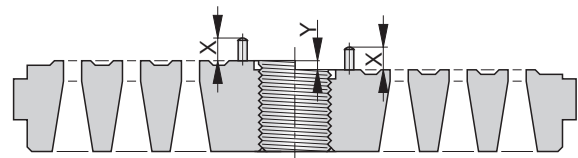


fig. 15  
X... free length before and after remachining  
Y... height reduction by remachining

The diameter of the new hole has to provide a press fit (dia. of drill. 0.1 mm less than dia. of locating pin). Make sure that the locating pins are at right angles to the seat face. When re-assembling the valve align the seat with the guard. In this position the nut can be tightened. Never tighten the nut without positioning the seat and guard properly. Any damage of the locating pins can impair the proper functioning of the valve.

Certain valves have no hole in their seat to accept the free end of the locating pin. Such valves are provided with marking holes on the periphery of seat and guard or visually by aligning the webs of the seat and guard, which must be lined up before the valve nut is tightened down (see fig. 16).

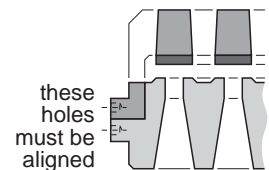


fig. 16

## 6 Reassemble the valve

Take special care in assembling the valve and follow procedures shown on our drawings. We are glad to give any further advice should problems arise. If valves are equipped with lock washers or locking plates, they have to be replaced after every dismantling. For more convenient assembly of the valve it is a good practice to grease the spring pockets, in order to hold the springs in place. **This does not apply for valves of oxygen compressors.** You will do a better job if you use a torque wrench for tightening the selflocking nut. (Follow the torque table given in this leaflet). When tightening the nut hold the suction seat, or the discharge guard, especially in case of valves with open guards (fig. 5) both parts should not move relative to each other. This could damage the locating pins in the valve and result in valve failure. Certain valves are provided with marking holes on the periphery of seat and guard which must be lined up before the valve nut is tightened down (fig. 16).

**13** Never use oil or grease for valves used on oxygen-compressors!

**14** Tightening torque of center bolt nut has to be maintained as specified. Bolt and nut threads must be clean, free of burrs and well lubricated. **CAUTION:** With Oxygen Compressors. Valves have to be completely free of oil and grease. Inspect valve again before installation. Failure to do so may result in an **EXPLOSION!** Never use self locking nuts on austenitic stainless steel material.

The torques listed in the table are for greased nuts and bolts. The data is only valid with a Genuine Centre Bolt. Self locking nuts should always be lubricated before tightening.

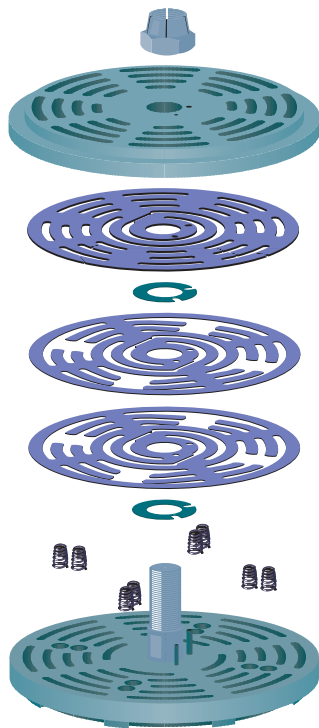


fig. 17

**15** If suction valves are equipped with unloaders, the clearance between the valve plate and unloader finger as well as the clearance between unloader and actuator push rod has to be checked.

**16** Valve plates have to be checked for free movement.

**17** Before assembling the valve into the cylinder also clean the valve pocket and the cages.

**18** When re-installing valves, do not interchange suction and discharge valves - **DANGER OF EXPLOSION!**

**19** Do not install discharge valves upside down - **DANGER OF EXPLOSION!**

**20** Valves must always be placed in the cylinder with the center bolt and nut **AWAY** from the cylinder bore.

**21** Set screws or cover stud nuts holding the valve in place have to be tightened to the specified torque values, otherwise there is danger of valve seat breakage.

**22** After all of the valves are installed, bar over the compressor at least one complete revolution to be certain there is no interference with moving parts.



fig. 18

Table of torque.  
(valid for castle nuts, slotted nuts  
and self locking nuts).

# PRACTICAL LEAKAGE TESTING OF COMPRESSOR VALVES

Compressor valves should be flowefficient and durable in service. Leakage is one criteria that impacts on both of the above. Excessive leakage causes back-flow of gas when the valve is closed, raises the temperature of the gas and reduces efficiency. Elevated temperatures also adversely affect valve life.

For this reason, HOERBIGER's quality assurance program dictates that all valves are subjected to a leakage test. This policy covers newly made valves in our production plants and repaired valves in all our service centers. Different geometry valves and sealing elements made from steel or non-metallic material all undergo such rigorous testing.

Test methods may vary but preference is given to those procedures that simulate the conditions as they exist in a cylinder.

## VALVE TESTING METHODS

There are 3 customary leakage test procedures, and HOERBIGER recommends 2 of the testing methods.

### Flow Meter Testing

The leakage is determined by subjecting the closed valve to a "set" air pressure of e.g. 5 bar (70 PSI) and measuring the leakage through the valve by means of a flow meter (fig. 19).

Since small contaminants at times can be caught between the valve plate and seat lands,

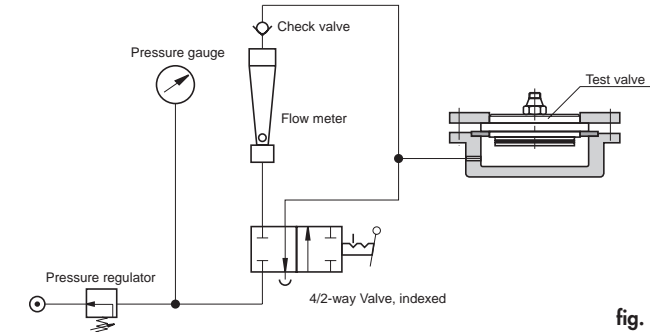


fig. 19

it is common practice to "tap" the valve plate in several areas repeatedly. This will briefly lift the plate off the seat lands and the escaping air will blow out any small particles that might be trapped between the sealing surfaces and cause excessive leakage.

This should be done with an appropriate tool (flat or soft-tipped) so no damage is done to the valve plate or sealing element. Particular care is called for when non-metallic plates are used so no damage is done to these components.

The time for the pressure drop to occur and parameter for acceptable leakage are dependent on the valve size, volume of the vessel and the selected pressures of p1 and p2.

The prior "tapping" of the valve to blow out any impurities should be standard practice in this test procedure as well.

### Liquid Testing

Test procedures as discussed under 2.1 and 2.2 are compatible and represent conditions as they prevail in the compressor cylinder. The sealing element is "pressure loaded" much like it is in its operating environment when installed in a cylinder (the suction valve is kept closed by the cylinder pressure while the discharge valve is under the influence of the line pressure).

### Measuring Pressure Drop

In this test method, leakage is measured in pressure drop over time, using a fixed volume "V" (air supply is shut off) and measuring the time it takes for the pressure to drop from p1 to p2 (fig. 20).

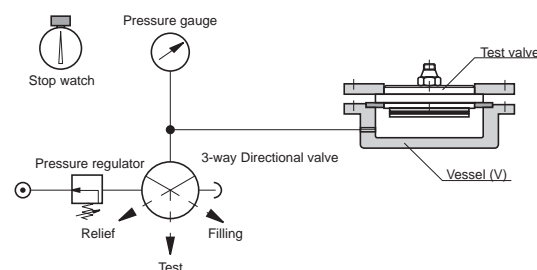


fig. 20

Thread size METRIC mm	Carbon Steel Min. tensile strength 800 N/mm <sup>2</sup>		Austenitic Stainless***) (En 58) Min. tensile strength 550 N/mm <sup>2</sup>	
	Martensitic Stainless Steel*) (En56) Min. tensile strength 750 N/mm <sup>2</sup>			
	Torque in Nm		Torque in Nm	
	Minimal	Maximal	Minimal	Maximal
4	1,2	1,5	1,0	1,2
5	2,4	2,9	1,8	1,2
6	4,1	5,0	3,2	3,8
8	10,0	12,0	7,5	9,0
10	20,0	24,5	15,5	18,5
12	36,0	44,0	28,0	33,0
14	57,0	69,0	43,0	52,0
16	90,0	110,0	70,0	85,0
20	178,0	215,0	135,0	160,0
22	245,0	295,0	185,0	220,0
24	305,0	370,0	230,0	280,0
27	330,0	400,0	330,0	400,0
30	450,0	540,0	450,0	540,0

\*) Martensitic stainless steel (magnetic) is used with slightly corrosive gases  
 \*\*) Austenitic stainless steel (non magnetic) is used with highly corrosive gases

## testing

Frequently, field people do not have access to leakage testers and resort to a simple "liquid testing" of the valve.

Filling the seat ports of a valve with a fluid and observing the leakage rate of the fluid through the valve is a common practice. Kerosene, Varsol and other light viscosity fluids (even water) are employed in such crude leakage tests.

Although the procedure is widely used, it is not without controversy as to the viability of its results. Contrary to the previously described methods of air pressure testing, the liquid test does not simulate conditions as found in the cylinder. The fluid pre-loads the sealing element towards its opening lift, and test results can be distorted, especially if valves use non-metallic sealing elements and if the pre-load of the springs used in the valve is very light.

Certain valves, due to their design, cannot be tested at all with the fluid method, and others will create the appearance of "leakers" when their sealing characteristic under air pressure is perfectly acceptable. This test method, therefore, is controversial and should be avoided whenever possible. The cleaning process described in air testing cannot be applied in liquid tests, and any impurities in the sealing area will show as excessive leakage.

Frequently, such liquid tests lead to unnecessary labor and repair of the valve which would possibly be termed fine under air tests.

It is recognized that proper testing of valves with air pressure is not always possible, but it remains the superior procedure and should be adopted wherever possible.



**Our experts  
are available  
at any time -  
worldwide**



# HOERBIGER

**THIS PAGE LEFT INTENTIONALLY BLANK**

# Proflo Jr. No-Flow Switch

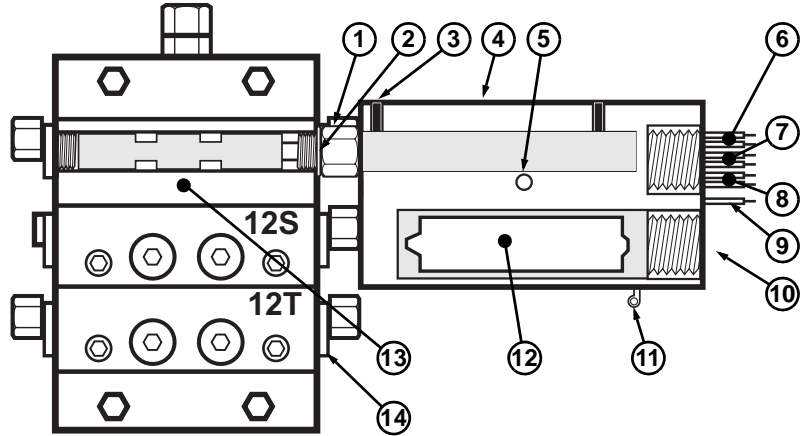
## Installation

**CAUTION: Explosion hazard - no user serviceable parts. Do not disconnect wiring while circuit is live. Complete all field wiring in accordance with local codes pertaining to potentially explosive atmospheres. Do not open battery compartment in areas known to contain explosive gases.**

1. Loosen the two Allen head set screws on top of Proflo Jr. case and remove magnet housing. Do not remove magnet, spring, and spacer from magnet housing.
2. Remove piston end plug from desired divider valve. The Proflo Jr. installs on either side of any divider valve, but requires the correct magnet housing for each divider valve manufacturer (Trabon, Dropsa, etc.).

**NOTE: Do not install the Proflo Jr. on any divider valves with cycle indicator pins.**

3. Verify O-ring is in place on magnet housing. Thread magnet housing into end of divider valve. Torque magnet housing to 15 foot-pounds max.
4. Slide Proflo Jr. all the way onto magnet housing. Torque Allen head set screws to 15 inch-pounds max. **DO NOT** over tighten set screws.
5. The LED on the Proflo Jr. indicates one complete cycle of the divider valve system. Verify correct operation by pumping oil through the divider valve assembly. The force feed lubricator data plate on the lubricator box indicates either normal and break-in cycle times at maximum rated speed, or normal cycle time for applied speed. Use break-in cycle times only for the first 200 hours of operation before changing to the normal cycle time. If unable to determine cycle time, contact the Ariel Response Center.
6. For Lincoln divider valves it may be necessary to adjust the Proflo Jr. by sliding it back about 1/8" on the magnet housing until the LED flashes. All conduit and connections should be appropriate for area classification. Use flexible conduit to ease installation. Support conduit and fittings to



- |                             |                          |                   |
|-----------------------------|--------------------------|-------------------|
| 1. Magnet Housing           | 5. LED                   | 10. Battery Plug  |
| 2. O-Ring                   | 6. Red Wire Leads (2)    | 11. Grounding Lug |
| 3. Allen Head Set Screw (2) | 7. Orange Wire Leads (2) | 12. Battery       |
| 4. Proflo Jr. Case          | 8. Yellow Wire Leads (2) | 13. Divider Valve |
|                             | 9. Green Wire Lead (1)   | 14. End Plug      |

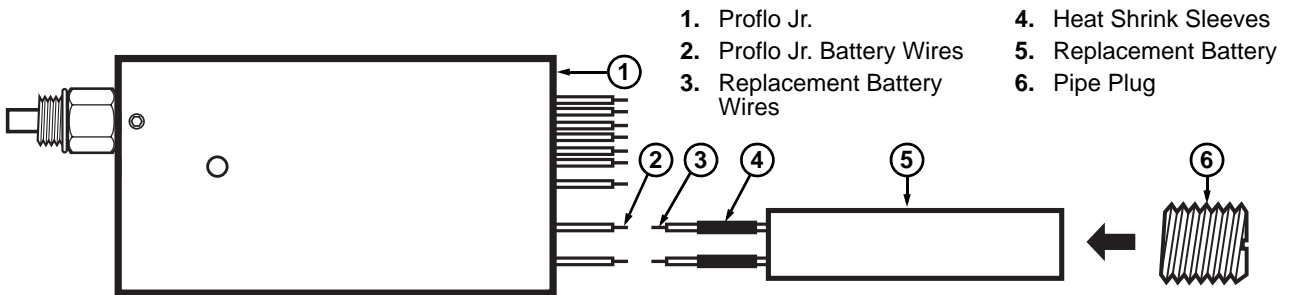
**FIGURE 1-1 Proflo Jr. Installation**

REV	DESCRIPTION	REV	EC	DATE	REV	EC	DATE
0							
		0	016387	2-24-10			

minimize vibration.

- After Proflo Jr. installation or performance of any maintenance on the lube system, compressor cylinders, or packing, **pre-lube the complete system with a purge gun to purge air from the divider valves and all components BEFORE COMPRESSOR START-UP.**

## Proflo Jr. Battery Replacement



**FIGURE 1-2 Proflo Jr. Battery Replacement**

If battery voltage drops below normal operating levels, the Proflo Jr. shuts down and the compressor cannot be re-started until the battery is replaced. The Battery Replacement Kit contains one battery assembly with heat shrink.

**CAUTION: Do not open the Proflo Jr. in an explosive gas atmosphere.**

- Remove the large silver pipe plug. A large flat bit is required to break the pipe plug free.
- Plug removal exposes the old battery. Grab the heatshrink on the battery with needle nose pliers and pull the battery out of the housing. Untwist the red and black Proflo Jr. wires.
- Cut the Proflo Jr. wires free from the old battery as close to the battery as possible.
- Remove about 3/8 in. of insulation from the ends of the Proflo Jr. wires.
- Remove about 3/8 in. of insulation from the ends of the replacement battery wires.
- Slide heat shrink sleeves over the replacement battery wires.
- Solder the bare ends of the replacement battery wires to the bare ends of the Proflo Jr. wires. Match red to red and black to black.
- Slide heat shrink sleeves over the soldered wire ends and shrink using a heat gun.
- Twist battery wires 4 – 5 turns and slide the battery into the Proflo Jr. compartment.
- Thread the pipe plug back into the Proflo Jr. until the plug top is flush with the case.

## Proflo Wire Identification and Electronic Indication Instructions

**2 Red Wires: Normaly Open (N/O).** Connect one to the control panel for no-flow shutdown and the other to ground. Electrical rating: 300 VDC/120 VAC @ 500 mA max.

**2 Orange Wires: Normally Closed (N/C).** Connect both to the control panel for closed loop operation. Electrical rating: 300 VDC/120 VAC @ 500 mA max.

**2 Yellow Wires: Switch closure output.** Use these wires to send a switch closure output with each divider valve cycle to a PLC, Scada system, digital counter, or digital control panel. Electrical rating: 30 VDC @ 200 mA max.



**1 Green Wire and 1 External Lug: Ground.** Securely ground the green wire or lug to an "earth ground" on the compressor frame or in the control panel. Do not ground to the electrical conduit. Improper grounding can result in unreliable monitor operation.

**CAUTION: N/O and N/C outputs are not isolated; use N/O or N/C alarm outputs, not both. Insulate all wires from contact with each other or anything else when not in use.**

## **Electronics & Compressor Protection when Arc Welding**

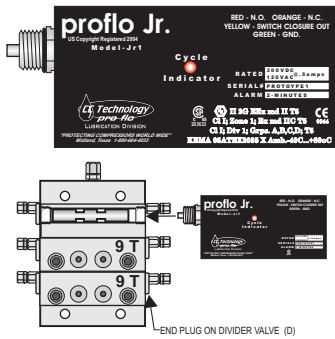
Any arc welding on the skid and/or associated equipment and piping can permanently damage solid-state electronic equipment. Welding can cause immediate failure or reduce electronic equipment life and void the warranty.

Protect electronic equipment prior to any arc welding (including repair welding) as follows: Disconnect all electrical connections including ground, and remove batteries. Or completely remove the electronic equipment from the compressor.

It is good practice to attach the welding ground clamp as close as possible to the area where the welding will occur and to use the lowest practical welder output setting. Welding must not cause a current flow across any compressor bearing surface, including but not limited to crankshaft and crosshead bearing surfaces.



**THIS PAGE LEFT INTENTIONALLY BLANK**



**2 RED WIRES: Normally Open N/O.** Connect one to control panel for no-flow shutdown, one to ground. 300 VDC/120VAC @ .5 A max.

**2 ORANGE WIRES: Normally Closed N/C.** Connect to control panel for closed loop operation. 300 VDC/120VAC @ .5 A max.

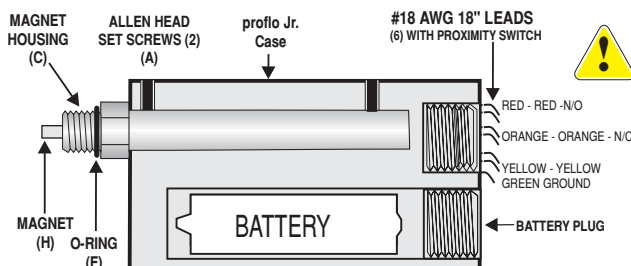
**2 YELLOW WIRES: Switch closure output.** The two (2) yellow wires are used to send a switch closure output with each divider block cycle to a PLC, Scada System, Digital Counter or Digital Control Panel.

**1 GREEN WIRE: Ground**

**Caution: N/O & N/C OUPUTS ARE NOT ISOLATED, USE NORMALLY OPEN OR NORMALLY CLOSED ALARM OUTPUTS, NOT BOTH. INSULATE ALL WIRES from contact with each other or anything else when not in use.**

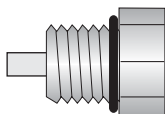
### INSTALLATION PROCEDURE FOR proflo Jr. MODEL Jr1

1. Loosen all Allen head set screws (2) (A) on top of proflo Jr. case and remove magnet housing (C).
2. Remove end plug (D) from end of divider valve where proflo Jr. will be installed. The proflo Jr. may be installed on any convenient divider valve, top to bottom. (Notice: Do not install on any divider valves with cycle indicator pins or any Dropsa divider valve less than SMX16.)
3. Be sure O-ring (F) is in place on magnet housing (C). Screw magnet housing (C) into end of divider valve (E). Torque to 15 foot pounds max.
4. Slide proflo Jr. all the way on magnet housing (C). Torque 15 inch pounds.
5. The LED on the proflo Jr. indicates one complete cycle of the divider block system. Recommended cycle time can be found on a tag on top of the lubricator box or by contacting the compressor manufacturer or the engineer who designed the lube system. If cycle time cannot be identified contact C C Technology at 1-800-664-4033. Correct operation of the proflo Jr. can be verified by the compressor running or by manually pumping oil through the divider valve assembly with a hand purge gun.
6. **NOTE: Due to the design of Lincoln divider blocks it may be necessary to adjust the proflo Jr. by sliding the unit back approximately 1/8" on the magnet assembly until the LED flashes.** All conduit and connections should be appropriate for area classification.
7. After installing the proflo Jr. or performing any maintenance on the lube system, compressor cylinders or packing, it is necessary to purge all air from the divider block lubrication system with a lubrication system purge gun before compressor start-up.

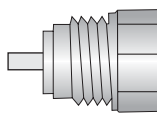


**WARNING: WELDING ON THE COMPRESSOR SKID OR PIPING WITH THE WIRING CONNECTED TO ANYTHING WILL DESTROY THE ALARM CIRCUIT OR CAUSE THE UNIT TO FAIL PREMATURELY AND VOID THE WARRANTY!**

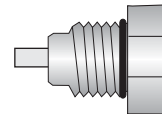
The proflo Jr. must be ordered and installed with the correct magnet assembly for each divider block manufacturer



Alemite, SB & Trabon  
**proflo Jr. Part #0-PF1-JR1-T**

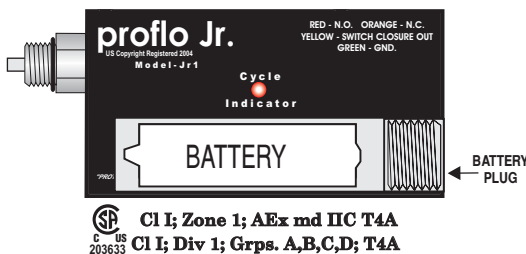


DropsA  
**proflo Jr. Part #0-PF1-JR1-D**



Lincoln  
**proflo Jr. Part #0-PF1-JR1-L**

### Battery Replacement Instructions (TADIRAN 15-5103-41500)



1. Remove Battery Plug using a 3/8" drive ratchet.
2. Remove Battery with needle nose pliers.
3. Remove heat shrink from battery and unsolder wires from battery.
4. Cut leads on new battery to match old battery and solder wires to battery. RED to positive end of battery and BLACK to negative end.
5. Place 3/4" heat shrink 2 1/2" long over battery and wires making sure the heat shrink covers both ends of battery. The heat shrink is necessary to keep the battery from shorting against the inside of the case.
6. Apply heat to the heat shrink and let it cool.
7. Twist the battery as you insert it in the case and replace the battery plug.



**WARNING - EXPLOSION HAZARD - DO NOT DISCONNECT OR CHANGE BATTERIES WHILE CIRCUIT IS LIVE. BATTERIES MUST ONLY BE CHANGED IN A NON-HAZARDOUS AREA.**

**THIS PAGE LEFT INTENTIONALLY BLANK**



# Force Feed Lubricator Pump - Installation & Setup

The Ariel force feed lubricator pump is a fully enclosed, self-lubricating, precision, metering pump capable of pumping small flows of either mineral or synthetic oil to machinery injection points.

## Pressure Relief

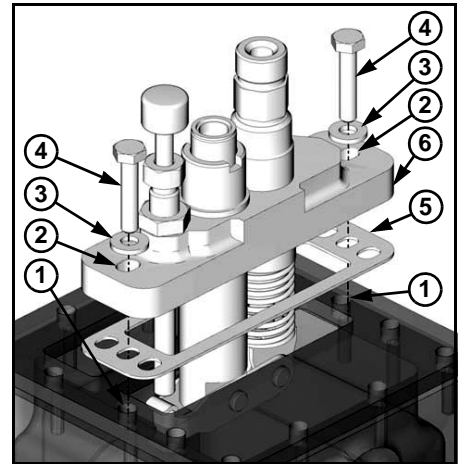
This equipment stays pressurized until pressure is manually relieved. To prevent serious injury from pressurized fluid, such as skin injection, splashing fluid, and moving parts, follow this procedure before cleaning, checking, or servicing the equipment:

1. Stop lubricator pump.
2. If installed, close oil supply valve located upstream from pump. If a supply valve will not close, de-energize and relieve pressure of pressurized oil supplies feeding the pump.
3. Slowly crack open fluid line fittings to relieve pressure.

## Pump Installation


Before installation, verify the lubricator box and lube system are sized appropriately for the selected pressure. Verify a pressure relief device suitable for the application is installed in the system. Refer to Figure 1 during installation.

1. Clean pump body.
2. Remove protective film from gasket (A-18592) and adhere gasket to pump body.
3. Orient pump so the roller bearing on the bottom of the pump aligns with the cam inside the reservoir.
4. Align the pump mounting holes with the reservoir cover mounting holes.
5. Install washers and bolts. Snug the bolts securely, then torque each bolt to 50 in. lbs (5.65 N.m).



- |                                  |                     |
|----------------------------------|---------------------|
| 1. Reservoir Cover Mounting Hole | 3. Washer           |
| 2. Pump Mounting Hole            | 4. Mounting Bolt    |
|                                  | 5. Pump Gasket Hole |
|                                  | 6. Pump Body        |

**FIGURE 1 Pump Installation**

REV	DESCRIPTION	REV	EC	DATE	REV	EC	DATE
							
			0	017848	xx-xx-xx		

## Pump Setup

Before setup, relieve all pressure from the force feed system (see "Pressure Relief").

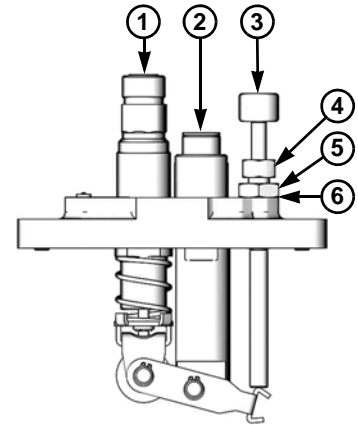
The pump has an internal discharge check valve that opens at 55 psi (3.79 bar). Any oil pressure greater than this cracking pressure allows unrestricted oil flow through the pump, even in a pump at rest or adjusted to zero stroke. Pumps fed 60 psi (4.13 bar) oil from the compressor frame must pass through a 14 psi (0.96 bar) check valve (A-3763) installed at the lube oil gallery connection.

**NOTE: The pump internal discharge check valve has a cracking pressure of 55 psi (3.79 bar).**

### Priming the Pump

Use filtered oil when priming the pump and force feed system (minimum 5 micron nominal filter). Refer to Figure 2 during priming.

1. Remove and discard the plastic plugs in the pump inlet and outlet.
2. Apply thread sealant (user supplied) to inlet and outlet line fittings.
3. Install the inlet and outlet fittings on the pump.
4. Connect the inlet line to the inlet fitting.
5. Introduce oil into the inlet line. If installed, open oil supply valve (located upstream from pump).
6. Remove dirt/debris from pump priming stem and lubricate with oil
7. Manually prime pump by depressing the pump priming stem repeatedly until clean, air-free oil flows from the outlet fitting.
8. Connect outlet line to outlet fitting.
9. Manually prime pump using pump priming stem until clean, air-free oil flows from the outlet line.
10. Connect the outlet line to the lube point.
11. After startup, adjust individual pumps to meet required flow rates. See "Pump Adjustment".



1. Pump Outlet
2. Pump Inlet
3. Pump Priming Stem
4. Flow Adjustment Screw
5. Flow Adjustment Screw Locknut
6. A-9065 O-ring

**FIGURE 2 Pump Priming and Adjustment**

### Pump Adjustment

The flow adjustment screw controls pump flow rate; turning it changes the length of the piston stroke which changes the pump discharge volume. Refer to Figure 2 during adjustment.

1. Loosen the flow adjustment screw locknut.
2. Lubricate the A-9065 o-ring beneath the adjustment screw locknut with oil.
3. Turn the flow adjustment screw. Counterclockwise increases flow and decreases cycle time; clockwise decreases flow and increases cycle time.
4. Check force feed lubricator data plate or Ariel lube sheets for correct cycle time. Adjust flow until desired cycle time is achieved with the force feed system operating.
5. Repeat Steps 2 and 3 as needed.
6. After adjustment to the proper cycle time, tighten the adjustment screw locknut.

**NOTE: Inconsistent flow can occur if pump stroke is set below 20% of maximum stroke.**

**NOTE: A dust seal inside the flow adjustment screw holds the priming stem stationary during operation.**



## Troubleshooting

Relieve all pressure from the system before cleaning, checking, or servicing the equipment.

Pump Problem	Possible Cause	Solution
No flow.	Stroke adjusted to zero.	Adjust pump stroke for desired output. See "Pump Adjustment".
	Plugged pump outlet.	Clean/flush pump outlet.
	Damaged outlet check valve.	Replace pump.
	Damaged or worn inlet check ball and/or seat.	
	Stuck piston.	
	Stuck pump priming stem.	Clean and lubricate the priming stem. Replace pump if priming stem is corroded.
	Insufficient oil supply.	Check for line and filter restrictions upstream of pump. Verify pump inlet is free of debris.
	Air bubbles in the oil.	Prime pump. See "Priming the Pump".
	High oil viscosity.	<ul style="list-style-type: none"> <li>Decrease flow restrictions upstream of pump.</li> <li>Heat oil to maintain viscosity &lt; 1100 cSt. Consult oil supplier for temperature.</li> </ul>
Low flow or erratic operation.	Stroke adjusted to minimal travel.	Adjust pump stroke for desired output. See "Pump Adjustment".
	Damaged or worn inlet check ball and/or seat.	Replace pump.
	Damaged or worn outlet check ball and/or seat.	
	Sticking piston or priming stem.	
	Insufficient oil supply.	Check for line and filter restrictions upstream of pump. Verify pump inlet is free of debris.
	Air bubbles in the oil.	Prime pump. See "Priming the Pump".
	High oil viscosity.	<ul style="list-style-type: none"> <li>Increase flow restrictions upstream of pump.</li> <li>Heat oil to maintain viscosity &lt; 1100 cSt. Consult oil supplier for temperature.</li> </ul>
Low discharge pressure.	Worn piston and bore	Replace pump.
	Damaged or worn inlet check ball and/or seat.	
Fluid flows from pump outlet when not running.	Inlet pressure exceeds cracking pressure of pump outlet check valve.	Reduce inlet pressure to below the cracking pressure. See "Pump Setup".
	Damaged or worn outlet check ball and/or seat.	Replace pump.

## Specifications

- Inlet Size: 1/4" - 18 NPTF
- Outlet Size: 1/8"- 27 NPTF
- Strokes/Minute: Max. - 50; Min. - 3
- Stroke Length: Max. 1/2 inch (12.7 mm)
- Weight: 2.7 lbs (1.22 kg)
- Wetted Parts: carbon steel, stainless steel, aluminum, PTFE, fluoroelastomer
- Max. allowable inlet pressure for priming: 150 PSI (10.34 bar)
- Allowable viscosity range independent of temperature: 80-5000 SUS (16-1100 cSt)

Piston Dia. In. (mm)	Max. Outlet Pressure psi (bar)	Max. Flow <sup>a</sup> In. <sup>3</sup> (cm <sup>3</sup> )
3/16 (4.76)	7500 (517)	0.012 (0.196)
1/4 (6.35)	6000 (414)	0.021 (0.344)
3/8 (9.53)	3500 (241)	0.048 (0.786)

a. Values apply only to a 7/16" stroke length.

**THIS PAGE LEFT INTENTIONALLY BLANK**

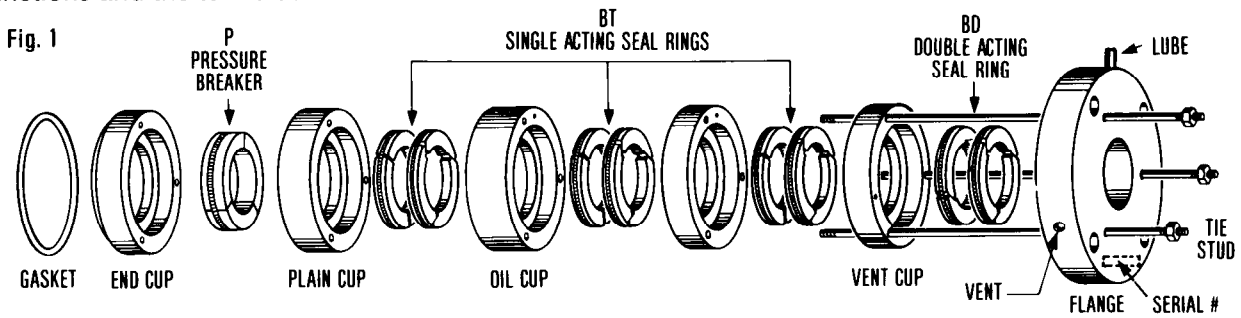
# Installing and Maintaining Cook Rod Rings and Packing Cases

Cook's full floating rod rings are furnished in a variety of designs and materials to suit all operating conditions of reciprocating compressors and engines. It is not the purpose of this pamphlet to cover a particular design, but rather to explain the general characteristics common to most assemblies.

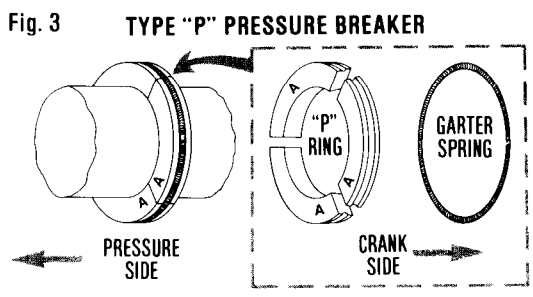
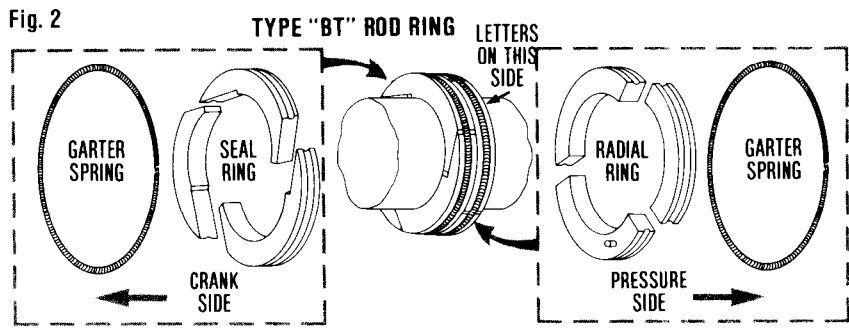
Figure 1 is an exploded view of a typical cup packing case with the various parts in proper order and each part named to familiarize an operator with the functions and the terms used.

Additional rod ring types can be found illustrated in Cook Catalog 785 where proper assembly and position with respect to pressure side is described. Also, refer to Cook Technical Bulletin TPB-76 for more information. It is likely that the exact rod ring, or one very similar to that in which you are interested, will be found among these illustrations.

The packing case comes assembled as it should appear on the rod and carries a six-digit serial number stamped on the face of the flange. When ordering replacement parts, this serial number should be given wherever possible.



Figures 2 and 3 are common type rod rings as they appear on the rod and in their disassembled state.



If installing a new set of rod rings in an existing packing case, the case parts need to be inspected for wear. Cups should be smooth and flat on the back side where the rod rings must seal. If the cups or grooves have worn concave or tapered, they should be reground or relapped. It is rarely necessary to alter the crosshead side of the cups, however, if this is found necessary, care must be taken so that the correct side clearance for the renewal rings is not destroyed. A general guide to the appropriate clearance for rod rings is shown in Table I.

TABLE I

ROD RING SIDE CLEARANCES	
ROD RING MATERIAL	MINIMUM SIDE CLEARANCE PER INCH OF GROOVE WIDTH
Metallic and Carbon	.015"/In
Nonmetallic Except Nylon	.030"/In
Nylon	.045"/In

NOTE: Typical Minimum Side Clearance For Metallic Wiper Rings Is .002"/Ring.



A DOVER RESOURCES COMPANY



## INSTALLATION

In most compressors, it is possible to bolt the packing case into the stuffing box after which the rod can be inserted with the aid of a bullet-nosed sleeve over its threaded end. Before a case is installed, it should always be disassembled and thoroughly cleaned in an appropriate solvent for the intended service.

Make sure that each rod ring and cup is properly positioned and that rings are liberally coated with a clean lubricant before reassembly. Examine all parts for unusual nicks or burrs which might interfere with the free floating of the rod ring in the cups. Particular care should be taken with rod rings made of soft materials such as bronzes or Tfe, and it is extremely important that wiper rings be handled and installed so as to prevent damage to the scraping edges.

Where it is necessary to install the packing case on a piece basis over the rod end, the case parts should be laid out on a work bench so that they can be installed progressively with each in its correct position and the rod rings with their proper faces toward the pressure (Fig. 2 & 3). Note that all rod ring segments are carefully lettered and must be assembled accordingly. This is most important in order to insure proper sealing. After the packing case has been assembled in the stuffing box and its tie studs tightened, the rod should be connected at the cross-head after which the packing case must be carefully aligned with the rod before bolting tightly into position. Alignment is readily accomplished by the use of feelers to maintain a uniform clearance all around between the case bore and the rod.

Connect oil and vent lines as indicated. If a packing case has two or more oil inlets, each

should be connected separately to individual lubricating pump plungers because pressure differentials within the packing body would result in all lubrication going into an outer point. After all connections are made, the packing case should be flooded by hand operation of the lubricating plungers to make sure lines are not air bound.

This same operation should be repeated each time a compressor is started because oil lines may have been bled during down time.

For new installations, care must be given to the cleaning of all accumulated dirt in the lines and compressors because foreign material will lodge in the packing to become destructively abrasive.

Prior to installing the packing case into the stuffing box, the end cup gasket must be inspected for nicks and damage that would cause it to leak in service. When in doubt, replace the gasket with a new one.

## LUBRICATION

All lube oil lines should be fitted with a check valve at the case inlet. The selection of a proper lubricant will depend on the service involved and a Cook field service engineer should be contacted before proceeding, especially on high-pressure work or whenever there are elements in the gas which might be destructive to ordinary lubrication.

Oil ratings will range from SAE 30 for low pressure work to SAE 60 and higher for extremely high pressure. Special inhibitors or compounded oils should be used only where necessary because of unusual conditions or as recommended by a service engineer.

During initial operation, a packing case may leak or tend to overheat. This is temporary while the rings are properly mating to the rod and case. It is advisable to break in the rings on a gradually increasing pressure scale. The amount of time required will depend on the condition involved. Additional information on break-in procedures is available in Cook Bulletin TBP-76.

## VENT CONNECTIONS

Most packing cases are equipped with a vent for safety reasons. This is usually connected by a separate line to atmosphere or to some point in the system where the back pressure does not exceed 15 psi.

In all back pressure vents, a check valve should be provided so that there is no flow from the vent line to the packing case. If the vent back pressure will exceed 35 pounds, a Cook service engineer should be contacted for ring and case design recommendations.

## STATIC-PAC™

When a packing case is being assembled which incorporates a Static-Pac™, the lip seal and all associated springs and O-rings must be inspected for possible damage. Cases utilizing a Static-Pac™ normally require that all cup faces be coated with a light film of sealant, such as Never-Seez, to prevent case leakage. Additional information on the operation of the Static-Pac™ is available in Catalog 785 and Bulletin 784.

**C. Lee Cook**

A DOVER RESOURCES COMPANY

Printed in U.S.A.

# Force Feed Lubricator Pump - Installation & Setup

The Ariel force feed lubricator pump is a fully enclosed, self-lubricating, precision, metering pump capable of pumping small flows of either mineral or synthetic oil to machinery injection points.

## Pressure Relief

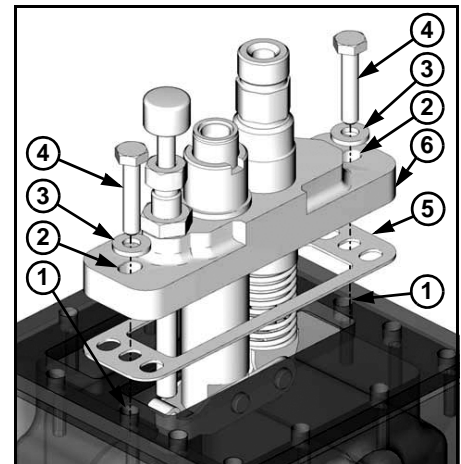
This equipment stays pressurized until pressure is manually relieved. To prevent serious injury from pressurized fluid, such as skin injection, splashing fluid, and moving parts, follow this procedure before cleaning, checking, or servicing the equipment:

1. Stop lubricator pump.
2. If installed, close oil supply valve located upstream from pump. If a supply valve will not close, de-energize and relieve pressure of pressurized oil supplies feeding the pump.
3. Slowly crack open fluid line fittings to relieve pressure.

## Pump Installation

Before installation, verify the lubricator box and lube system are sized appropriately for the selected pressure. Verify a pressure relief device suitable for the application is installed in the system. Refer to Figure 1 during installation.

1. Clean pump body.
2. Remove protective film from gasket (A-18592) and adhere gasket to pump body.
3. Orient pump so the roller bearing on the bottom of the pump aligns with the cam inside the reservoir.
4. Align the pump mounting holes with the reservoir cover mounting holes.
5. Install washers and bolts. Snug the bolts securely, then torque each bolt to 50 in. lbs (5.65 N.m).



- |                                  |                     |
|----------------------------------|---------------------|
| 1. Reservoir Cover Mounting Hole | 3. Washer           |
| 2. Pump Mounting Hole            | 4. Mounting Bolt    |
|                                  | 5. Pump Gasket Hole |
|                                  | 6. Pump Body        |

**FIGURE 1 Pump Installation**

REV	DESCRIPTION	REV	EC	DATE	REV	EC	DATE
	0		017848	xx-xx-xx			

## Pump Setup

Before setup, relieve all pressure from the force feed system (see "Pressure Relief").

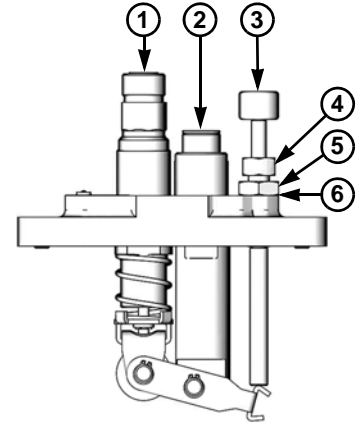
The pump has an internal discharge check valve that opens at 55 psi (3.79 bar). Any oil pressure greater than this cracking pressure allows unrestricted oil flow through the pump, even in a pump at rest or adjusted to zero stroke. Pumps fed 60 psi (4.13 bar) oil from the compressor frame must pass through a 14 psi (0.96 bar) check valve (A-3763) installed at the lube oil gallery connection.

**NOTE: The pump internal discharge check valve has a cracking pressure of 55 psi (3.79 bar).**

### Priming the Pump

Use filtered oil when priming the pump and force feed system (minimum 5 micron nominal filter). Refer to Figure 2 during priming.

1. Remove and discard the plastic plugs in the pump inlet and outlet.
2. Apply thread sealant (user supplied) to inlet and outlet line fittings.
3. Install the inlet and outlet fittings on the pump.
4. Connect the inlet line to the inlet fitting.
5. Introduce oil into the inlet line. If installed, open oil supply valve (located upstream from pump).
6. Remove dirt/debris from pump priming stem and lubricate with oil
7. Manually prime pump by depressing the pump priming stem repeatedly until clean, air-free oil flows from the outlet fitting.
8. Connect outlet line to outlet fitting.
9. Manually prime pump using pump priming stem until clean, air-free oil flows from the outlet line.
10. Connect the outlet line to the lube point.
11. After startup, adjust individual pumps to meet required flow rates. See "Pump Adjustment".



1. Pump Outlet
2. Pump Inlet
3. Pump Priming Stem
4. Flow Adjustment Screw
5. Flow Adjustment Screw Locknut
6. A-9065 O-ring

**FIGURE 2 Pump Priming and Adjustment**

### Pump Adjustment

The flow adjustment screw controls pump flow rate; turning it changes the length of the piston stroke which changes the pump discharge volume. Refer to Figure 2 during adjustment.

1. Loosen the flow adjustment screw locknut.
2. Lubricate the A-9065 o-ring beneath the adjustment screw locknut with oil.
3. Turn the flow adjustment screw. Counterclockwise increases flow and decreases cycle time; clockwise decreases flow and increases cycle time.
4. Check force feed lubricator data plate or Ariel lube sheets for correct cycle time. Adjust flow until desired cycle time is achieved with the force feed system operating.
5. Repeat Steps 2 and 3 as needed.
6. After adjustment to the proper cycle time, tighten the adjustment screw locknut.

**NOTE: Inconsistent flow can occur if pump stroke is set below 20% of maximum stroke.**

**NOTE: A dust seal inside the flow adjustment screw holds the priming stem stationary during operation.**



## Troubleshooting

Relieve all pressure from the system before cleaning, checking, or servicing the equipment.

Pump Problem	Possible Cause	Solution
No flow.	Stroke adjusted to zero.	Adjust pump stroke for desired output. See "Pump Adjustment".
	Plugged pump outlet.	Clean/flush pump outlet.
	Damaged outlet check valve.	Replace pump.
	Damaged or worn inlet check ball and/or seat.	
	Stuck piston.	
	Stuck pump priming stem.	Clean and lubricate the priming stem. Replace pump if priming stem is corroded.
	Insufficient oil supply.	Check for line and filter restrictions upstream of pump. Verify pump inlet is free of debris.
	Air bubbles in the oil.	Prime pump. See "Priming the Pump".
	High oil viscosity.	<ul style="list-style-type: none"> <li>Decrease flow restrictions upstream of pump.</li> <li>Heat oil to maintain viscosity &lt; 1100 cSt. Consult oil supplier for temperature.</li> </ul>
Low flow or erratic operation.	Stroke adjusted to minimal travel.	Adjust pump stroke for desired output. See "Pump Adjustment".
	Damaged or worn inlet check ball and/or seat.	Replace pump.
	Damaged or worn outlet check ball and/or seat.	
	Sticking piston or priming stem.	
	Insufficient oil supply.	Check for line and filter restrictions upstream of pump. Verify pump inlet is free of debris.
	Air bubbles in the oil.	Prime pump. See "Priming the Pump".
	High oil viscosity.	<ul style="list-style-type: none"> <li>Increase flow restrictions upstream of pump.</li> <li>Heat oil to maintain viscosity &lt; 1100 cSt. Consult oil supplier for temperature.</li> </ul>
Low discharge pressure.	Worn piston and bore	Replace pump.
	Damaged or worn inlet check ball and/or seat.	
Fluid flows from pump outlet when not running.	Inlet pressure exceeds cracking pressure of pump outlet check valve.	Reduce inlet pressure to below the cracking pressure. See "Pump Setup".
	Damaged or worn outlet check ball and/or seat.	Replace pump.

## Specifications

- Inlet Size: 1/4" - 18 NPTF
- Outlet Size: 1/8"- 27 NPTF
- Strokes/Minute: Max. - 50; Min. - 3
- Stroke Length: Max. 1/2 inch (12.7 mm)
- Weight: 2.7 lbs (1.22 kg)
- Wetted Parts: carbon steel, stainless steel, aluminum, PTFE, fluoroelastomer
- Max. allowable inlet pressure for priming: 150 PSI (10.34 bar)
- Allowable viscosity range independent of temperature: 80-5000 SUS (16-1100 cSt)

Piston Dia. In. (mm)	Max. Outlet Pressure psi (bar)	Max. Flow <sup>a</sup> In. <sup>3</sup> (cm <sup>3</sup> )
3/16 (4.76)	7500 (517)	0.012 (0.196)
1/4 (6.35)	6000 (414)	0.021 (0.344)
3/8 (9.53)	3500 (241)	0.048 (0.786)

a. Values apply only to a 7/16" stroke length.

**THIS PAGE LEFT INTENTIONALLY BLANK**